

Version
January 2012

Program

SHAPE 7

**Cross-Section Characteristics and
Design of Thin-Walled Sections**

Program Description

All rights, including those of the translation, are reserved.

No portion of this book may be reproduced – mechanically,
electronically, or by any other means, including photocopying –
without written permission of ING. SOFTWARE DLUBAL.

© Ing. Software Dlubal
Am Zellweg 2 D-93464 Tiefenbach

Tel.: +49 (0) 9673 9203-0
Fax: +49 (0) 9673 9203-51
E-mail: info@dlubal.com
Web: www.dlubal.com

Contents

Contents		Page	Contents		Page
1.	Introduction	6	4.3.1	Menu Bar	36
1.1	New in SHAPE 7	6	4.3.2	Toolbars	36
1.2	Company Profile	7	4.3.3	Navigator	38
1.3	The SHAPE Team	7	4.3.4	Tables	39
1.4	Using the Manual	8	4.3.5	Status Bar	39
2.	Install SHAPE	9	4.3.6	Control Panel	40
2.1	System Requirements	9	4.3.7	Default Buttons	43
2.2	Installation	9	4.3.8	Keyboard Functions	44
2.2.1	Installation from DVD	9	4.3.9	Context Menus	45
2.2.2	Network Installation	10	4.4	File Management	46
2.2.3	Updates	10	4.4.1	Project Manager	46
2.2.4	Installation of SHAPE 5/6 and SHAPE 7	10	4.4.1.1	Projects	48
3.	Introductory Example	11	4.4.1.2	Sections	50
3.1	Cross-Section and Internal Forces	11	4.4.1.3	Data Archiving	52
3.2	Start SHAPE and Create Section	12	4.4.1.4	Appearance	53
3.3	Section Data	12	4.4.2	Create New Section	53
3.3.1	Work Window and Grid	12	4.4.2.1	General Data	54
3.3.2	Set Elements	13	4.4.2.2	Details	56
3.3.3	Edit Elements	14	4.4.2.3	Plastic Design	59
3.3.4	Set Section	15	4.4.2.4	c/t Zones	60
3.3.5	Mirror Elements	17	4.4.2.5	Effective Cross-Sections	61
3.3.6	Set and Delete Point Elements	18	4.4.3	Network Management	63
3.3.7	Insert Opening	20	5.	Section Data	64
3.3.8	Plausibility Check and Save	20	5.1	Nodes	66
3.3.9	Check Input Tables	21	5.2	Materials	68
3.3.10	Edit Material	22	5.3	Sections	73
3.3.11	Define Internal Forces	23	5.4	Elements	76
3.4	Calculation	24	5.5	Point Elements	79
3.5	Results	24	5.6	c/t Zones	82
3.5.1	Select Results	25	5.7	Forces and Moments	84
3.5.2	Arrange Results Windows	27	6.	Calculation	90
3.5.3	Printout Report	28	6.1	Plausibility Check	90
3.6	Outlook	31	6.2	Crossing Elements	90
4.	User Interface	32	6.3	Interconnecting Elements	91
4.1	Overview	32	6.4	Plastic Calculation	91
4.2	Terminology	32	6.5	Start Calculation	92
4.3	SHAPE User Interface	36	7.	Results	93

Contents

Contents		Page	Contents		Page
7.1	Section Properties	93	9.2.2	Print Quality	165
7.2	Statical Moments	104	9.2.3	Color Spectrum	166
7.3	Normal Stresses σ_x	107	10.	Tools	167
7.4	Shear Stresses τ	110	10.1	Edit Objects	167
7.5	Equivalent Stresses σ_{eqv}	114	10.1.1	Graphic Selection	167
7.6	Plastic Capacity	116	10.1.2	Special Selection	167
7.7	Check of c/t Zones	120	10.1.3	Move and Copy	168
7.8	Shear Wall Section Properties	122	10.1.4	Rotate	169
7.9	Shear Forces	124	10.1.5	Mirror	169
7.10	Classification	127	10.1.6	Divide	170
7.11	Effective Widths	131	10.1.7	Insert Opening	171
7.11.1	DIN 18800	131	10.1.8	Create and Reduce Section	171
7.11.2	EN 1993-1	134	10.1.9	Scale Elements	173
8.	Results Evaluation	138	10.2	CAD Tools	174
8.1	Results Selection	138	10.2.1	Grid	174
8.2	Results Display	139	10.2.2	Smoothen Corners	175
8.3	Results Values	141	10.2.3	Round off Corners	175
8.4	Multiple Windows View	142	10.2.4	Connect Elements	176
8.5	Filter Results	143	10.2.5	Connect Node and Element	177
9.	Printout	146	10.2.6	Extend Element to Element	177
9.1	Printout Report	146	10.2.7	Change Element Length	178
9.1.1	Create or Open Printout Report	146	10.2.8	Set Parallel Elements	179
9.1.2	Work in Printout Report	147	10.2.9	Create Rectangular Hollow Section	179
9.1.3	Define Contents of Printout Report	149	10.2.10	Create Circular Hollow Section	180
9.1.3.1	Select Section Data	150	10.3	Table Functions	181
9.1.3.2	Select Load Data	150	10.3.1	Editing Functions	181
9.1.3.3	Select Results	151	10.3.2	Block Functions	183
9.1.4	Adjust Printout Report Header	152	10.3.3	Viewing Functions	186
9.1.5	Insert Section Images	154	10.3.4	Table Settings	187
9.1.6	Insert Graphics and Texts	155	10.3.5	Filter Functions	188
9.1.7	Printout Report Template	157	10.3.6	Import and Export Tables	188
9.1.8	Adjust Layout	158	10.4	General Functions	191
9.1.9	Print Printout Report	158	10.4.1	Display Objects	191
9.1.10	Export Printout Report	159	10.4.2	Viewing Options	192
9.1.11	Language Settings	160	10.4.3	Units and Decimal Places	193
9.2	Direct Graphic Printout	161	10.4.4	Dimensions	194
9.2.1	Image	161	10.4.5	Comments	195

Contents

Contents		Page	Contents		Page
10.4.6	Measure Function	196	A	Literature	201
10.4.7	Find Objects	196	B	Index	202
11.	Interfaces	197			
11.1	DLUBAL ASCII Files *.inp / *.aus	198			
11.2	ASCII Files *.dxf	198			

1. Introduction

1.1 New in SHAPE 7

SHAPE-THIN is a professional, user-friendly program for the analysis and design of thin-walled cross-sections. The stand-alone module is based on the effective program concept of the RSTAB and RFEM software family. For example, the user is able to exchange different sectional elements between individual SHAPE files with drag & drop. At the same time, the internal forces and moments of member elements can be taken from any RSTAB or RFEM structure. It is also possible to directly export the section properties to MS Excel™ for additional editing.

SHAPE-THIN characteristics include:

- Interactive input in graphics and tables
- Access to cross-sections of the extensive DLUBAL sections' library
- CAD-like modeling due to comfortable construction tools
- Editing tools: Smoothen or round out corners, connect elements, insert openings etc.
- Generation of circular or rectangular hollow sections
- Determination of section properties for general open and closed cross-sections
- Plastic section characteristics due to non-combined loading
- Design of normal, shear and equivalent stresses and comparison with limit stresses
- Import of load cases and internal forces of members from RSTAB and RFEM
- Export of the section properties to RSTAB/RFEM and design modules
- Consideration of different materials in the cross-section
- Section characteristics of reinforced skyscraper cores and forces in the individual walls
- Project Manager for overall data management of SHAPE-THIN sections
- Printout report with individual contents and layout

Essential innovations in SHAPE 7 are:

- Precise modeling of section geometry via arcs and point elements
- DXF import of contours or center lines to facilitate the modeling
- Dummy elements with user-definable effective thickness for shear
- Plastic load capacity based on Simplex algorithm for general line-up of internal forces
- User-definable c/t zones and check of maximum c/t ratios according to DIN 18 800
- Colored results distribution on cross-section with adaptable color spectrum
- Display of section contour and inertia ellipse
- User-definable icons and selection in the results tables
- Option to display distribution of results in sheet plane
- Filtering of stresses for extreme results of all x-locations
- Determination of J according to St. Venant or FEA
- Analysis of the effective cross-sections according to DIN 18 800, EN 1993-1-1 and EN 1993-1-5 or EN 1999-1-1
- Extended material and cross-section libraries
- Integral of shear forces due to shear stresses for each element
- User-definable factor for τ in order to determine equivalent stresses

We wish you much success using SHAPE-THIN. Your comments resulting from the everyday use of DLUBAL applications are welcome for the ongoing development of the program.

DLUBAL ENGINEERING SOFTWARE

1.2 Company Profile

Since its beginnings in 1987, ING. SOFTWARE DLUBAL has been involved in the development of user-friendly and powerful programs for structural analyses. In 1990, ING. SOFTWARE DLUBAL moved into its current location to Tiefenbach in Eastern Bavaria.

Looking at our programs, you can feel the enthusiasm of everybody involved in the development and you will notice the underlying philosophy of all our applications, which can be subsumed in the word 'user-friendliness'. These two points combined with the professional competence build the base for the ever-growing success of our products.

The software is designed to allow even users with basic computer skills to handle the software successfully after a short while. With considerable pride, we now count more than 7,000 engineering offices, construction companies from a variety of fields and places of higher education to our list of satisfied customers around the world. To remain true to our objectives, there are more than 100 internal and external employees working continuously to improve and develop the DLUBAL applications. For general questions and problems, you can always rely on our qualified and free hotline.

The perfect balance between price and performance combined with the excellent customer service make DLUBAL programs an essential tool for anyone involved in the areas of statics, dynamics and design.

1.3 The SHAPE Team

The following people were involved in the development of SHAPE 7:

Program Coordination:

Dipl.-Ing. Georg Dlubal
 Ing. Jan Rybín, Ph.D.

Dipl.-Ing. (FH) Robert Vogl

Programming:

RNDr. Vladimír Ulrich
 Dipl.-Ing. Georg Dlubal

Mgr. Petr Oulehle

Program Design, Dialog Boxes and Icons

Dipl.-Ing. Georg Dlubal
 MgA. Robert Kolouch

Zdeněk Ballák
 Ing. Jan Milář

Program Supervision:

Ing. Jan Rybín, Ph.D.
 Ing. Martin Hlavačka

Ing. František Knobloch

Manual, Help System and Translations

Dipl.-Ing. (FH) Robert Vogl
 Ing. Jan Rybín, Ph.D.

Mgr. Petra Pokorná
 Jan Jeřábek

Technical Support and Program Testing

Dipl.-Ing. (FH) Matthias Entenmann
 Dipl.-Ing. Frank Faulstich
 Dipl.-Ing. (FH) René Flori
 Dipl.-Ing. (FH) Bastian Kuhn
 M. Sc. Dipl.-Ing. Frank Lobisch

Dipl.-Ing. (BA) Andreas Niemeier
 Dipl.-Ing. (FH) Walter Rustler
 M. Sc. Dipl.-Ing. (FH) Frank Sonntag
 Dipl.-Ing. (FH) Christian Stautner
 Dipl.-Ing. (FH) Robert Vogl

1.4 Using the Manual



To facilitate the reading of this manual, the term "SHAPE" will be used instead of the full name of the "SHAPE-THIN" program.

Many ways lead to Rome – this also applies to working with SHAPE: Graphics, tables and the data navigator are on an equal footing here. To maintain the character of a reference book, the manual follows the order and the structure of the tables for the input and results data. The individual tables are described in detail column by column. Instead of presenting general Windows features, the manual rather gives practical hints and notes.

If you are new to the SHAPE cross-section software, you should work through the introductory example in chapter 3. Thereby, you will get familiar with the most important features of the program.

The text of the manual shows the described buttons in square brackets, e.g. [OK]. Additionally, the expressions of the dialog boxes, tables and menus are set in *italics* to clarify the explanations.

Another feature of this manual is its **index** which is very useful if you are looking for particular expressions. You can also check our website at www.dlubal.com where you can go through our FAQ pages.

2. Install SHAPE

2.1 System Requirements

To use SHAPE 7 comfortably, we recommend the following minimum system requirements:

- Operating system Windows XP/Vista/7
- X86-CPU with 1 GHz
- 512 MB RAM
- DVD-ROM drive for installation, alternatively installation via network
- 10 GB hard disk capacity, around 80 MB for installation
- Graphics card with a resolution of 1024 x 768 pixels



SHAPE 7 does not run under Windows 95/98/Me/NT.

With the exception of the operating system, no product recommendations are made, as SHAPE basically runs on all systems that fulfill the system requirements.

SHAPE benefits only very little from SMT systems. Because SHAPE is a 32 bit program, it does not use 64 bit extensions like EM64T or AMD64 or the features of Windows 7 64 bit.

2.2 Installation



SHAPE is delivered on the Dlubal Applications DVD. This DVD contains the main programs RFEM and RSTAB with all add-on modules and also the stand-alone module SHAPE 7.

To run the program as a full version, you need the corresponding hardlock and an authorization file. Your authorization file contains coded data for your authorization. Attach the hardlock to your printer port or USB connector. The printer cable can then be connected to the hardlock. The performance of the printer will not be influenced by the hardlock.

You need the authorization file for each work station. The authorization file can be copied as many times as required. However, if the content is changed in any way, it cannot be used for authorization any longer. In case you later receive a new DVD as an update, you normally can use again the existing authorization file. However, when you have purchased an additional program module, you will receive a new authorization file. Then the old one must not be used.

Before you install SHAPE, close all other programs and install the hardlock on a printer port, resp. the USB hardlock to a USB port of your computer.

For the installation, you have to be registered as administrator resp. have administrator rights. When working with SHAPE, user rights will be sufficient.

2.2.1 Installation from DVD

First, read the instruction guide on the back of the DVD cover. There you will find information on how to install the software.

- Insert the DVD into your DVD-ROM drive.
- The installation process will start automatically.
- Select the language in the opening screen.
- Click [Install RSTAB].
- Follow the instructions of the setup wizard.

If the installation does not start automatically, autoplay is disabled on your DVD-ROM drive. In this case, click the icon [My computer] with the left mouse button, then the symbol of your DVD-ROM drive with the DLUBAL logo. In this folder of the DVD-ROM, you have to double-click the file **setup.exe**.

The DVD also contains the manual as PDF document. For this, you need the Acrobat Reader that can be installed from the installation menu with [Install Acrobat Reader]. By clicking [SHAPE Manual], the Acrobat Reader will open the manual. Afterwards you can view and print the document.

There are also several video clips on the DVD to make the first steps easier. To play these, you will need the Windows Media Player or the Real Player.

The button [Software Information] opens a PDF document with information on the currently available programs of DLUBAL ENGINEERING SOFTWARE.

2.2.2 Network Installation

The installation can be started from any drive of the computer or of a server. Copy the contents of the DVD and - if needed - the authorization file simply to a specific folder. Then start the file **setup.exe** from a client. The following steps are no different than the installation directly from the DVD.

2.2.3 Updates

As mentioned before, the DVD contains the complete program package. When as part of a service delivery you need to install a new RSTAB or RFEM DVD, make sure that you always use the up-to-date authorization file.



In case you work with user-defined printout report headers, you better save these before installing an update. These headers are stored in the file **DlubalProtocolConfig.cfg** in the master data folder (by default C:\Program Files\Dlubal\Stammdat). This folder is write-protected, even though a backup copy is advisable here.

If you use the sample print reports, you should save the file **DuenqProtocolConfig.cfg** before installing an update. This file is located in the Dlubal master data folder, too.

The projects in the project manager are managed in the ASCII-type **DU_PRO.DLP** file that is located in the Dlubal master data folder (..\Dlubal\Stammdat), too. If you want to uninstall SHAPE 7 completely before a reinstallation, you should save also this file.

2.2.4 Installation of SHAPE 5/6 and SHAPE 7

All Dlubal applications SHAPE 5, SHAPE 6 and SHAPE 7 can be run parallel on one computer, as the program files are contained in different folders. The default folders are

- SHAPE 5: C:\Program Files\Dlubal\DUENQ,
- SHAPE 6: C:\Program Files\Dlubal\DUENQ6,
- SHAPE 7: C:\Program Files\Dlubal\DUENQ7.

All cross-sections created with the previous versions of SHAPE can be opened and edited in SHAPE 7. The files are upwards compatible without any problem. Sections created with SHAPE 7 can e.g. also be opened in SHAPE 6 but specific features of the newer version will not be available there, such as arcs or effective cross-section data. Make sure not to overwrite sections by accident when opening them in previous versions as the data format is identical.

When installing SHAPE 7, the Project Manager is updated automatically so that your existing cross-sections will be available without further settings.

3. Introductory Example

This chapter helps you to become familiar with the most important functions of SHAPE using a simple example. Because there are many ways how to do things according to the situation and preferences of the user, it might make sense to use one or the other way. This example wants you to discover the possibilities and options of SHAPE on your own.

3.1 Cross-Section and Internal Forces

In our example *SHAPE*, a welded steel angle is connected to an unequal rolled angle section L 200x100x14. Additionally, a bolt hole is punched in the top flange.

The section properties and stresses are to be determined for the following cross-section.

Cross-Section

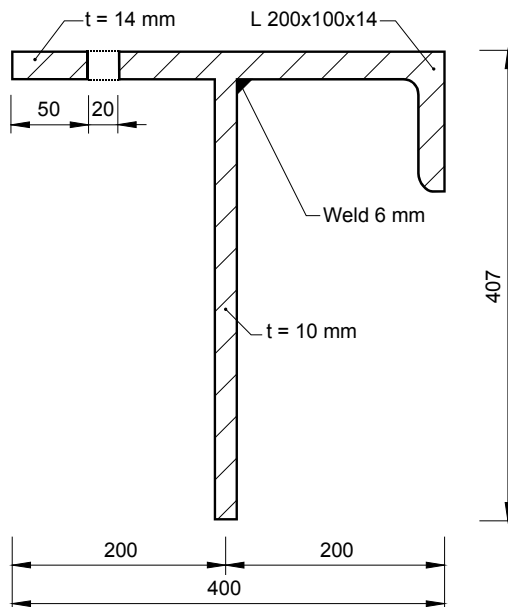

Figure 3.1: Sketch of the *SHAPE* cross-section

Material

Steel Grade S 235 JR

Internal Forces

The internal forces of two different load cases are to be analyzed. The shear forces and bending moments are related to the principal axes u and v of the cross-section.

Internal Force	LC 1	LC 2
N [kN]	80.0	-30.0
V_u [kN]	25.0	-25.0
V_v [kN]	95.0	95.0
M_u [kNm]	50.0	50.0
M_v [kNm]	10.0	-10.0

Table 3.1: Internal forces

3.2 Start SHAPE and Create Section

You can start SHAPE via

Start → **Programs** → **Dlubal** → **Dlubal SHAPE-THIN 7.xx**

or the icon **Dlubal SHAPE-THIN 7.xx** on your desktop.

When SHAPE is started, a dialog box in the main window appears and asks you to enter the general data for the new section. If a section has already been entered, close this opened file by clicking on the [X] in the toolbar or via menu **File** → **Close**. Then select **File** → **New** so that the following dialog box is shown.

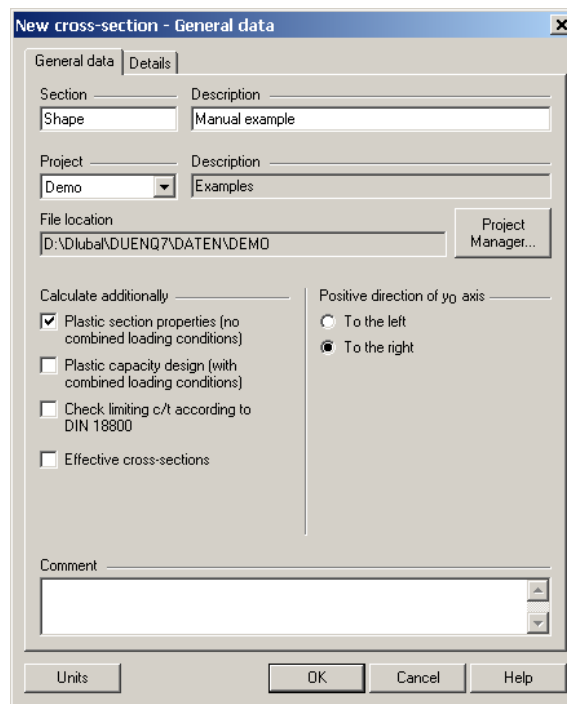

Figure 3.2: Dialog box *New Cross-Section - General Data*

Type **Shape** in the input field *Section* and **Manual example** in the *Description* field as shown above. The *Section* must always be filled in because this entry will be used as file name. The *Description* does not necessarily need to be filled in.

In the input box *Project*, select the project **Demo** from the list, if not already set by default. The *Description* of the project and the specific *File Location* will be displayed automatically.

Adopt the remaining settings of this dialog box without changes. You can enter some additional explanation in the *Comments* field.

When you close this dialog box with [OK], an empty work area will be displayed.

3.3 Section Data

3.3.1 Work Window and Grid



First, maximize the work window with the button in the title bar. The directions of the axes y_0 and z_0 are visible on the screen.



The position of the axis system can be adjusted on the screen. For this, select [Move] from the toolbar. The mouse pointer changes into a hand. You can now position the work area according to your wishes with the pressed left mouse button.

In the same way you can also zoom in a section by pulling with the pressed [Ctrl] or [Shift] key. Alternatively, you can use the mouse wheel.

The work area has a grid as background. You can set the spacing of the grid points in the dialog box *Grid settings*.

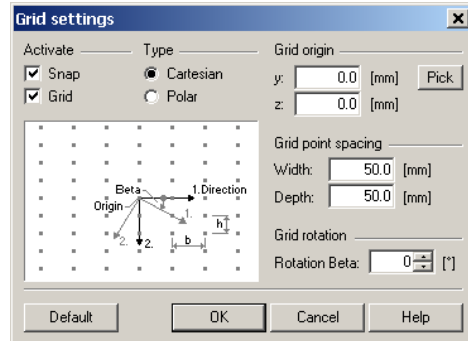

Figure 3.3: Dialog box *Grid settings*



You can access this dialog box with the button [Set grid] in the toolbar.

The default settings are suitable for our example so that we can close this dialog box with [OK] to start the input of the section.

3.3.2 Set Elements

It would be possible to individually define the corner nodes either in the graphics or in the table first and to connect them by elements later. It is faster, however, to enter the elements directly in the graphics. The corresponding nodes will be created automatically.



Call up menu **Insert** → **Elements** → **Graphics** → **Polygonwise** or the corresponding button in the toolbar. The dialog box *New Element* appears.

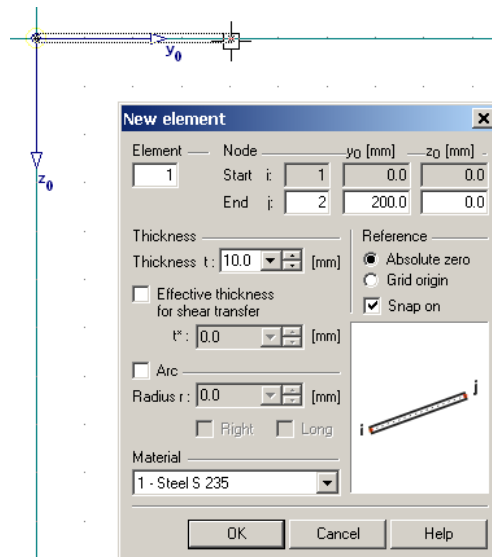

Figure 3.4: Dialog box *New element*

The *Element* and *Node* are already set at 1. As the node coordinates are applied on the **Absolute Zero** of the coordinate system, accept this default setting as well as the element *Thickness* of 10.0 mm which we will modify later. **Steel S 235** has been preset as *Material*. We accept also this default setting as the steel grade is to be changed subsequently, too.

If you move the mouse over the graphical work area now, you will see the coordinates of the pointer position change in the defined grid spacing of 50 mm.

Node number 1 is set as *Start Node* by clicking with the left mouse button exactly on the origin. The *End Node* 2 of the element is set on the $y' = 200.0 \text{ mm}$, $z' = 0.0 \text{ mm}$ location.

Because we selected the *Polygonwise* option, node 2 now represents the start node of the next element number 2. So, we can now set node 3 on the $y' = 200.0 \text{ mm}$, $z' = 400.0 \text{ mm}$ location.



The command is ended by clicking with the right mouse button or pressing [Esc]. The dialog box closed in the same manner. Fill the main window with the two elements using the **View** → **Show All** menu or pressing the [F8] key or the corresponding button seen to the left.

For the further input, we recommend you to show the numbering of nodes and elements. Do this through the context menu, reached by right-mouse clicking on an empty area of the graphics. In the context menu, click the *Numbering* option with the left mouse button.

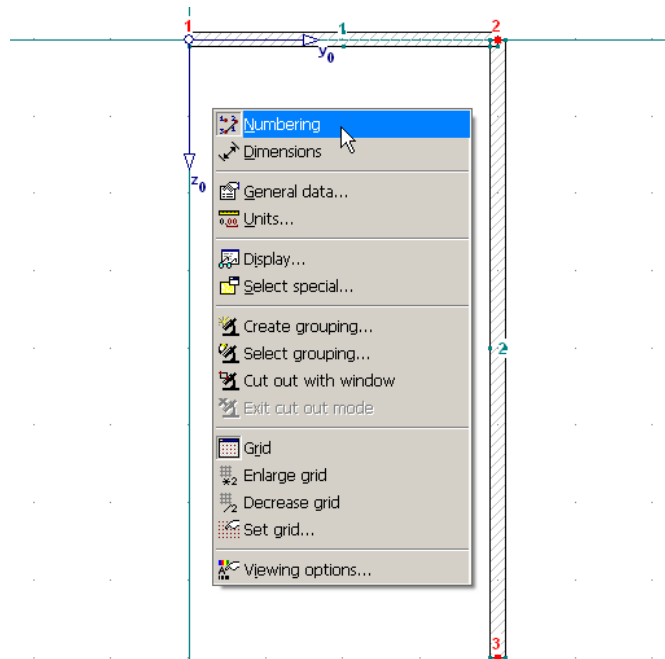

Figure 3.5: Context menu: *Numbering*

3.3.3 Edit Elements

If you move the mouse pointer over element 1 and hold it there, SHAPE shows further information on the element, including its thickness t of 10.0 mm.

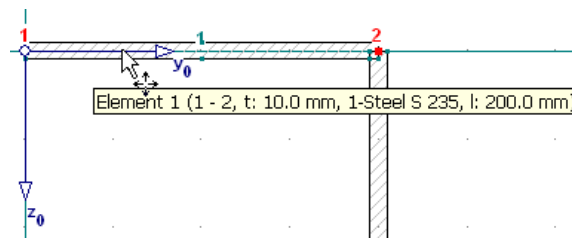

Figure 3.6: Element info

Because the element is 14.0 mm thick in reality, a correction is necessary. Double-click the element 1 to open the *Edit Element* dialog box. There, click in the *Thickness t* input field. Type in 14.0 for the correct thickness and confirm it by clicking on the [OK] button.

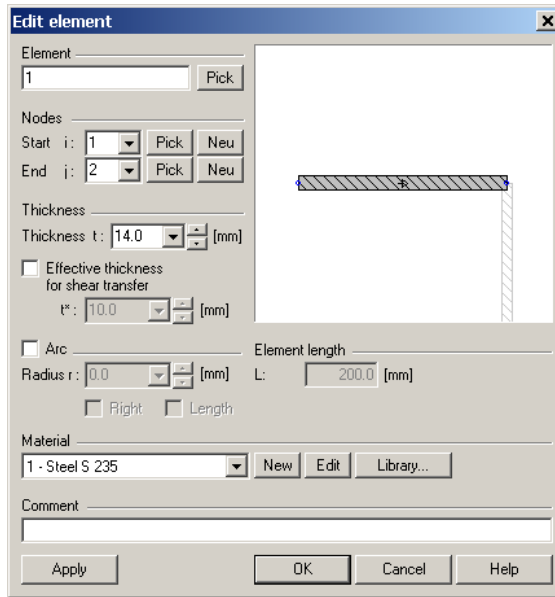

Figure 3.7: Dialog box *Edit element*

The section will be updated in the graphics and also in table 1.4 *Elements*.

3.3.4 Set Section



The next step is to add the unequal angle cross-section 200 x 100 x 14 from the sections' library to element 1. Choose the **Insert** → **Sections** → **Graphics** → **Section library** menu or click the corresponding button in the toolbar as seen on the left to call up the library.

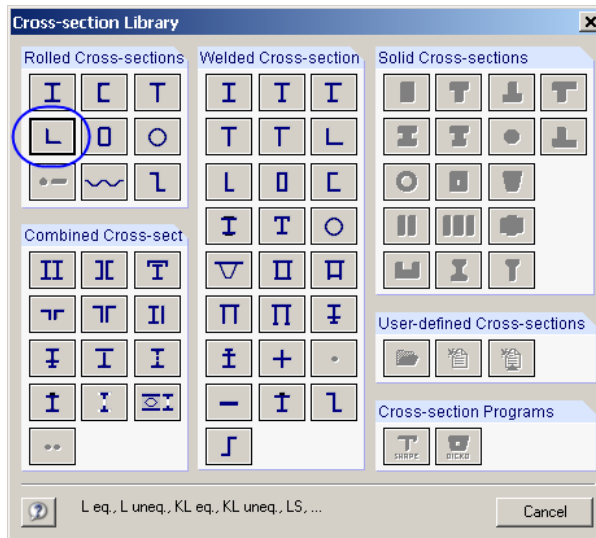

Figure 3.8: Cross-section library

Click the L-shape button (*Rolled Cross-Sections*, 2nd row, left) to open the entire table of L-shaped rolled sections. In the *Table* list, select **L Unequal Legs, Preferred** and then scroll down the *Cross-Section* list to the end to select **L 200x100x14**. Finally, confirm with [OK].

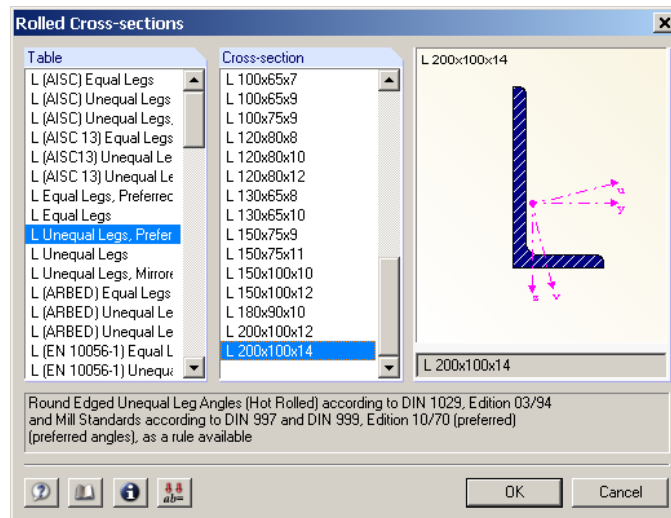

Figure 3.9: Rolled angle sections L

The dialog box *Set Section* opens. The dotted L section can be moved over the work area with the mouse. Enter the *Section Rotation* $\beta = -90^\circ$ using the small spin button next to the input field or typing in the value.

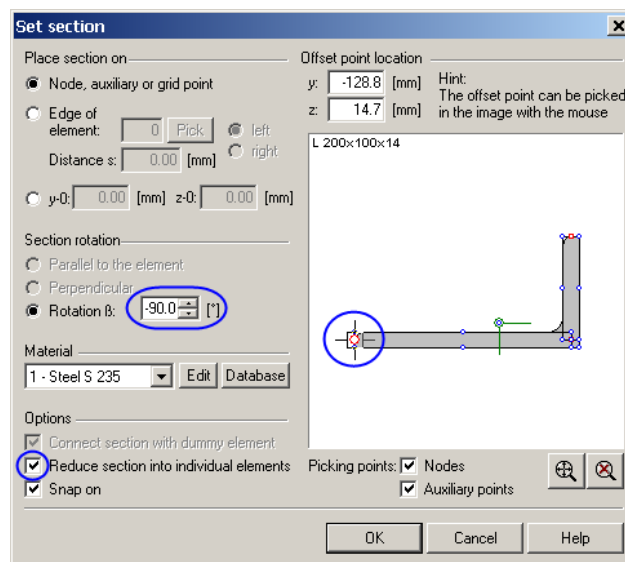

Figure 3.10: Dialog box *Set section*: Rotation and offset point

The current *Offset Point* to set the section lies in the center of gravity. It is marked with a slightly larger red circle in the image of this dialog box. Because we want to connect the section with its longer leg, we select a new, more favorable offset point by picking it in the image. Move the pointer (now a square) on the small red square at the left end of the longer leg until the pointer changes to a crosshair. Then press the left mouse button. This point should now be marked by a larger red circle as shown in the figure above.

In this dialog box, the option *Reduce section into individual elements* is to be activated as well by ticking the respective check box.

To set the section, steer the crosshair-shaped pointer on node 2 in the graphics. The angle section can be seen as a dotted line attached to the defined offset point. As soon as node 2 with its coordinates appears in the status bar, press the left mouse button.

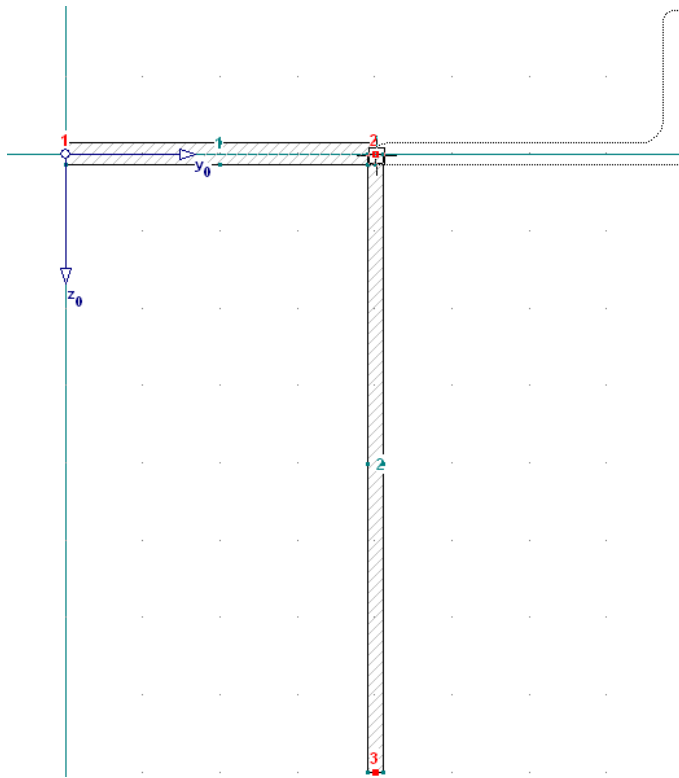

Figure 3.11: Setting the angle section on node 2

3.3.5 Mirror Elements

As both of the newly set elements are still selected (i.e. colored in the graphics and tables), we can mirror the angle right away. If the elements are not marked, either hold down the [Shift] key while clicking on both elements or simply pull up a window over them.



To mirror the two elements, call up menu **Edit** → **Mirror/Copy** or press the corresponding button in the toolbar. The *Mirror* dialog box appears.

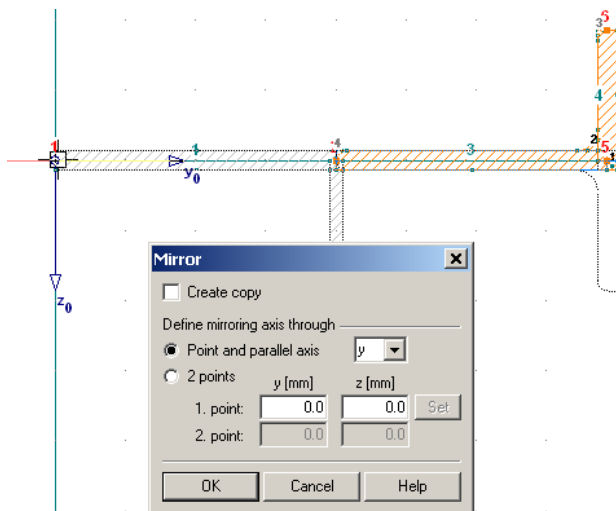

Figure 3.12: Dialog box *Mirror*

Make sure that *Create Copy* is **not** checked in this dialog box. The *Mirroring Axis* can be defined via **Point and Parallel Axis y** so that the default setting is applicable. Now move the mouse pointer to node 1, 4 or 5. As soon as the box shows the 1st Point with its correct coordinate $z = 0.0 \text{ mm}$, you can mirror the angle by clicking with the left mouse button.

3.3.6 Set and Delete Point Elements



The splice still has to be reworked a bit. Zoom in on the area around node 2 by activating the **View** → **Zoom** menu or the corresponding button in the toolbar.

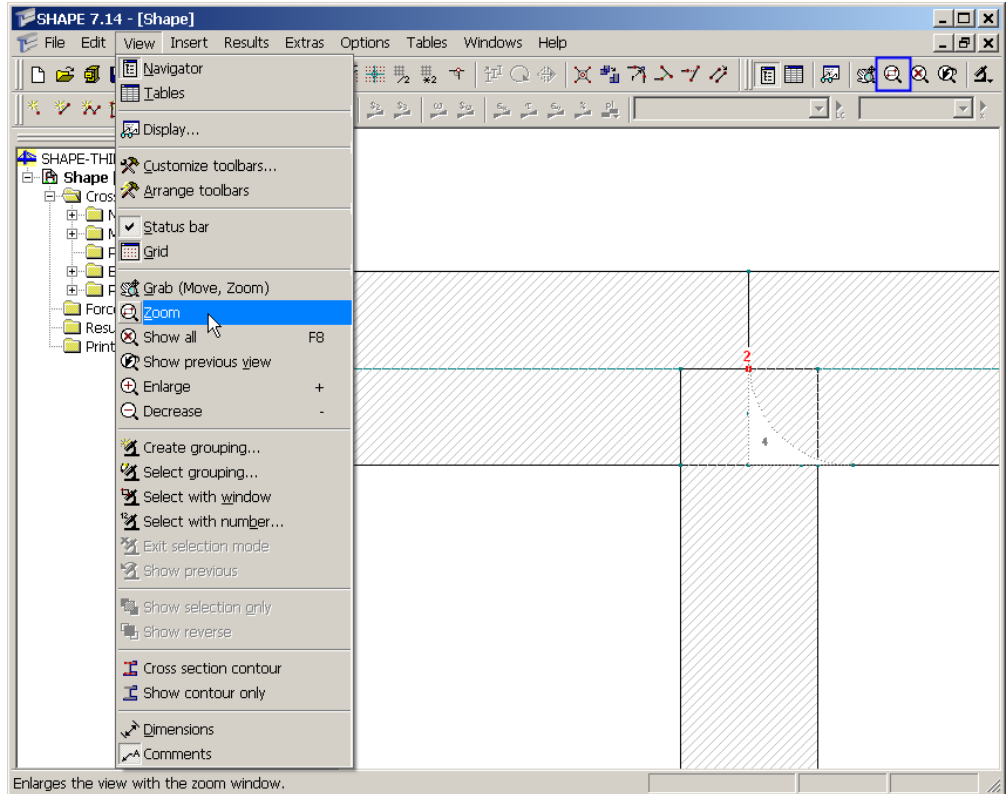

Figure 3.13: Menu **View** → **Zoom**



The 6 mm weld with concave shape is modeled as so-called *Point Element* with 15 mm seam length. Via menu **Insert** → **Point Elements** → **Graphics** or the related button, you can call up the dialog box *Set Point Element*.

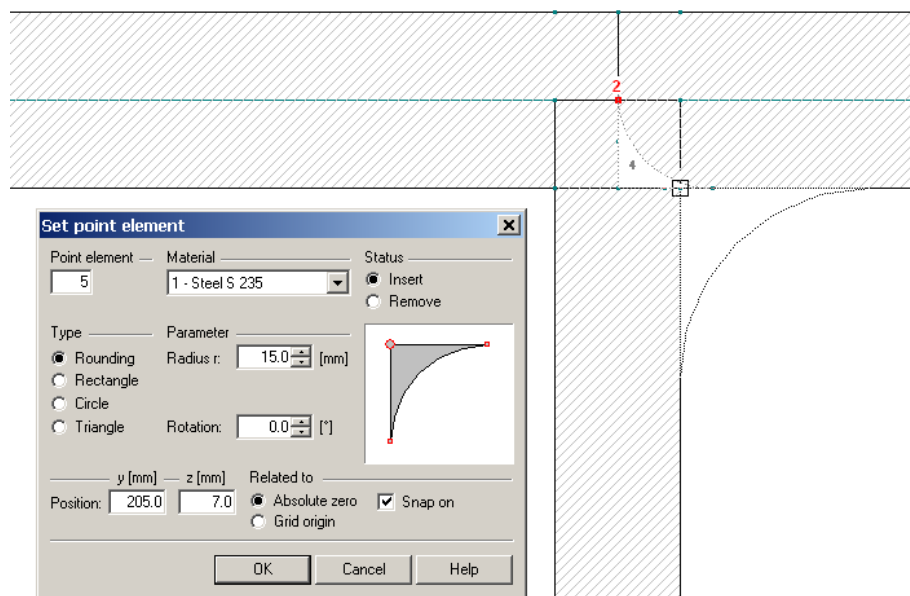

Figure 3.14: Dialog box *Set point element*

The default settings of this dialog box are suited for the weld, apart from the **Radius r** that you can change to **15 mm** in the input field. Now move the crosshair-shaped pointer precisely on the contours intersection of elements **2** and **3**. As soon as the dotted shape of the point element has reached the *Position* $y = 205.0 \text{ mm}$, $z = 7.0 \text{ mm}$ as seen in the above figure, press the left mouse button. Then cancel the command by a right-mouse click or via [Esc].

The point element **4** represents an unwanted opening that results from mirroring the rolled angle. The fastest way to remove this point element is to right-mouse click it and then to choose **Delete Point Elements** in the context menu.

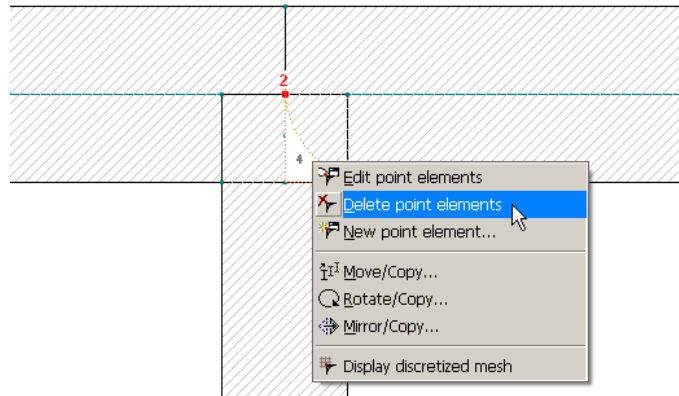

Figure 3.15: Deleting point element 4 via context menu



The button [Show All] or the [F8] key fills the work area with the updated input of our section.

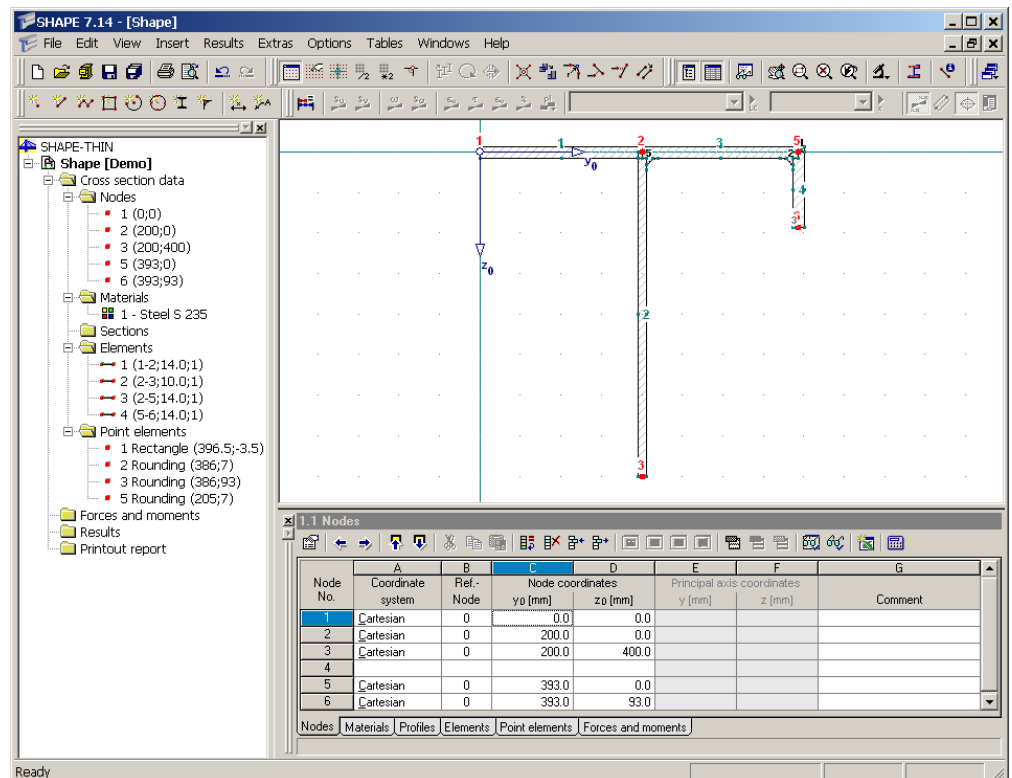

Figure 3.16: Result of the graphical input

3.3.7 Insert Opening

The bolt hole in the top flange can be modeled via the **Edit → Insert Opening in Element** menu which calls up the following dialog box.

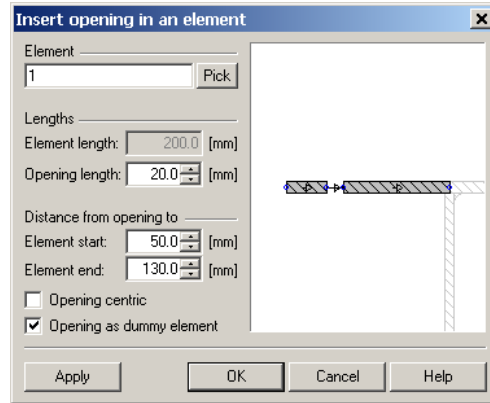

Figure 3.17: Dialog box *Insert opening in an element*

Click the [Pick] button and then select element 1 in the graphics by a mouse click. Right-mouse clicking in the work area takes you back to the initial dialog box. Now enter the *Opening Length* of 20 mm at a *Distance* of 50 mm from the *Element Start*. The zoomed image in this dialog box is dynamical with the input, and it also gives information on the element direction.

[OK] then inserts the opening. Element 1 is divided by two nodes. A *Null* element is created with the thickness $t = 0.00$ mm to model the hole as a shear-stiff connection.

Demo Version



If you try this example in the demo version, there will be a problem when this section is to be calculated later because the demo restriction confines the analysis to only four elements. For the demo version, it is therefore recommended to proceed without this opening: Click the [Undo] button to restore the original state of element 1.

3.3.8 Plausibility Check and Save

The input is checked with the **Extras → Plausibility Check** menu.

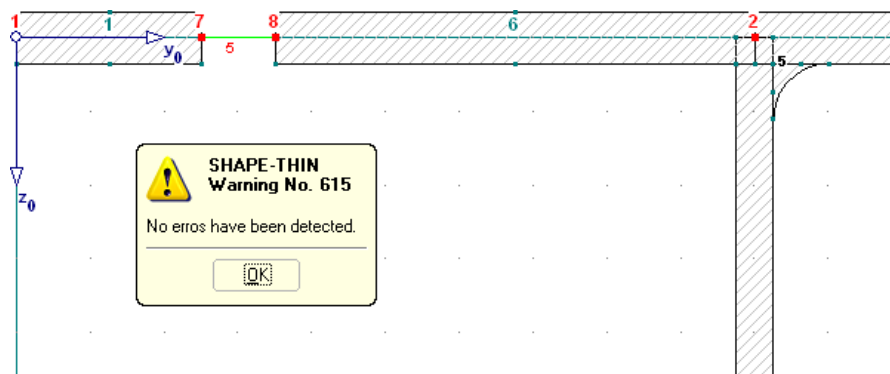

Figure 3.18: Plausibility check



Save the data with the **File → Save** menu or the corresponding button as seen to the left. (In the demo version, saving the file will not be possible if the opening is included.)

3.3.9 Check Input Tables



SHAPE offers several possibilities to define the data. All graphical input is automatically entered in the corresponding input tables at the bottom of the screen, and vice versa. If the tables are not shown, open them with the **View** → **Tables** menu or the button as seen to the left.

There are six distinct input tables:

- 1.1 Nodes
- 1.2 Materials
- 1.3 Sections
- 1.4 Elements
- 1.5 Point Elements
- 1.7 Forces and Moments

Move between the tables by clicking on the register tabs below the tables. The graphic input done in the example so far can be found in the *Nodes*, *Elements* and *Point elements* tables.

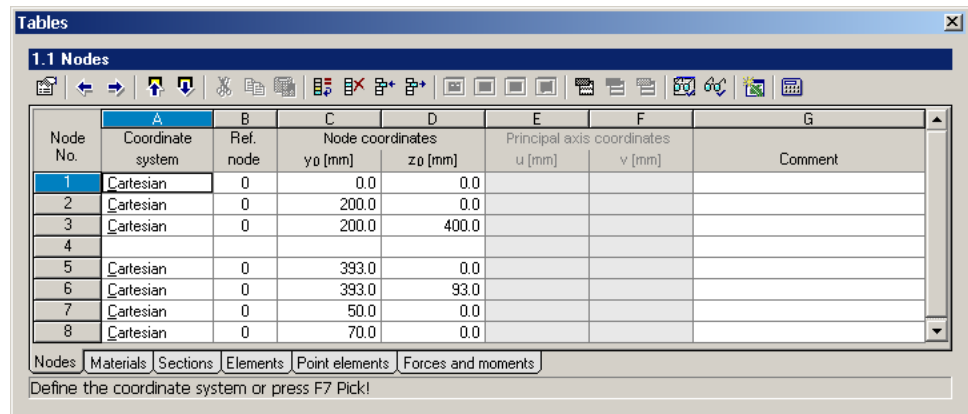

Node No.	A Coordinate system	B Ref. node	C Node coordinates		E Principal axis coordinates		G Comment
			yo [mm]	zo [mm]	u [mm]	v [mm]	
1	Cartesian	0	0.0	0.0			
2	Cartesian	0	200.0	0.0			
3	Cartesian	0	200.0	400.0			
4							
5	Cartesian	0	393.0	0.0			
6	Cartesian	0	393.0	93.0			
7	Cartesian	0	50.0	0.0			
8	Cartesian	0	70.0	0.0			

Figure 3.19: Table 1.1 Nodes

There is still no input for the *Principal axis coordinates* in the first table. The program will automatically put in these results after the analysis of the section.

As the rolled angle section was split up into individual elements when setting it, the table 1.3 Sections is empty.

Table 1.4 Elements lists the *Thickness* and *Material* of every element, plus *Length*, *Direction* and *Area*.

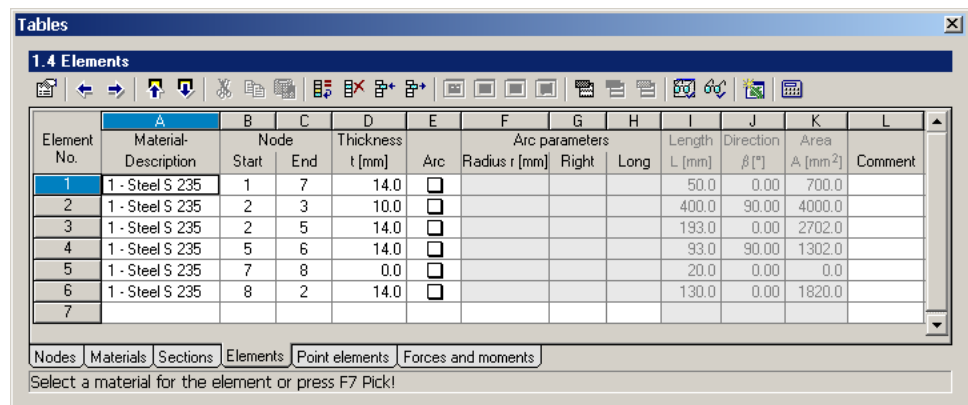

Element No.	A Material-Description	B Node		D Thickness t [mm]	E Arc	F Arc parameters			I Length L [mm]	J Direction β [°]	K Area A [mm²]	L Comment
		Start	End			Radius r [mm]	Right	Long				
1	1 - Steel S 235	1	7	14.0	<input type="checkbox"/>				50.0	0.00	700.0	
2	1 - Steel S 235	2	3	10.0	<input type="checkbox"/>				400.0	90.00	4000.0	
3	1 - Steel S 235	2	5	14.0	<input type="checkbox"/>				193.0	0.00	2702.0	
4	1 - Steel S 235	5	6	14.0	<input type="checkbox"/>				93.0	90.00	1302.0	
5	1 - Steel S 235	7	8	0.0	<input type="checkbox"/>				20.0	0.00	0.0	
6	1 - Steel S 235	8	2	14.0	<input type="checkbox"/>				130.0	0.00	1820.0	
7												

Figure 3.20: Table 1.2 Elements

In the 1.5 *Point Elements* table, all inserted or removed point elements are compiled. The weld seam is contained in row 5.

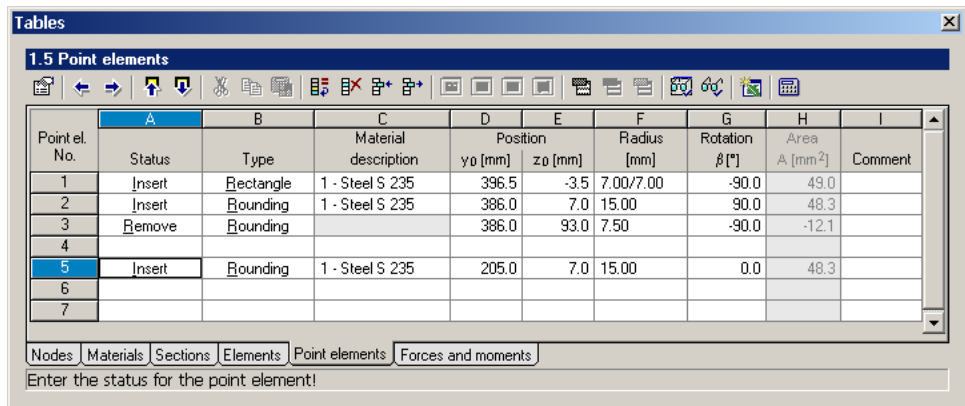

Point el. No.	A	B	C	D		E	F	G	H	I
	Status	Type	Material description	y ₀ [mm]	z ₀ [mm]	Radius [mm]	Rotation β [°]	Area A [mm ²]	Comment	
1	Insert	Rectangle	1 - Steel S 235	396.5	-3.5	7.00/7.00	-90.0	49.0		
2	Insert	Rounding	1 - Steel S 235	386.0	7.0	15.00	90.0	48.3		
3	Remove	Rounding		386.0	93.0	7.50	-90.0	-12.1		
4										
5	Insert	Rounding	1 - Steel S 235	205.0	7.0	15.00	0.0	48.3		
6										
7										

Figure 3.21: Table 1.5: *Point elements*



As the geometrical input of our example requires no changes, click the **Materials** tab or move to that table with the [←][→] buttons in the table toolbar.

3.3.10 Edit Material

In table 1.2 *Materials*, the material characteristics and limit stresses are defined.

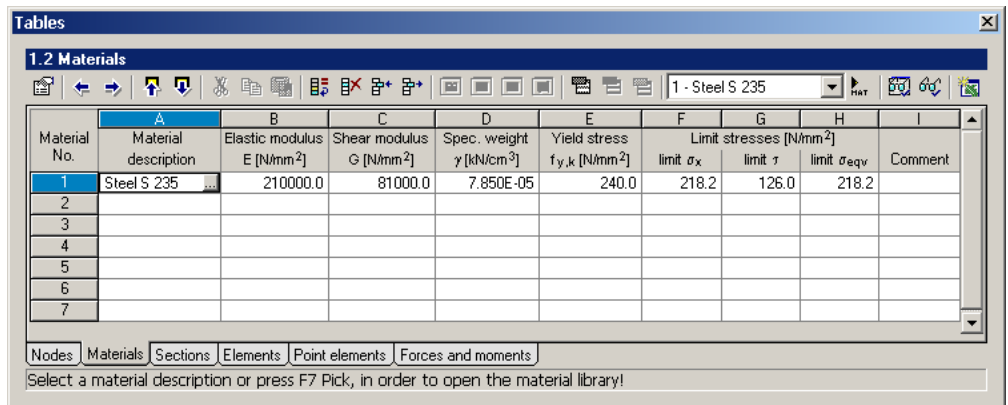

Material No.	A	B	C	D	E	G			I
	Material description	Elastic modulus E [N/mm ²]	Shear modulus G [N/mm ²]	Spec. weight γ [kN/cm ³]	Yield stress f _{y,k} [N/mm ²]	Limit stress limit σ _x	limit τ	limit σ _{eqv}	Comment
1	Steel S 235	210000.0	81000.0	7.850E-05	240.0	218.2	126.0	218.2	
2									
3									
4									
5									
6									
7									

Figure 3.22: Table 1.2 *Materials*



Steel S 235 was set as default for all elements. To access the material library, click this steel grade in the *Material Description* column and then on the small button within the input field (see above). The **Material Library** is called up.

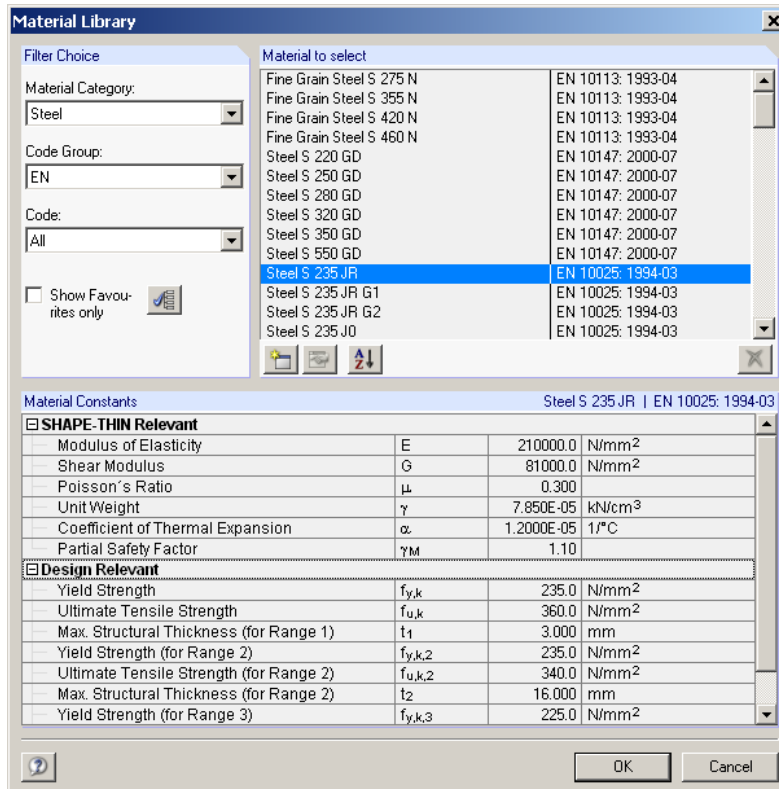

Figure 3.23: Dialog box *Material Library*

In the dialog section *Filter Choice* to the left, select the *Code Group* **EN** from the list. Click the steel grade **Steel S 235 JR** in the section *Material to Select* and then click [OK].

The new material characteristics and the *Limit Stresses* σ_x , τ and σ_{eqv} are imported into the *Materials* table. This input table is now complete, as a *Comment* is only optional.

3.3.11 Define Internal Forces



The internal forces (cf Table 3.1, page 11) can be entered in table 1.7 *Forces and Moments*. Move to this table by clicking on the corresponding tab or by using the [←][→] buttons as before.

There are two different constellations of internal forces. Instead of creating two different load cases, it is easier to specify two different design locations *x* within a single load case. In our example, those locations can be freely defined. With the first entry of a **Location x**, the new load case **LC1** is created automatically. Put in the internal forces as follows.

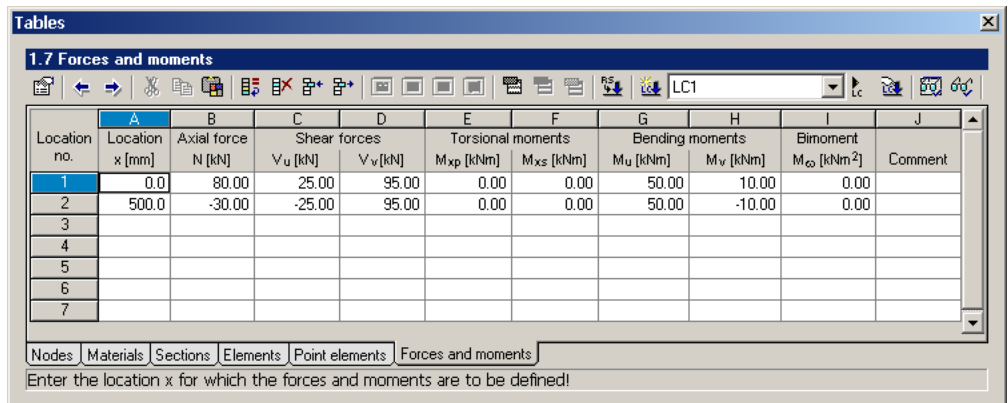

Location no.	Location x [mm]	Axial force N [kN]	Shear forces Vu [kN]	Vv [kN]	Torsional moments M _{xp} [kNm]	M _{xs} [kNm]	Bending moments Mu [kNm]	Mv [kNm]	Bimoment M _{co} [kNm ²]	Comment
1	0.0	80.00	25.00	95.00	0.00	0.00	50.00	-10.00	0.00	
2	500.0	-30.00	-25.00	95.00	0.00	0.00	50.00	-10.00	0.00	
3										
4										
5										
6										
7										

Figure 3.24: Table 1.7 *Forces and moments*

3.4 Calculation



The input is complete now. You can start the analysis of the section properties and stresses via the **Results** → **Display Results** menu or by clicking on the button as seen to the left. Pressing the function key [F5] has the same effect.

The results will be displayed after a quick calculation.

3.5 Results

The cross-section graphics show the

- principal axes u and v ,
- area bisection axes (dotted lines),
- centroid C ,
- inertia ellipse and
- shear center M .

In our example, the axis u represents the major principal axis.

In table 2.1 *Section Properties*, the characteristics of the section are listed in detail.

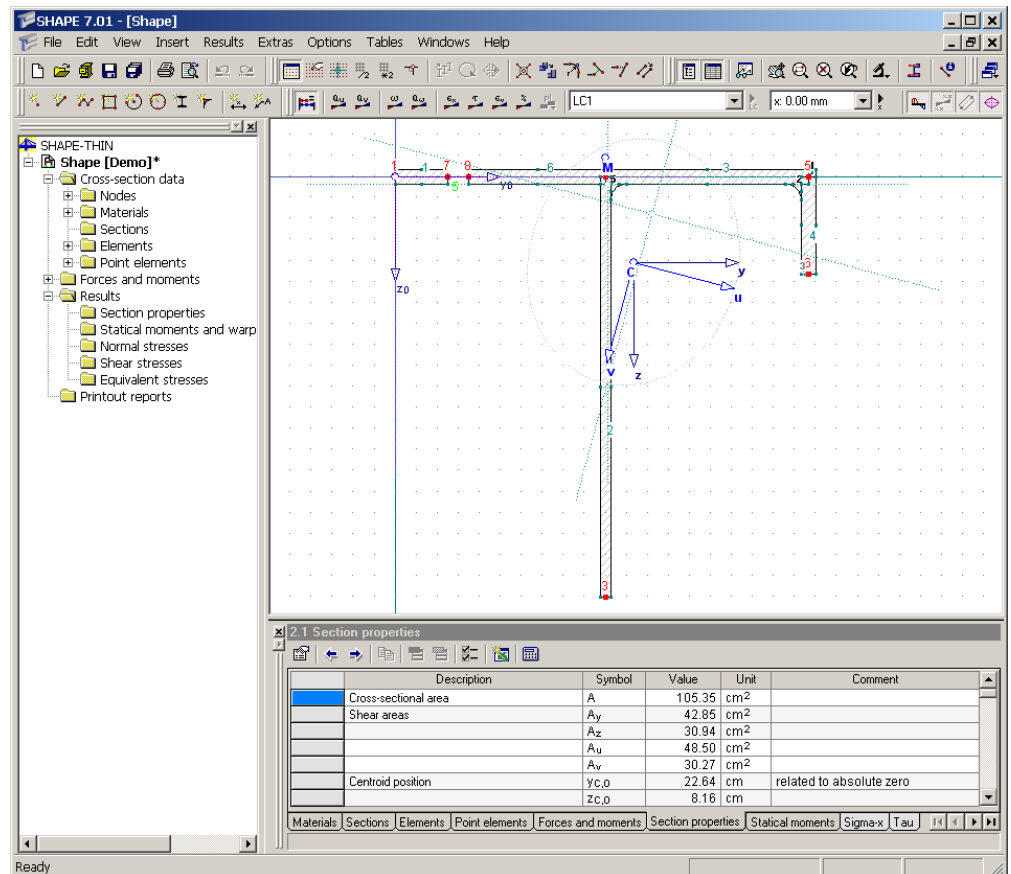

Figure 3.25: Section after the analysis

3.5.1 Select Results

The display of the section properties or stresses can be controlled with the *Results* menu.

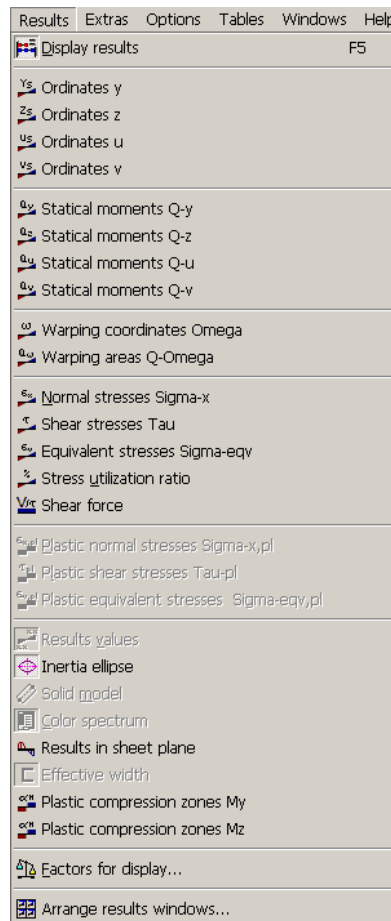

Figure 3.26: *Results* menu



The *Results* toolbar represents even faster options to evaluate the results graphically and to select among the load cases and locations *x*. It is possible to page forward to the next load case or location *x* with the [▶] buttons or by choosing them from the list.



Figure 3.27: Toolbar *Results*



Click the stresses [σ_x] button and make sure that the location $x = 0.00 \text{ mm}$ is set. The normal stresses will be displayed on the center lines of the section.

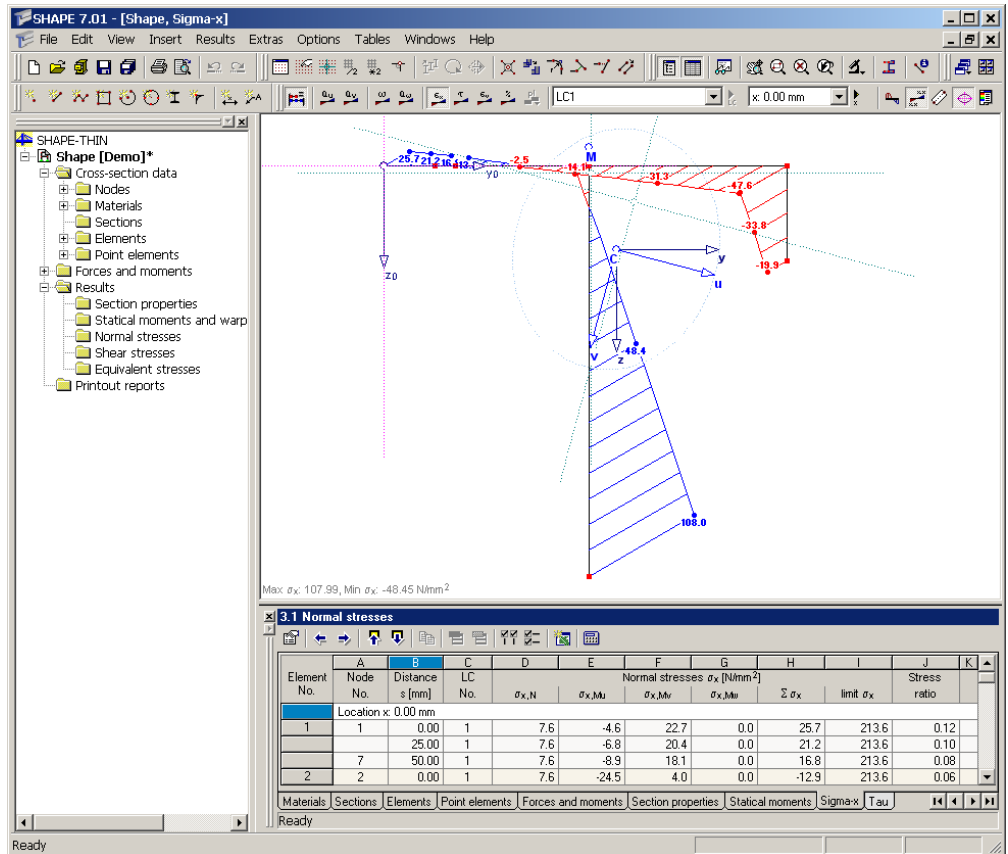

Figure 3.28: Normal stresses σ_x

Now click the **Sigma-x** folder tab of the input tables to open the 3.1 *Normal Stresses* table. There you can read the normal stresses in detail that result from the individual internal forces at both design locations x. The stresses for every *Element* can be identified on both end nodes and the element center (column *Distance s*).



Via menu **Results** → **Color Spectrum** or the corresponding button in the toolbar, you can display the normal stresses as isosurfaces on the section.

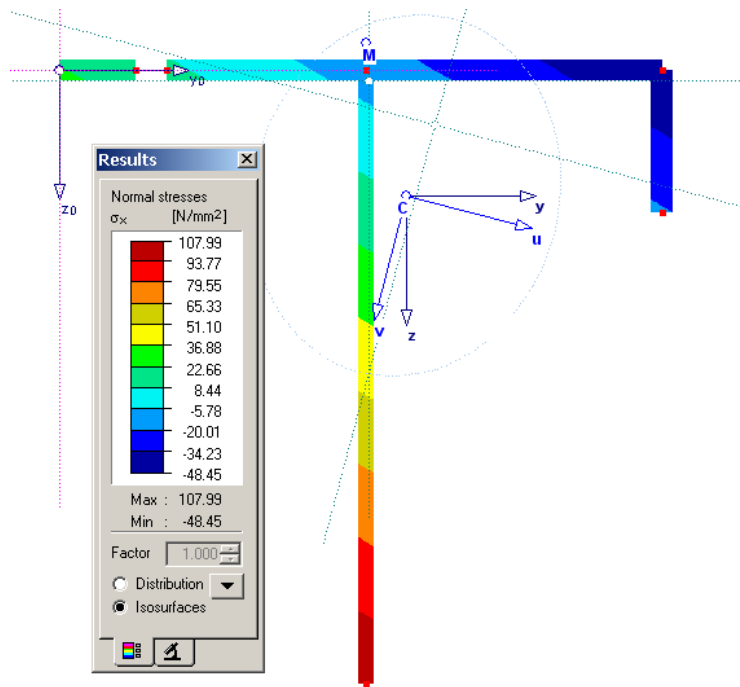

Figure 3.29: Normal stresses as isosurfaces

You can skim through the different types of results both graphically and numerically now.

3.5.2 Arrange Results Windows



It is possible to display several results simultaneously. Click the button as seen left or call up menu **Results** → **Arrange Results Windows**. The *Results - Display Options* dialog box opens. For our example, select the *Statical Moments* Q_u and Q_v to be shown exclusively.

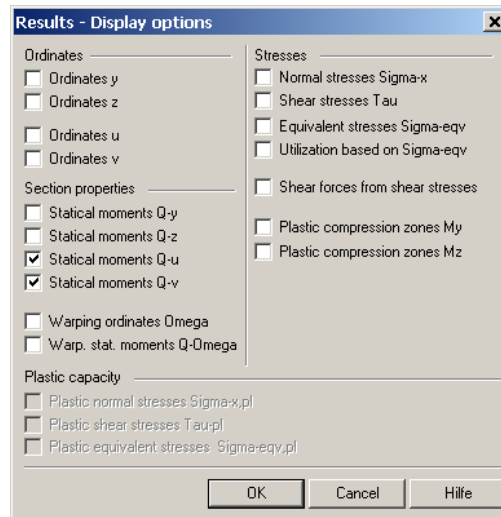

Figure 3.30: Dialog box *Results - Display options*

After clicking on [OK], a partitioned window opens with both of the selected cross-section characteristics. The illustration the numbering can be disabled for both views (cf Figure 3.5, page 14). When you now open the *2.2 Property Distribution* table by clicking on the corresponding folder tab, the screen looks like the following.

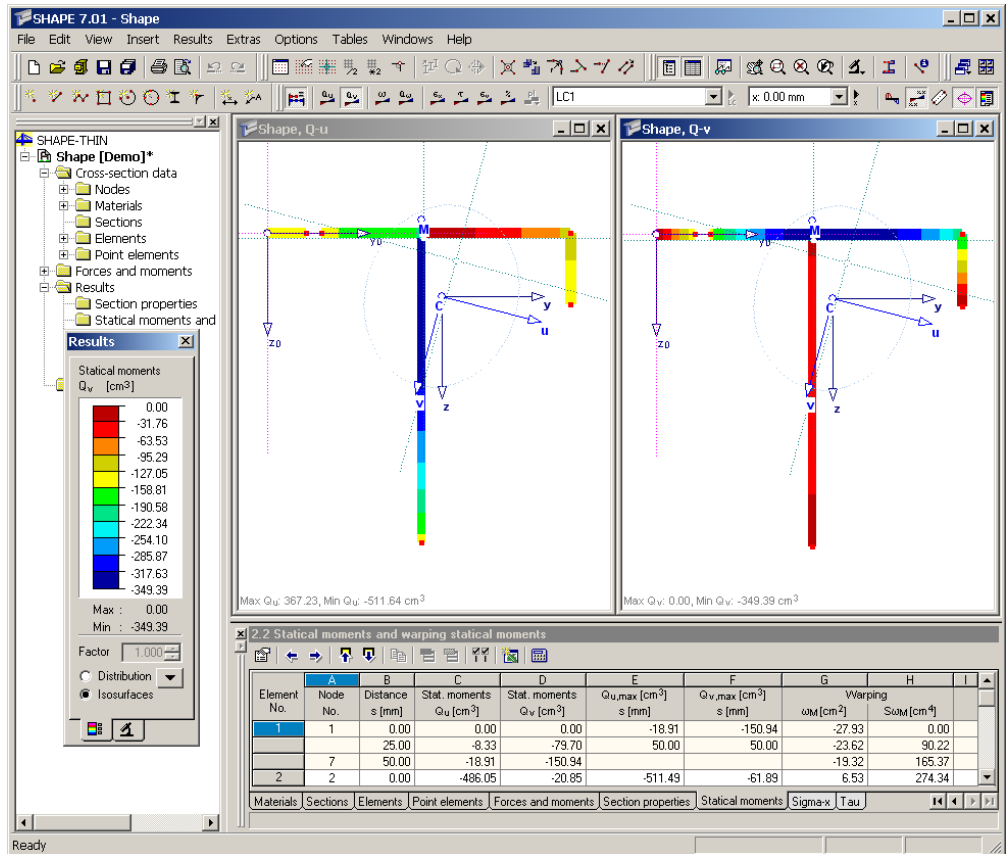

Figure 3.31: Static moments Q_u and Q_v

3.5.3 Printout Report



To document the screen view above in the printout report, click the [Print] button in the toolbar or select the File → Print menu. The *Print image* dialog box is opened.

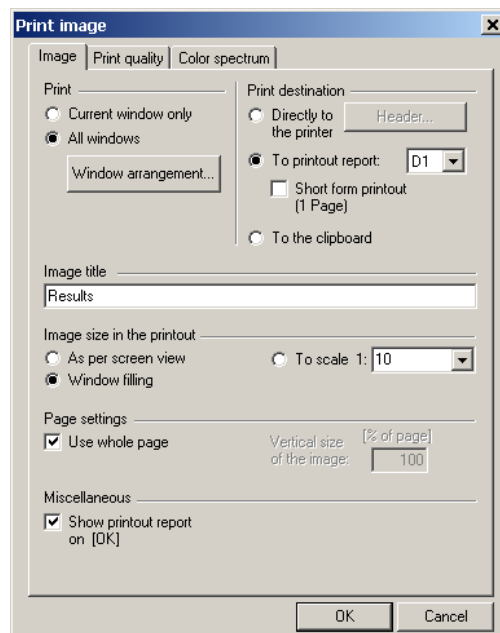

Figure 3.32: Dialog box *Print image*

As seen in the image above, choose the following settings.

- *Print* All windows
- *Print destination* To printout report (no short form printout)
- *Image size* Window filling
- *Page settings* Use whole page

Window arrangement...

Click the [Window arrangement] button to define how the graphics are to be arranged on the sheet.

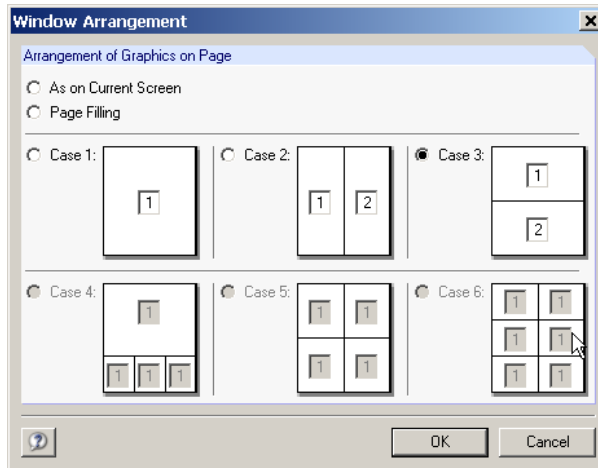

Figure 3.33: Dialog box *Window Arrangement*

For the *Arrangement of Graphics on Page*, select **Case 3** and then confirm this with [OK].

The two tabs *Print quality* and *Color spectrum* in the previous *Print image* dialog box contain more options for the printout, e.g. print color, frame, position of color spectrum, which you can quickly check.

If you accept those settings, confirm the dialog box with [OK] to start printing the image to the printout report. This preview of the print data appears after a short while.

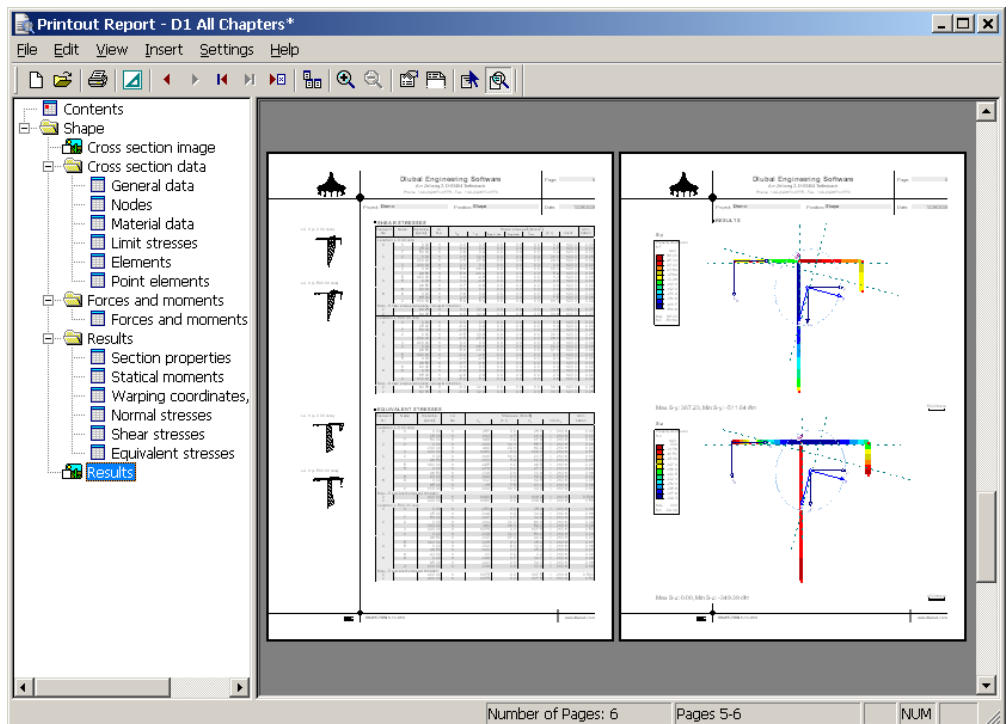

Figure 3.34: Printout report with results graphics



The printout report is a separate section of the SHAPE program and consists of a two-part layout. To the left is the *Print Navigator* where the contents of the printout report are seen in a hierarchal list. Like the Windows Explorer, the topics are opened and closed by clicking on the [+] and [-] buttons respectively.

Using the Drag & Drop function, topics can be moved to rearrange the contents. We will apply this function now to place our image of the statical moments – which was added at the end of the printout report – at a different location: Click the left mouse button on the *Results* graphics in the Print Navigator, drag it over *Statical Moments* and release the mouse button.

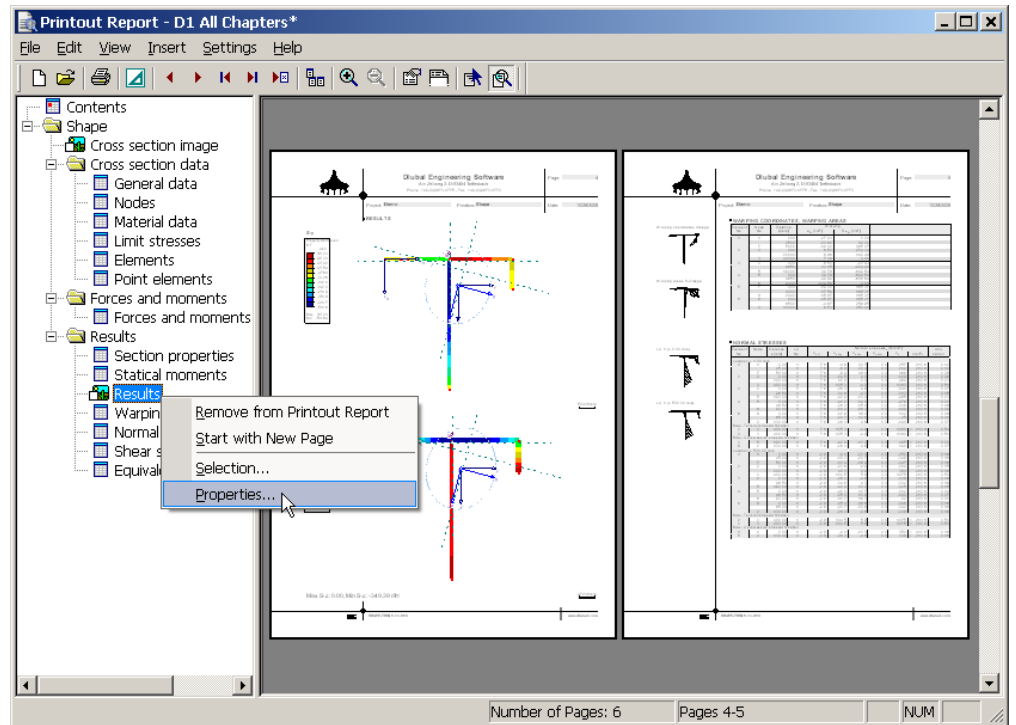

Figure 3.35: Printout report: Moving graphics and context menu

Clicking the right mouse button on any topic in the Print Navigator opens a context menu with more settings. To change the headline of the image, click the *Properties* option in the context menu and type in **Statical Moments Q-u and Q-v** as new *Title*.

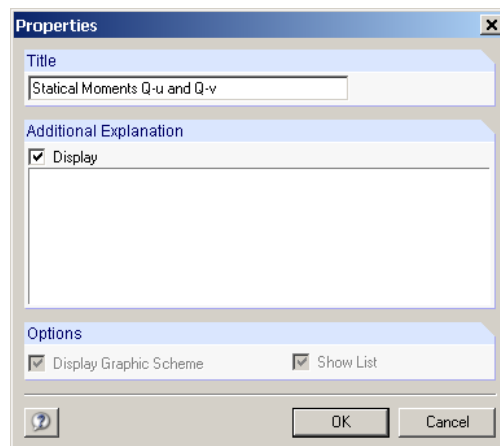

Figure 3.36: Dialog box Properties

After [OK], the printout report will be created with the modified image.



When the printout report has been completely arranged, it can be finally sent to the printer via menu **File** → **Print** or the corresponding button in the printout report.

3.6 Outlook

This concludes our introductory example. We hope that we could give you a short overview and made you curious to discover more of the program functions on your own. Detailed descriptions of all SHAPE functions follow in the next chapters of this manual.

The SHAPE online help which is based on this manual can be opened via menu **Help** or [F1].

4. User Interface

4.1 Overview

When you open one of the demo examples in SHAPE, your screen should look as shown in figure 4.1. The user interface conforms to the usual Windows™ standards.

The following figure shows the most important areas.

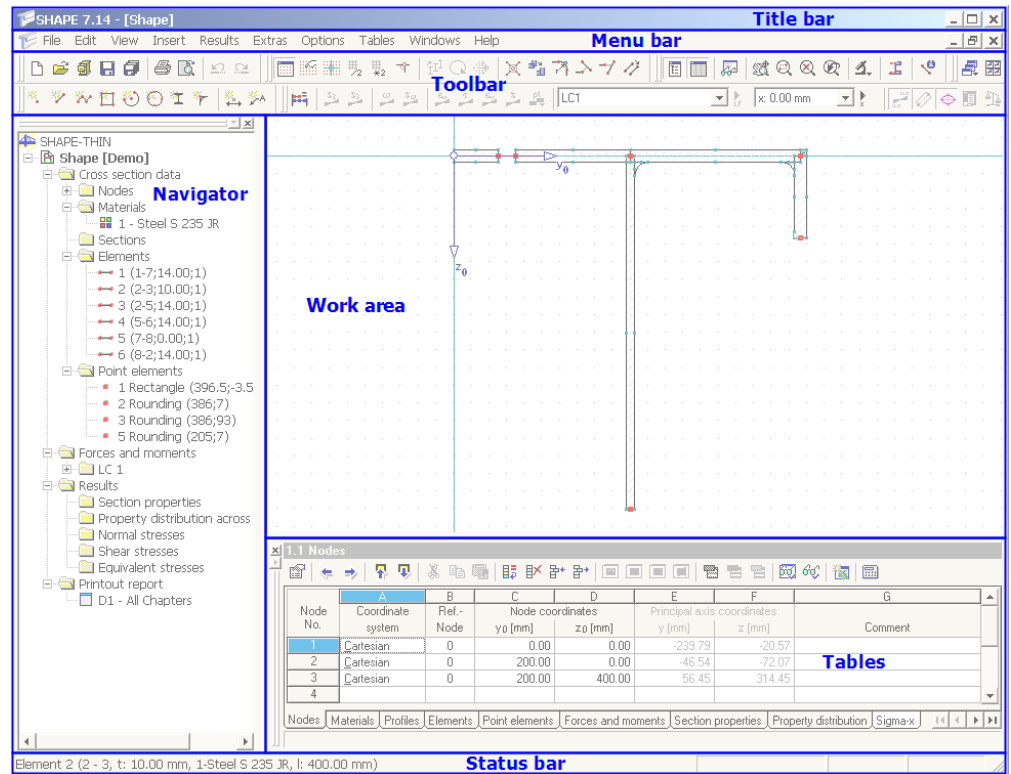
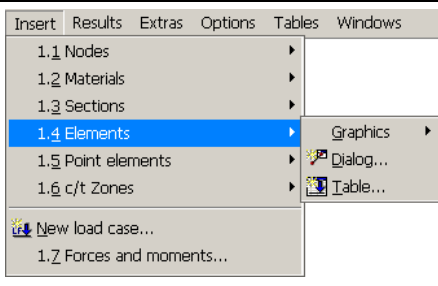

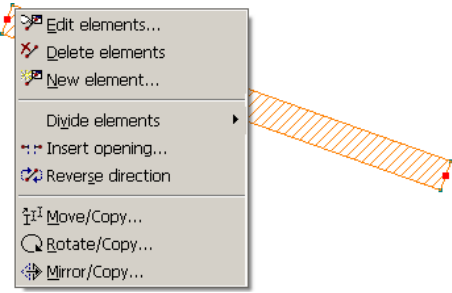

Figure 4.1: SHAPE user interface

4.2 Terminology

This chapter explains some important terms of the Windows™ user interface that are frequently used in this manual.

Different expressions are used to describe the individual elements of the user interface. The following table lists the most common expressions.

Term	Figure	Synonym	Explanation
Menu		Pulldown Menu	Commands and functions below the title bar

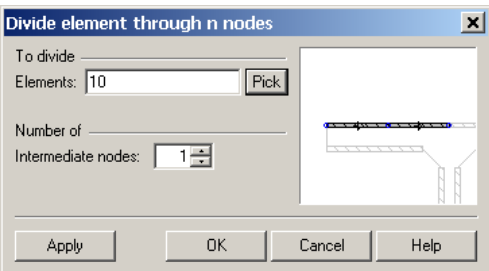
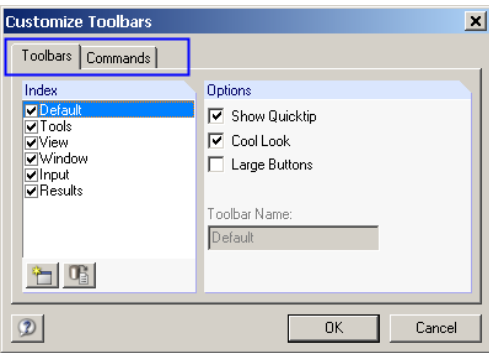
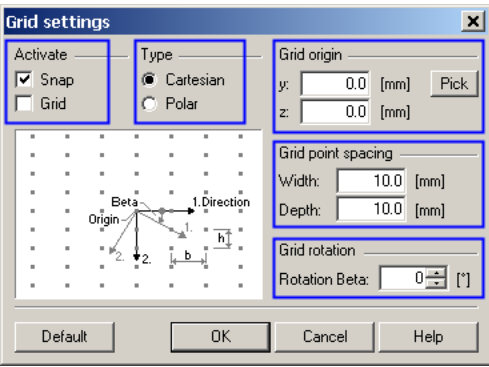
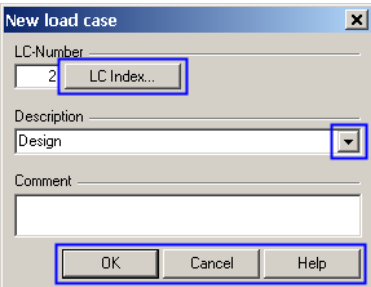
<p>Context Menu</p>		<p>Pop-up Menu</p>	<p>The context menu can be activated by a right mouse click.</p> <p>It contains useful items for the selected object.</p>
<p>Toolbar</p>		<p>Button Bar</p>	<p>Collection of buttons beneath the menu bar</p>
<p>Dialog Box</p>			<p>A window which is opened in the main window for the user to enter data.</p>
<p>Tab</p>		<p>Register</p>	<p>Extensive dialog boxes are structured by several tabs.</p> <p>Clicking a tab activates the appropriate index card.</p>
<p>Section</p>		<p>Group, Frame</p>	<p>Various elements in a dialog box that belong together logically.</p>
<p>Button</p>		<p>Icon</p>	<p>Clicking a button starts an action, e.g. a new dialog box is opened or changes take effect.</p>

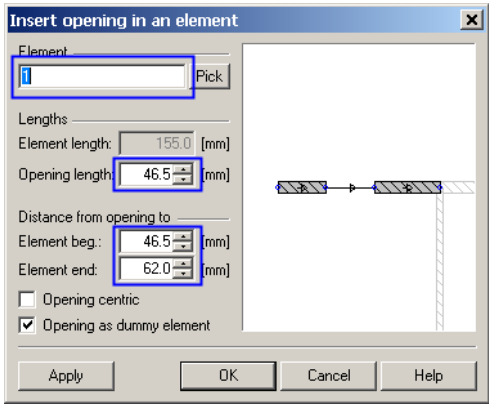
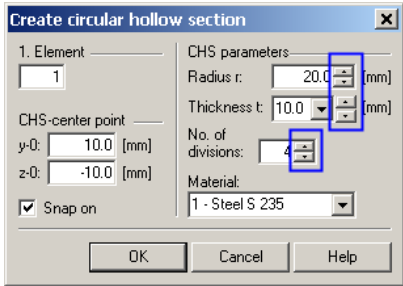
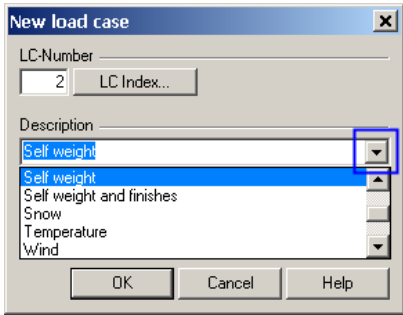
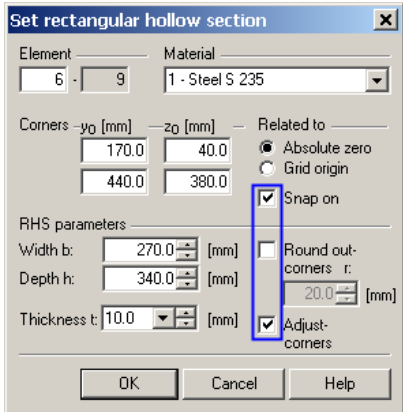
<p>Input Field</p>		<p>Input Box, Input Line</p>	<p>Space for text or numbers to be entered</p>
<p>Spin Button</p>		<p>Spinner</p>	<p>Two tiny buttons at the end of an input field to increase resp. decrease the numerical values.</p>
<p>List</p>		<p>List Box, Combo Box</p>	<p>Offers a selection of options to choose from. Sometimes user-defined terms can be included in the list.</p>
<p>Check Box</p>			<p>Yes/No inquiry for specific choices.</p>

<p>Selection Field</p>		<p>Radio Button</p>	<p>Selection among several options. Only one of these alternatives can be true.</p>
<p>Slide Control</p>			<p>“Continuously” adjustable controller for certain features.</p>
<p>Tree Structure</p>		<p>Tree Diagram</p>	<p>Arrangement of information similar to the Windows Explorer.</p>

Table 4.1: Terminology

4.3 SHAPE User Interface

This chapter describes the individual operating elements of SHAPE (cf Figure 4.1, page 32). The program follows the general standards for Windows™ applications.

4.3.1 Menu Bar

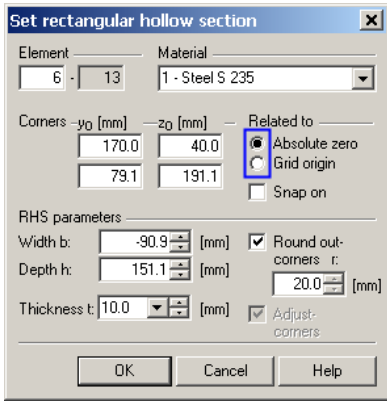
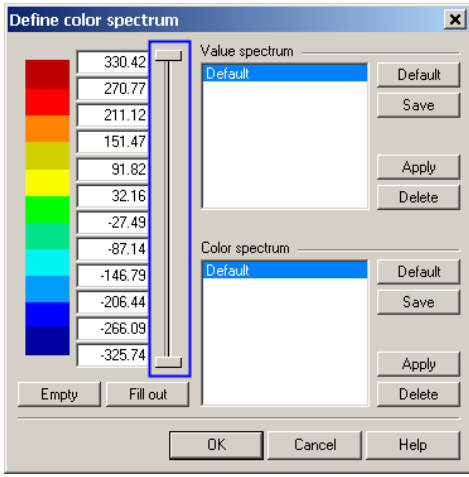
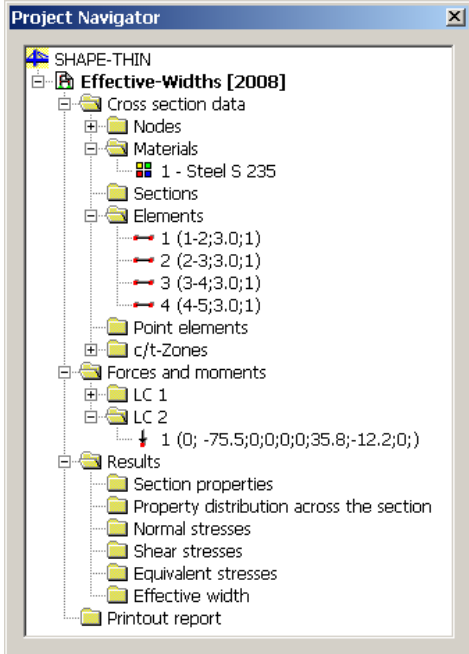
The SHAPE menu beneath the title bar contains all program functions. They are organized in logical blocks.

A menu can be opened by clicking with the right mouse button or activating the keyboard by pressing the [Alt] key in combination with the underlined letter. The menu will open and the individual menu entries will be accessible. The selection is again carried out either with the mouse or the keys of the underlined letters. A function can also be selected with the cursor keys [↑] and [↓] and then started with the [↵] key.

When a menu has been opened, you can move between the entries with [→] and [←].

Next to some menu items, so-called hot keys are specified. These keep with the Windows™ standards and can also be used to start certain functions, e.g. [Ctrl]+[S] save the data.

4.3.2 Toolbars

Beneath the menu bar, there is a collection of many buttons which permit direct access to the most important functions. When the mouse pointer rests over a button for a moment, a short info text will be displayed as *Tooltip*.

It is possible to customize the toolbars. The position can be changed by picking a toolbar at its left side and then moving it to a different location.

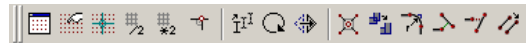

Figure 4.2: Toolbar

As soon as the toolbar is being moved to the work area, it is transformed to a “floating” bar within the active window.



Figure 4.3: Floating toolbar *Tools*

The toolbar can be moved back to its original place with the mouse or by double-clicking its headline.

Menu **View** → **Customize Toolbars** calls up a dialog box which makes it possible to change the contents and look of the toolbars.

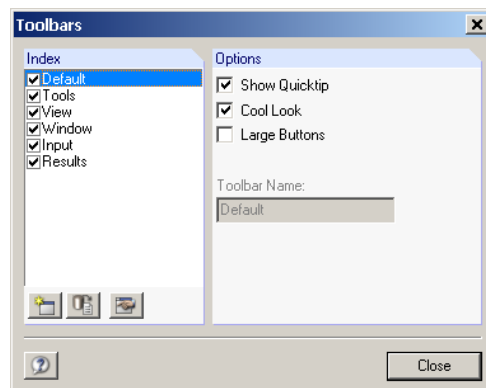

Figure 4.4: Dialog box *Toolbars*

All available toolbars are listed in this dialog box. If a toolbar is visible, its check box in section *Index* is activated. If a toolbar is to be made invisible, the appropriate check box can be disabled with a mouse click.



After clicking on button [New Toolbar...], a user-defined toolbar can be created.

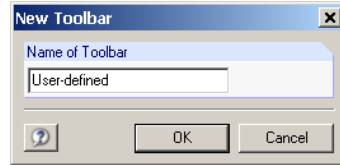

Figure 4.5: Creating a new toolbar

A dialog box is opened in which the name of the new toolbar can be entered. After [OK], the new tab *Commands* is available in the *Customize Toolbar* dialog box (see below) where the individual buttons can be assigned to the new toolbar.

The description of a user-defined toolbar can be changed in the input field *Toolbar Name*.



[Default] resets everything to the original state. If a user-defined toolbar is marked in the list on the left, it will be removed. The default toolbars cannot be removed, only hidden.

Three checkboxes are available for the look and features of the buttons.

<i>Show Quicktip</i>	When the pointer is moved over a button, a short explanation of its function appears.
<i>Cool Look</i>	A button emerges when the pointer is placed on it.
<i>Large buttons</i>	The buttons are drawn to a larger scale.

Table 4.2: Options for the button display

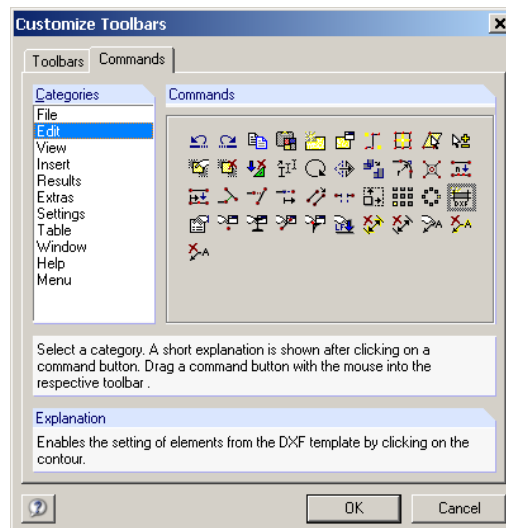

Figure 4.6: Dialog box *Customize Toolbars*, *Commands* tab

The *Commands* tab of the dialog box is accessible when a new toolbar is created or when you have activated the button [Customize toolbars]. The contents of the single toolbars can be modified in the second tab of this dialog box. All commands are assigned to certain categories. When a category has been selected, all command buttons belonging to this category are displayed to the right side. Click one of these buttons to get a short explanation of its function in dialog box section *Explanation*. The buttons can be moved to any toolbar by drag & drop.

To remove a button from a toolbar, press the [Alt] key and drag the button to the work area.

4.3.3 Navigator



The navigator is displayed on the left side of the work window. It can be switched on and off with the corresponding button in the *View* toolbar or via menu **View** → **Navigator**.



Figure 4.7: Button [Display navigator] in the *View* toolbar

In its handling, the navigator is similar to a toolbar. It can be picked with the mouse at its top edge and then be moved to the work area. Double-clicking the headline or moving it to the left or right margin will dock it again.



A clearly arranged tree structure presents all data of a selected structure. [+] opens the branches of this tree, [-] shuts them again. Double-clicking on the entry has the same effect.

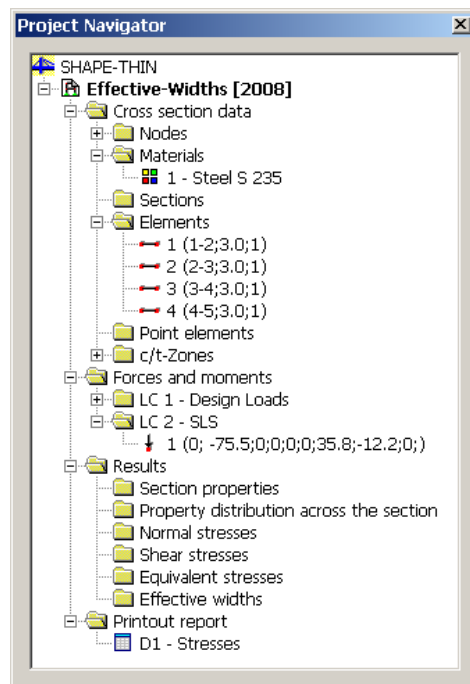

Figure 4.8: Navigator

All input and results data are listed in this navigator. Double-clicking an entry (a “leaf” of this tree) calls up a dialog box to modify the item. When clicking on an entry with the right mouse button, a context menu appears which contains the most important functions relevant for this item.

Objects that have been defined incorrectly are marked by an asterisk.

4.3.4 Tables



The numerical tables are arranged at the bottom edge of the SHAPE window. They can be switched on and off via the **View** → **Tables** menu or the appropriate button in the **View** toolbar.

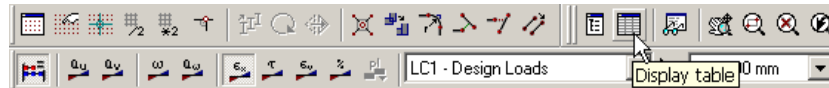

Figure 4.9: Button [Display table] in the View toolbar

All data can be entered numerically in the tables. Several powerful functions enable a very effective input (for details see chapter 10.3, page 181).

Working through the tables successively warrants that all data will be included. The tables reflect the internal organization of the SHAPE data. For this reason, the structure of chapters 5 and 7 in this manual corresponds with the table sequence.

In its handling, the table is similar to a toolbar. It can be picked with the mouse at its top edge and then be moved to the desktop. Double-clicking the headline or moving it to the one of the margins will dock it again.



When a row has been selected in the table, this element is highlighted in the graphics above. Vice versa, the corresponding row is highlighted in the table if an object has been selected in the graphics. This synchronization of the selection can be controlled via menu **Tables** → **Settings** or with the two buttons shown on the left.

4.3.5 Status Bar

The status bar represents the bottom end of the SHAPE window. Menu **View** → **Status Bar** switches it on and off.

The status bar consists of two areas.

Left Area

Element 1, s: 108.3 mm, t: 6.0 mm, Sigma-x: -133.6 N/mm²

Figure 4.10: Status bar, left area

The text that is shown here varies according to the active program function. If the mouse pointer is above an object of the graphical desktop, some further information is given on this.

Please keep an eye on this part of the status bar. Useful information will be given about buttons or input fields in dialog boxes.

Right Area

Y=200.0 mm Z=0.0 mm

Figure 4.11: Status Bar, right area

This part of the status bar shows the current coordinates of the nodes or of the mouse pointer when setting elements or nodes.

4.3.6 Control Panel



When displaying stresses or utilizations, several parameters with regard to view and control of the display are accessible through the **Panel**. The menu

Results → Color Spectrum

or the corresponding button opens and closes this panel.

This panel has two folder tabs.

Color Spectrum

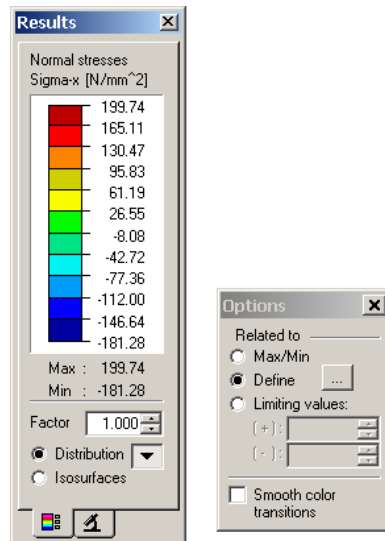

Figure 4.12: Panel - *Color Spectrum* tab with activated button [▼]

When a multi-color view was selected, this tab will show the color spectrum with the assigned value areas. A color spectrum of eleven colors is set by default, covering the extreme values in equidistant intervals.



The color spectrum can be edited by double-clicking one of the colors. You can also use the details button [▼] on the bottom right and then *Define* the values of the isosurfaces and the color spectra by clicking on the [...] button. The following dialog box appears:

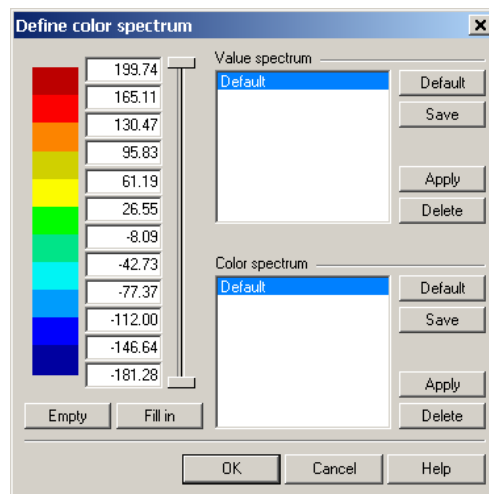

Figure 4.13: Dialog box *Define Color Spectrum*

By means of the two vertical slide buttons to the right of the values, the number of colors can be reduced from both sides. In addition, every color can be modified by double-clicking the color box.

You can also adjust the values of the spectrum according to your needs. However, a consequently ascending resp. descending order has to be observed. The buttons in the dialog section *Value Spectrum* help with assigning values. Their meanings are as follows:

Button	Function
Default	The eleven color zones are set to default.
Save	The value spectrum is saved as a global sample.
Apply	The current settings take effect for the results display.
Delete	The user-defined value resp. color spectrum is deleted.
Empty	All values in the input boxes are deleted.
Fill in	The values are equidistantly intercalated between maximum and minimum depending on the number of color zones.

Table 4.3: Buttons in dialog box *Define Color Spectrum*



When the details button [▼] is activated, additional settings are available in a small dialog box.

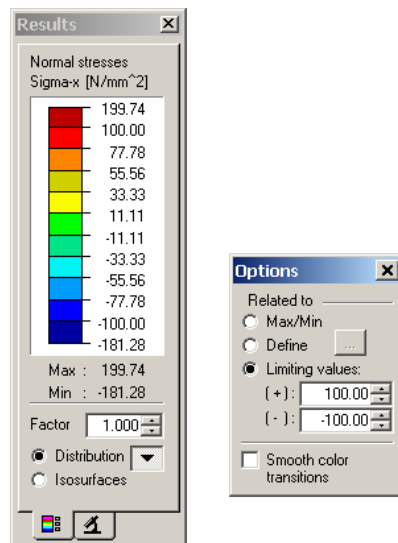

Figure 4.14: Dialog box *Options*, *Limiting values +/-*

The option *Limiting Values* allows for a detailed evaluation within a defined area. Every excess of the top or bottom limits will be covered by a single color. For example, the figure above implies the normal stresses within the interval of $\pm 100 \text{ N/mm}^2$ to be scaled in detail.

When the check box *Smooth Color Transition* is active, the distinct range borders of the ranges disappear. This option for a continuous color spectrum does not depend on the selected reference of the result values.

Filter

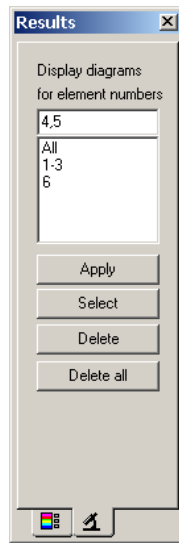

Figure 4.15: Panel - *Filter* tab

The *Color Spectrum* tab can be used to filter results in general. However, the *Filter* tab controls the result display for selected elements.

The numbers of the relevant elements can be entered in the input box *Display Diagrams for*. The filter function is carried out via [Apply]. The numbers can also be imported from the graphics via the [Select] button (multi-selection with window or pressed [Ctrl] key). Then the button [Apply] can be used.

4.3.7 Default Buttons

Certain buttons are used in many dialog boxes. When you let the mouse pointer hover on a button of the toolbar, a short description of its function will appear.

The following overview describes these default buttons.



















Button	Description	Function
	New	Opens as dialog box to define an object
	Edit	Opens a dialog box to modify an object
	Pick	Graphic selection
	Import	Imports from current selection
	Library	Opens a collection of stored data
	Help	Opens the help function
	Apply	Applies changes without closing the dialog box
	Settings	Opens a dialog box for detailed settings
	Units and Decimal Places	Settings for units and decimal places → chapter 10.4.3, page 193
	Standard	Restores default settings
	Set as default	Stores the current settings as default
	Fonts	Option to define fonts and font sizes
	Info	Displays information to an object
	Transfer selection	Transfers selected items from one list to another
	Transfer all	Transfers all items from one list to another
	Save	Stores a user-defined entry
	Import	Imports a stored entry
	Select	Selects certain resp. all objects
	Deselect	Deletes resp. deselects all entries

Table 4.4: Default buttons

4.3.8 Keyboard Functions

In spite of graphical interfaces, it may be helpful for experienced users to call up frequently used functions by keystrokes. Here is a list of all keyboard functions:

[F1]	Help
[F2]	Next table
[F3]	Previous table
[F5]	Start Calculation
[F7]	Selection function in tables
[F8]	Displays the entire structure – <i>Show all</i>
[F9]	Calculator
[F10]	Menu Bar
[F12]	Saves the structure under a different file name
[Alt]	Menu Bar
[Ctrl+2]	Copies a row of the table to the next row
[Ctrl+A]	Redo
[Ctrl+C]	Copies to the clipboard
[Ctrl+F]	Searches within the table
[Ctrl+G]	Generates entries in the table
[Ctrl+H]	Finds entries in the table and replaces them
[Ctrl+I]	Inserts rows in the table
[Ctrl+L]	Goes to a specific row number in the table
[Ctrl+N]	Creates a new structure
[Ctrl+O]	Opens a structure
[Ctrl+P]	Prints the picture to the printer, printout report or clipboard
[Ctrl+R]	Deletes a row in the table
[Ctrl+S]	Saves the structure
[Ctrl+U]	Deselects in the table
[Ctrl+V]	Inserts from clipboard
[Ctrl+X]	Cuts items in the table
[Ctrl+Y]	Deletes the contents of a row in the table
[Ctrl+Z]	<i>Undo</i> function
[+] [-] NumPad	Zoom functions

Table 4.5: Keyboard functions

4.3.9 Context Menus

For most elements, a context menu can be activated by a right mouse click. It contains useful items for the selected object.

Context menus can be used in the SHAPE graphics, navigator and tables.

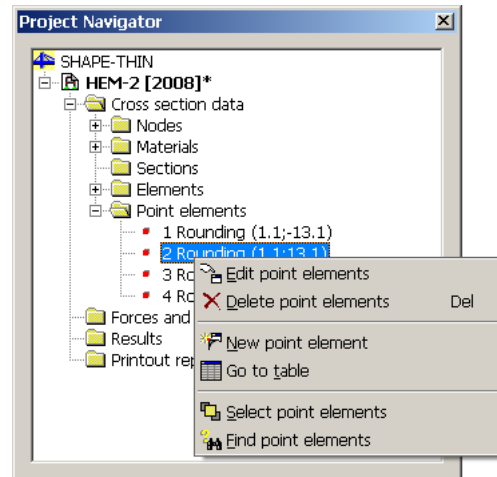

Figure 4.16: Point elements context menu in the navigator

4.4 File Management

SHAPE includes an administration of the cross-sections called the *Project Manager* which helps to organize all user-defined sections. It allows for the management of several sections under one project.

4.4.1 Project Manager

The Project Manager can be called with the appropriate button in the default toolbar or via menu **File** → **Project Manager**.



Figure 4.17: Button *Project Manager* in the toolbar

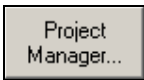

The *General Data* dialog box also offers a button to directly access the Project Manager.

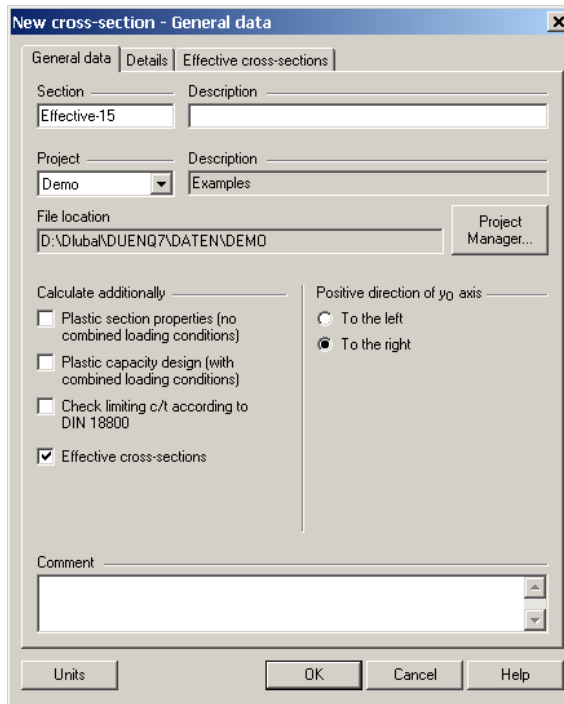

Figure 4.18: Dialog box *General Data*

After calling up the Project Manager, a three-part window appears. This window has its own menu and its own toolbar.

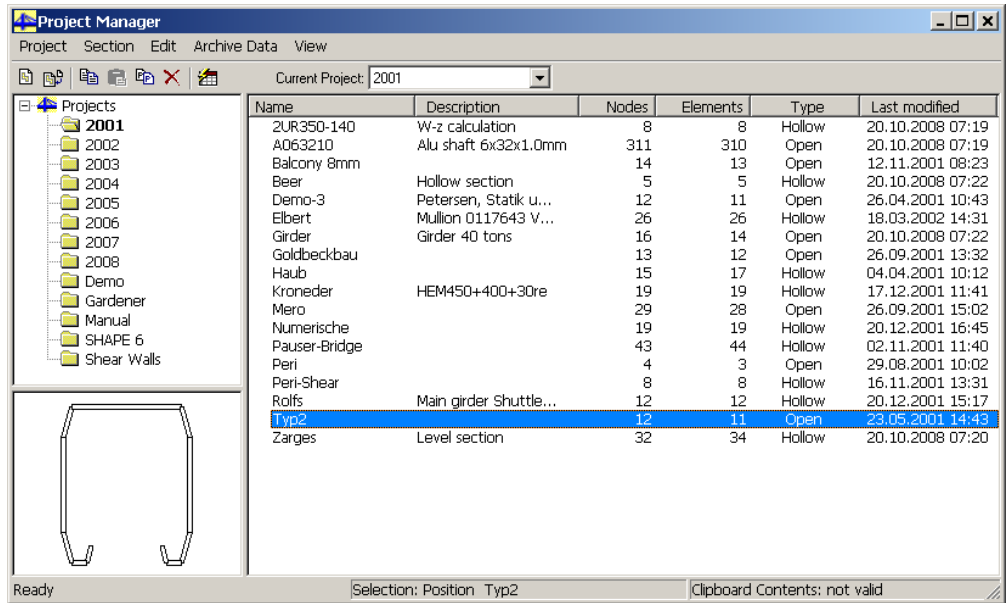

Figure 4.19: Project Manager

Project Navigator

A navigator with a list of all existing projects is displayed in the top left part. The current project is set bold. A different project can be selected as 'current' by double-clicking it or via the list *Current Project* in the toolbar. To the right, a listing is shown with all sections of the selected project.

Table of Sections

The sections are listed with their names and descriptions, numbers of nodes and lines as well as the types and the dates of the last modification.

Sections Preview

When one of the section names is selected, the corresponding illustration of this section appears in the lower left part of the Project Manager.

4.4.1.1 Projects

Create New Project

A new project is created via the

- menu **Project** → **New**
- button [New Project] in the toolbar

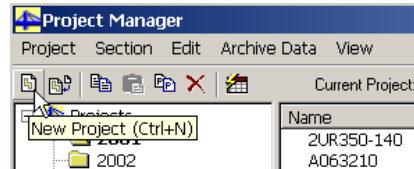

Figure 4.20: Button *New Project*

Browse...

In the following dialog box, it is necessary to provide the *Project Name* and *Folder*. The [Browse] button is used to locate the index path. Also a *Description* can be added as short specification of the project.

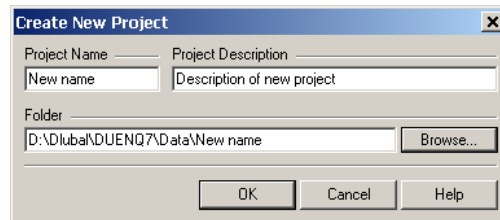

Figure 4.21: Dialog box *Create New Project*

[OK] will create a new folder with the project name on the local or network drive.

The *Description* of the project is shown in the headline of the printout report and has no further relevance.

Connect Existing Folder

The function can be called up via the

- menu **Project** → **Connect Folder**
- button [Connect Folder] in the toolbar.

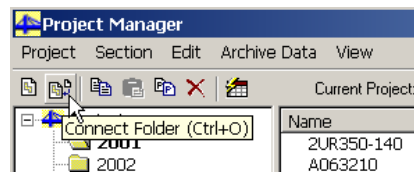

Figure 4.22: Button *Connect Folder*

It is irrelevant on which local or network drive the folder is located that is to be connected. It will simply be included, but left at its location – similar to creating a shortcut on the desktop. All project information is saved in the **DU_PRO.DLP** file which is located in the **..\Dlubal\Stammdat** folder.

Browse...

The *Name* and *Description* for the project is to be entered. Then set the path for the *Folder* to be connected with the [Browse] button.

Disconnect Project Folder

This function can be called up via the

- menu **Project** → **Disconnect** (a project must have been selected)
- context menu of a project.

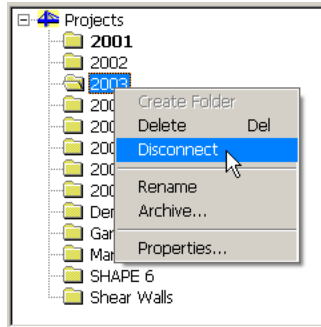

Figure 4.23: Context menu *Project*

Connected projects in the Project Manager are removed from the internal management, but the folder and its contained data will not be deleted from the hard drive.

Delete Project



You can delete a project via the

- menu **Edit** → **Delete** (the project must have been selected)
- button [Delete] in the toolbar
- context menu of a project in the navigator.

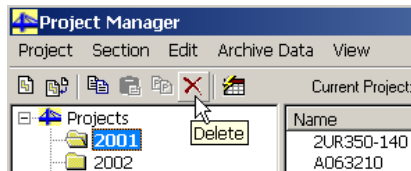

Figure 4.24: Button *Delete Project*



The folder on the hard disk will be deleted together with its contents. If the folder contains other files apart from SHAPE files, they will be deleted as well.

Change Project Description

This function can be called up via the

- menu **Project** → **Properties** (the project must be selected)
- context menu of a project in the navigator.

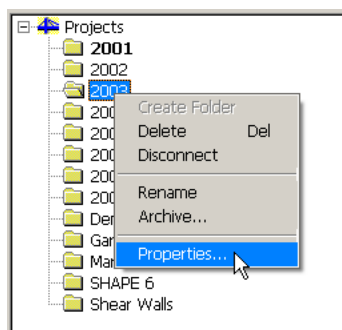

Figure 4.25: Context menu *Project*

The *Description* of the project can be changed in a dialog box. Apart from this, the location of the project on the hard disk is shown.

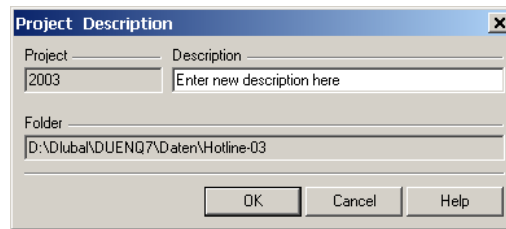

Figure 4.26: Dialog box *Project Description*

If the project is to be renamed, you can use the

- menu **Edit** → **Rename** (the project must be selected)
- context menu of the project in the navigator.

4.4.1.2 Sections

Open Section

An existing cross-section can be opened via

- double-clicking
- menu **Position** → **Open** (a section must have been selected)
- its context menu.

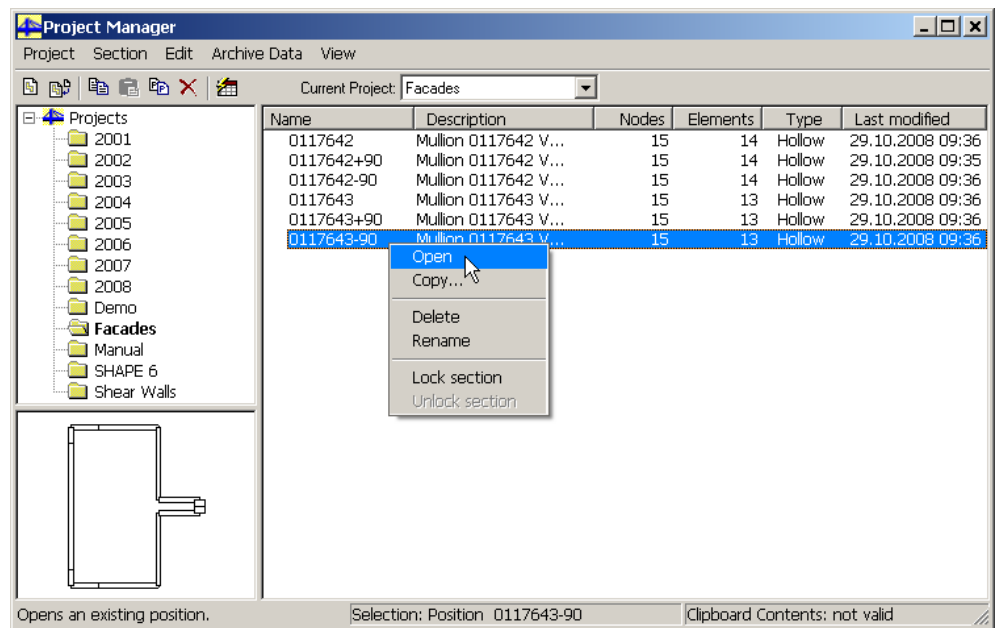

Figure 4.27: Context menu *Section*

Move and Copy Section

A section can be moved or copied via

- menu **Section** → **Copy** (the section must have been selected)
- the context menu of the section
- drag & drop.

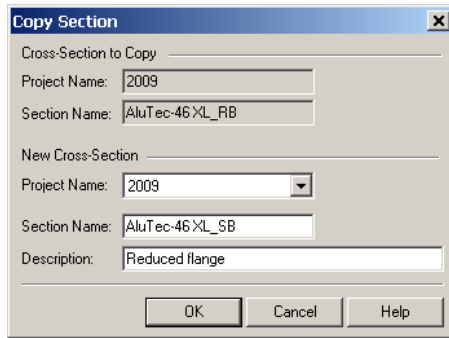

Figure 4.28: Dialog box *Copy Section*

In this dialog box, the target project as well as the name and the description are to be entered for the copy of the section.

Rename Section

It is possible to rename a cross-section via the

- menu **Edit** → **Rename** (the section must have been selected)
- context menu of the section.

If the description of the section is to be changed, the section has to be opened first. Then its description can be modified in the *General Data* dialog box (cf Figure 4.33, page 53).

Delete Section

A structure can be deleted via the

- menu **Edit** → **Delete** (the section must have been selected)
- button [Delete] in the toolbar
- context menu of the section.

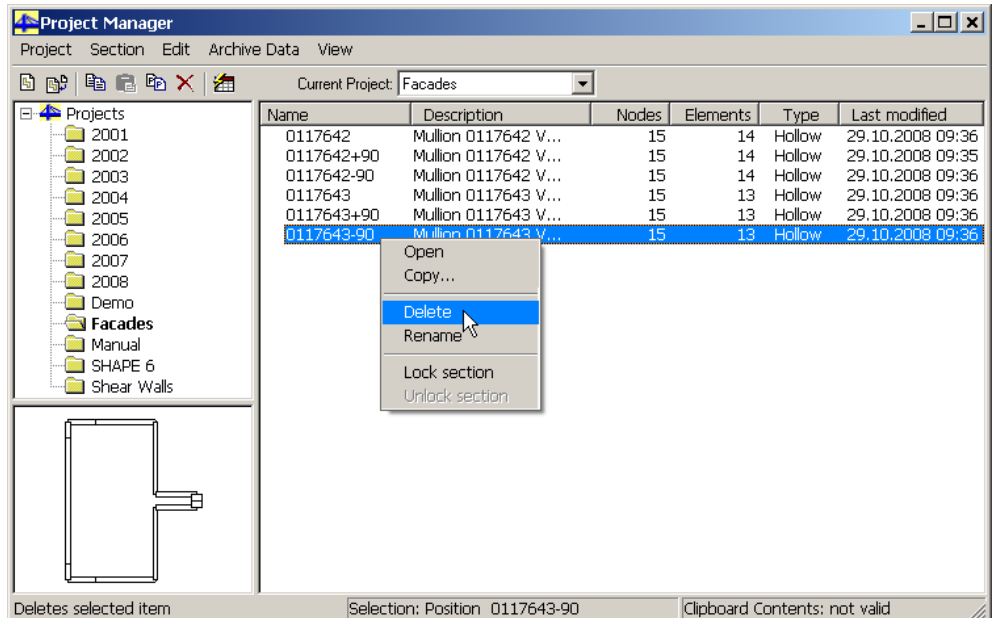

Figure 4.29: Context menu *Section*

4.4.1.3 Data Archiving

Archive Data

Selected sections or an entire project folder can be saved in a compressed backup file. The original sections remain in their folders.

It is possible to archive selected sections or a folder via the

- menu **Archive Data** → **Make Archive** (select sections or project before)
- context menu of the project.

Before archiving all data, it can be decided whether the results and printout reports are to be excluded from the backup file in order to save space.

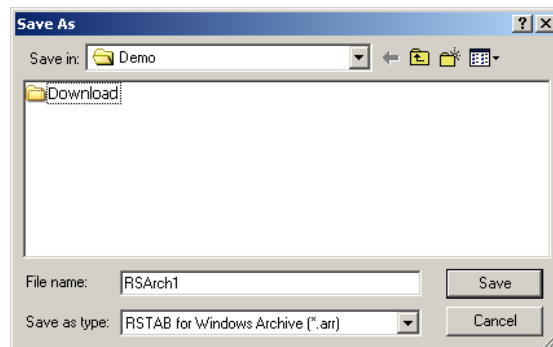

Figure 4.30: Dialog box *Save as*

When the *Name* and *Folder* of the archive file have been defined, the *.arr archive file can be created.

Dearchive Data

This function decompresses a SHAPE archive file via the menu

Archive Data → **Extract from Archive**.

When the archive file has been selected, its contents are shown:

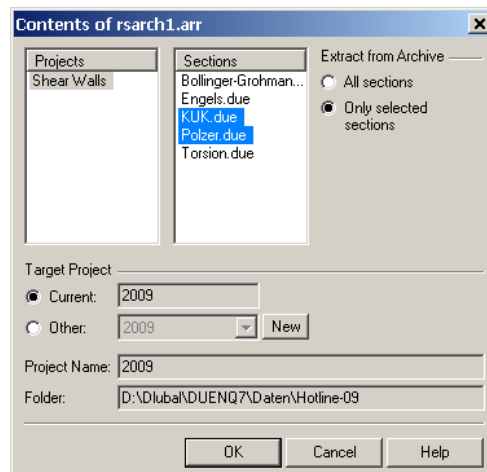

Figure 4.31: Dialog box *Contents of rsarch1.arr*

New

The files that are to be restored can be selected in section *Sections*. The chosen sections can be restored to the *Current* or an *Other Target Project* which can be picked from the list. It is also possible to create a [New] project in a separate dialog box.

4.4.1.4 Appearance

It is possible to adjust the listing of the sections in the project according to your needs. As usual with Windows applications, the list will be sorted ascending or descending by clicking on the column title.

All viewing functions are accessible in menu **View** of the Project Manager.

4.4.2 Create New Section

A new cross-section can be created via the

- menu **File** → **New**
- button [New Cross-Section] in the toolbar
- menu **Position** → **New** in the Project Manager



Figure 4.32: Button *New cross-section*

The dialog box *New cross-section - General data* is opened.

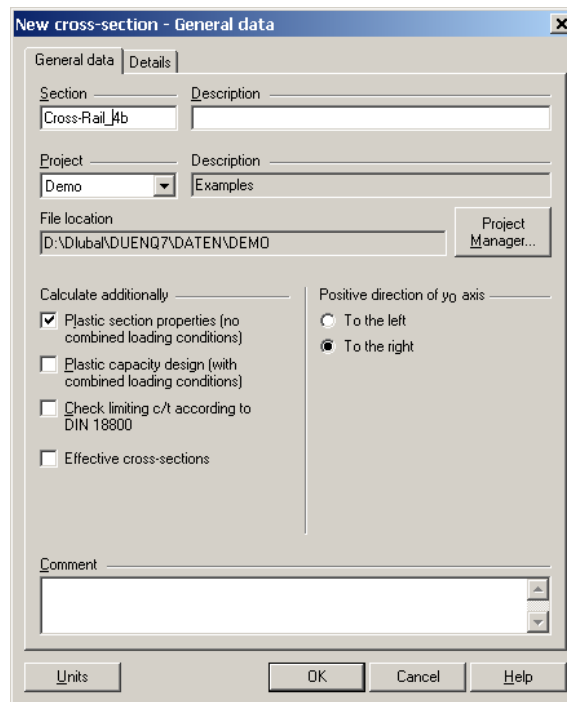

Figure 4.33: Dialog box *New cross-section - General data*, *General data* tab

At a later date, it is possible to modify the general data of a section via the

- menu **Edit** → **Section Properties** → **General data**
- context menu in the navigator.

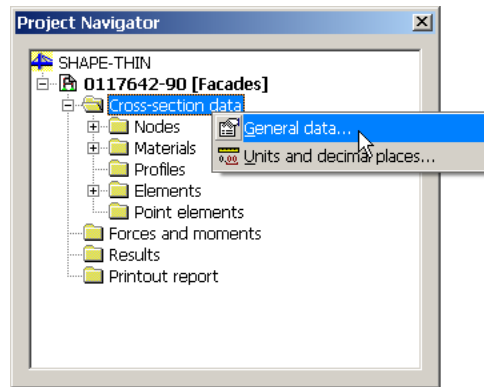

Figure 4.34: Context menu of the section

This dialog box consists of several tabs. Some of these are only available when the corresponding check box is activated among the options *Calculate additionally* of the first tab *General*. The different registers are described in the following chapters.

4.4.2.1 General Data

Section

In the *Section* input field, the name of the cross-section can be specified. This will be the file name of the section, too. The *Description* can be used for more detailed information. It will be shown in the headline of the printout report but has no further relevance.

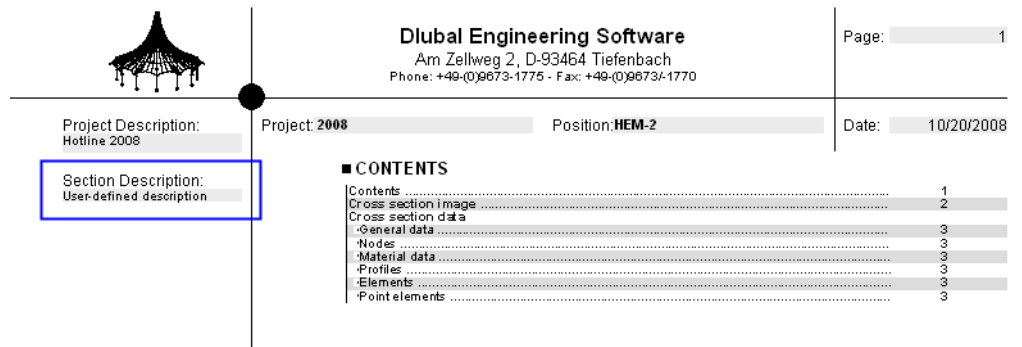
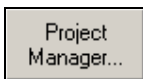

Figure 4.35: Section description in the Printout Report



Project

The project folder of the new section can be selected from the list of projects. The default folder is the current project which can be changed in the Project Manager (cf chapter 4.4.1, page 47). You can call up the [Project Manager] by clicking on the corresponding button.

The *Description* of the project and the *File location* are displayed for information, too.

Calculate Additionally

In this part of the dialog box, specific settings can be defined for the analysis of the section.

Plastic Section Properties

If this check box is activated, SHAPE determines the plastic section characteristics without considering the interaction of the internal forces. After the analysis, the plastic forces N_{pl} , V_{pl} and moments M_{pl} will be listed in the results table 2.1, together with the plastic section moduli Z and the plastic shear areas A_{pl} .

Plastic Capacity Design

The plastic capacity design is disabled by default as it is time-consuming and not required in most cases. If this check box is set active, the additional tab *Plastic calculation* appears. There, the settings for the discretization can be made (see below). Please note that internal forces are to be defined in table 1.7 so that the plastic capacity design can be carried out.

Check Limiting c/t

If the c/t zones of the elements are to be checked according to DIN 18800, this check box is to be activated. Then the additional tab *c/t Check* is available to specify the detail settings (see below).

Effective Cross-Sections

SHAPE is able to determine the effective cross-section widths according to EN 1993-1 and DIN 18800. If this option is set active, the above-mentioned three check-boxes will be disabled. In the additional tab *Effective cross-sections*, the details can be set (see below). To calculate the effective cross-section widths, internal forces are to be defined in table 1.7.

Positive Direction of the y_0 Axis

This dialog section controls the direction of the global coordinate axis y_0 (absolute zero) which can be defined to the *left* or to the *right* (default).



Independent of the selected direction, SHAPE assumes the cross-sectional areas positively according to the following convention.

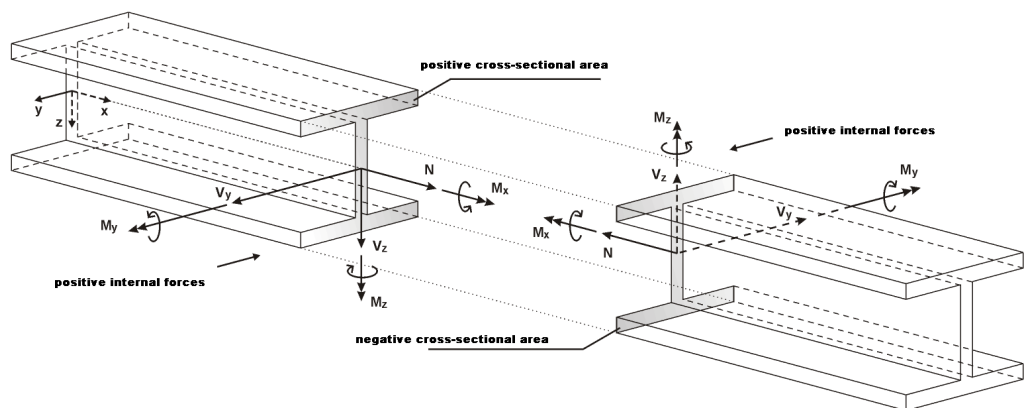

Figure 4.36: Sign convention for internal forces

The *positive direction of the y axis* only represents the view on the illustrated positive cross-sectional area against or in direction of the positive axis x of the member.

Comments

A text can be used to describe the section which will also appear in the printout report.

The [Units] button calls up the dialog of the same name. It is described in chapter 10.4.3 on page 193.

Units

4.4.2.2 Details

In the *Details* tab, further settings allow for a user-definable tuning of the calculation parameters.

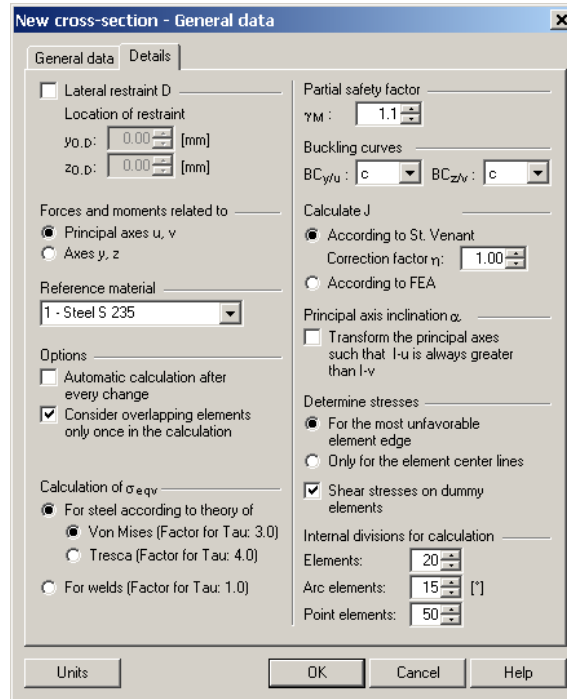

Figure 4.37: Dialog box *New cross-section - General data*, *Details* tab

Lateral Restraint D

Pick

In this part of the dialog box, you can define whether or not a laterally supported rotation axis is effective. The *Location of restraint* can be entered by its $y_{0,D}$ and $z_{0,D}$ coordinates or picked in the graphics.

Thus, a torsionally loaded section does not rotate freely about its shear center M but rather about the defined point of support D . This has an effect on the warping constant I_{ω} , the reduction factor λ , the normalized warping constants and the stresses $\sigma_{M\omega}$ and τ_{M_s} .

Forces and Moments Related to

You can specify whether the forces and moments that are entered in table 1.7 refer to the *Principal axes* u, v of the cross-section or to the *Axes* y, z that are parallel to the global input axes y_0 and z_0 . With this option, is not necessary to transform the internal forces when defining them in the input table.

Reference Material

With composite sections, it is recommended to check the type of material which is set as *Reference material*. The idealized section properties will be determined in proportion to the various moduli of elasticity relating to this material. If desired, a different material can be chosen from the list.

Options

The *Automatic calculation after every change* is disabled by default but can be activated via this check box.

It is recommended to *Consider overlapping elements only once in the calculation* so that the section properties are determined correctly. For example, overlapping elements can be seen in the corners of sections. For the analysis, point elements with the status "Remove" will be applied internally there. This function does not apply to arcs, however.

If elements with different materials overlap, the dialog box *Overlapping Elements* appears. There, the material can be selected which is to be assigned to the overlapping area.

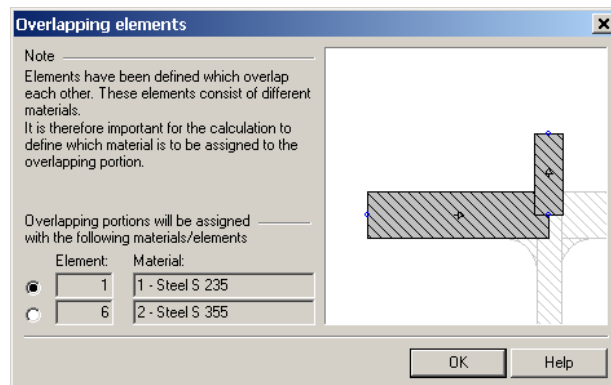

Figure 4.38: Dialog box *Overlapping Elements*

Calculation of Sigma-eqv

There are different approaches available to calculate the equivalent stresses.

For *steel* sections, σ_{eqv} can be determined according to the yield criteria of

- VON MISES: $\sigma_{eqv} = \sqrt{(\sum \sigma_x)^2 + 3 \cdot (\sum \tau)^2}$
- TRESCA: $\sigma_{eqv} = \sqrt{(\sum \sigma_x)^2 + 4 \cdot (\sum \tau)^2}$

For *welds*, σ_{eqv} can be determined according to the following equation:

$$\sigma_{eqv} = \sqrt{(\sum \sigma_x)^2 + (\sum \tau)^2}$$

Equation 4.1



Please note that SHAPE covers the planar state of stresses. Thus, the shear stresses of longitudinal seams of welds $\tau_{||}$ have additionally to be taken into account for the weld design.

The factor that controls the shear stresses τ in those equations also has an effect on the plastic capacity design of the section.

Partial Safety Factor

This factor describes the safety factor of the material resistance. Thus, the index *M* is used. The factor γ_M is used to reduce the characteristic values of the material yield strength f_{yk} for e.g. the limiting axial and bending stresses $\sigma_{R,d}$ and the limiting shear stress $\tau_{R,d}$.

Buckling Curves

For buckling analyses, every section has to be classified to specific buckling curves with respect to the principal axes *y* and *z* respectively *u* and *v* (cf DIN 18 800 Part 2, Table 5 or Eurocode 3, Table 6.2). The buckling curves $BC_{y/u}$ and $BC_{z/v}$ control e.g. the imperfection factor α as described in EN 1993-1-1: 2005, Table 6.1:

Buckling Curve	a ₀	a	b	c	d
α	0.13	0.21	0.34	0.49	0.78

Table 4.6: EN 1993-1-1: 2005 – Imperfection factor α subject to buckling curves



Generally, the buckling curves mainly depend on the shape of the section. As the program cannot allocate the buckling curves automatically for user-defined sections, $BC_{y/u}$ and $BC_{z/v}$ are to be specified manually via the two list boxes.

J Calculation

If a rolled section is made up of rectangular elements, the St. Venant torsional constant (2nd moment of area) J can be multiplied with a *correction factor* η that accounts for the corner radii. Depending on the shape of the section, this factor lies between 0.99 and 1.30.

Section	L	C	T	I
η	0,99	1,12	1,12	1,30

Figure 4.39: Correction factor η

Alternatively, a *FEA calculation* can be carried out to determine J .

Principal Axis Inclination α

For sections that are wider than high, the major axis u may be in horizontal position, which means that the principal moments of inertia are swapped with regard to their sizes. With the option to *Transform the principal axes such that I_u is always greater than I_v* , the axis u always represents the major axis, independent of the position of the section.

This option is not recommended if this section is used in RSTAB to model tapered members. A change of the principal axes within the members might occur.

Determine Stresses

In this part of the dialog box, it is possible to determine if the stresses are to be calculated at the *most unfavorable element edges* (default) or only at the *element center lines*. The following figure shows the stress points for those two options.

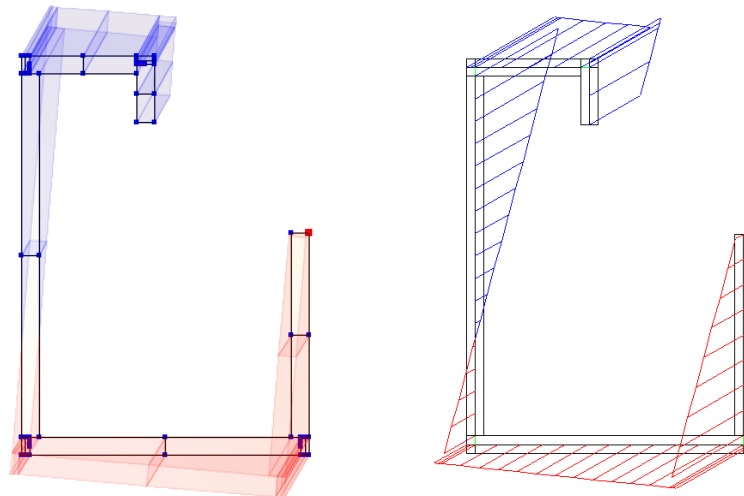

Figure 4.40: Stress points at most unfavorable edges (left) and only at element center lines (right)

Even if the stresses are calculated at the most unfavorable edges, they will nevertheless be drawn at the element center lines. For a realistic distribution over the section, the panel has to be activated in order to display the isosurfaces (cf Figure 8.4, page 140).

Internal Divisions for Calculation

For the analysis, an internal division of the objects is used. In this final part of the dialog box, detailed settings can be made for *Elements*, *Arc elements* and *Point elements*.

Please note that the division for arc elements is not a numerical sub-division as it is applied for elements and point elements. Instead, the division is made via equal angles whose size can be entered in degrees [°].

4.4.2.3 Plastic Design

The *Plastic design* tab allows for specific settings to control the plastic analysis.

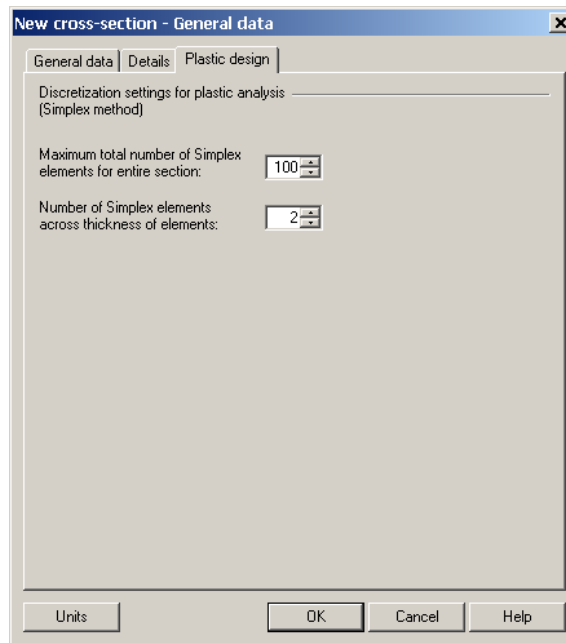

Figure 4.41: Dialog box *New cross-section - General data, Plastic design* tab

There are two options available to control the discretization by so-called Simplex elements:

- The *Maximum total number of Simplex elements* represents the overall limit of the sub-elements that are to be created for the entire section (default: 100).
- The *Number of Simplex elements across the thickness of the elements* controls the distribution of the Simplex elements on the elements of the section (default: 2).



In most cases, the default settings represent a practical compromise between accuracy and calculation speed. The more Simplex elements are to be processed, the more time the analysis will take.

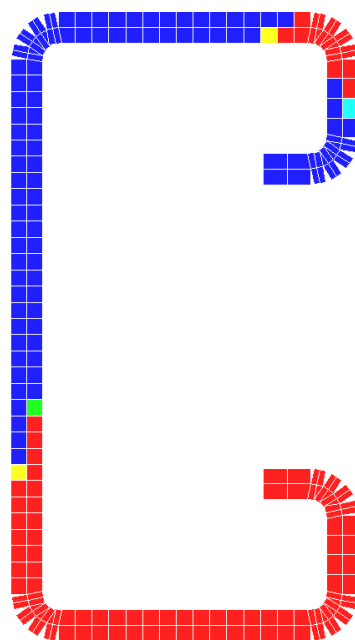

Figure 4.42: Simplex elements

To reduce the calculation time for the plastic design, the following notes may be useful:

- Reduce the number of *Load Cases* and *Locations* x in table 1.7 *Forces and Moments*. Thus, the really required design can be carried out exclusively.
- Two Simplex elements across the element thicknesses are sufficient in most cases for thin-walled sections.
- If there are only short arc elements at the corners of the section, the internal division of the arcs can be increased to e.g. 30° for a smooth distribution of Simplex elements on the overall cross-section. For details, see the previous chapter on page 58.

4.4.2.4 c/t Zones

This tab controls the settings for checking the width-to-thickness ratios c/t according to DIN 18800.

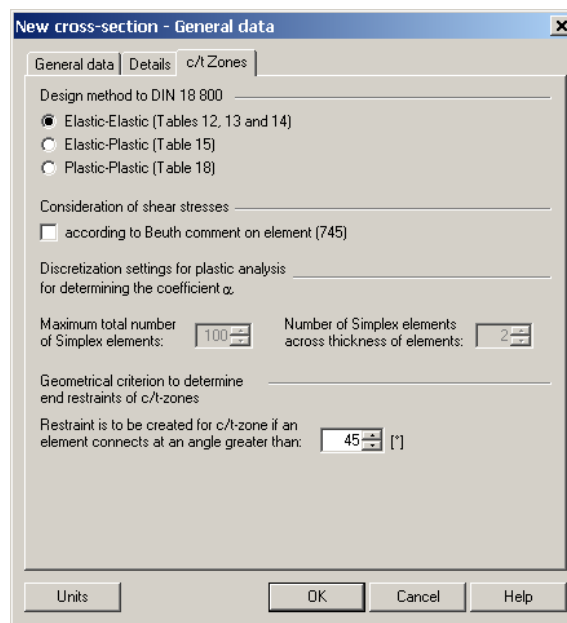

Figure 4.43: Dialog box *New cross-section - General data*, *c/t Zones* tab

Design Method

There are three options available to check the c/t ratios which depend on the design method according to DIN 18800 Part 1:

- Elastic-Elastic (Tables 12, 13 and 14)
- Elastic-Plastic (Table 15)
- Plastic-Plastic (Table 18)

If the *Elastic-Elastic* design method has been chosen, the *Consideration of the shear stresses* can optionally be made according to the BEUTH comment on element (745), cf [5].

For the *Elastic-Plastic* or *Plastic-Plastic* design methods, the *Discretization settings to determine the coefficient Alpha* allow for a user-defined arrangement of the so-called Simplex elements on the section. There are two options available:

- The *Maximum total number of Simplex elements* represents the overall limit of the elements that are to be created for the entire section (default: 100).
- The *Number of Simplex elements across the thickness of the elements* controls the distribution of the Simplex elements on the elements of the section (default: 2).

Geometrical Criterion for Restraints

If several elements are connected in a straight line, SHAPE automatically recognizes the continuous lengths (inclusive of dummy elements) in order to determine the c/t ratio of this sectional part. An end support will be assumed where another element is connected at an angle greater than 45° by default. In the input field *End restraint of a c/t zone*, a different angle can be specified.

If the element thicknesses vary within a c/t zone, the thickness of the thinnest element is assumed for this zone. If there is a dummy element between two ordinary elements that have the same thickness t , a continuous c/t zone is created from all three elements by applying the thickness t . This implies that there are no end restraints for dummy elements.

c/t zones that have been detected automatically can be modified via the menu

Extras → **Edit c/t zone restraints.**

The dialog box *c/t Zone Restraint on/off* appears as seen in Figure 4.45 on page 62.



SHAPE can only check the width-to-thickness ratios if internal forces have been defined for the section. With all three design methods, the maximum c/t values depend on the stress distribution in the section due to the current forces and moments.

4.4.2.5 Effective Cross-Sections

In the *Effective cross-sections* tab, specific settings can be made for the analysis of the effective cross-section according to DIN 18800 and EN 1993-1.

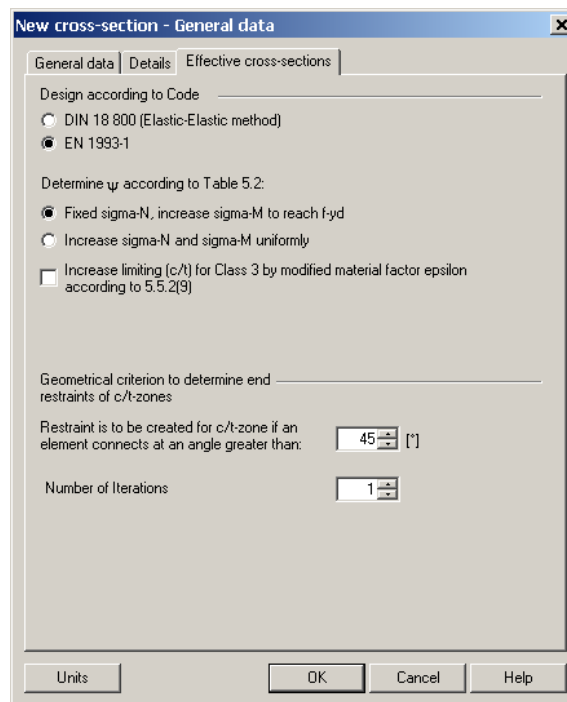

Figure 4.44: Dialog box *New cross-section - General data*, *Effective cross-sections* tab

Design according to Code

There are two selection fields available in the upper part of this dialog box to determine the standard according to which the effective widths are to be calculated:

- DIN 18800 (design method Elastic-Elastic)
- EN 1993-1

In DIN 18800, the design details are described in Part 2, Chapter 7. As for Eurocode 3, the description of the effective widths is contained in EN 1993-1-5, Chapter 4.

Please note that the analysis of the effective cross-section according to DIN 18800 is only applicable for rectangular hollow sections, doubly or singly symmetric I-shape sections, U-, C- and Z-sections, top-hat sections and corrugated hollow sections.

Determine ψ according to Table 5.2

The factor ψ describes the stress ratio of the boundary stresses for each c/t zone. These stresses are determined from the normal stresses. This factor is required to analyze width-to-thickness ratios according to EN 1993-1-1, Table 5.2.

If there are stresses due to compression and bending within the cross-section, the ratio of the boundary stresses can be determined in two ways: Either only the flexural stress component σ_M is increased in order to reach the yield strength f_{ydr} , or both stress components σ_N and σ_M are uniformly increased until the yield strength is reached.

It is possible to *Increase the limiting c/t proportions for Class 3 cross-sections* according to EN 1993-1-1, 5.5.2 (9) by taking into account an increased material factor ϵ . Thus, Class 4 sections can be treated as Class 3 sections.

Geometrical Criterion for Restraints

If several elements (inclusive of dummy elements) are connected in a straight line, SHAPE automatically recognizes the continuous lengths in order to determine the c/t ratio of this sectional part. An end support will be assumed where another element is connected at an angle greater than 45° by default. In the input field *End restraint of a c/t zone*, a different angle can be specified.

If the element thicknesses vary within a c/t zone, the thickness of the thinnest element is assumed for this zone. If there is a dummy element between two ordinary elements that have the same thickness t , a continuous c/t zone is created from all three elements by applying the thickness t . This implies that there are no end restraints for dummy elements.

c/t zones that have been detected automatically can be modified via the menu

Extras → **Edit c/t zone restraints**.

The dialog box *c/t Zone Restraint on/off* appears.



Figure 4.45: Dialog box *c/t Restraint on/off*

After having selected the *Node* in the graphics, you can *Remove* or *Set* an end restraint there.



SHAPE can only analyze the effective cross-section widths if internal forces have been defined for the section.

Number of Iterations

In the last input field of this tab, the number of iterations can be defined. The more iterations, the longer the analysis will take but the more precise the calculation will be. In general, though, the default setting of 1 iteration provides suitable results.

4.4.3 Network Management

If several persons in the office use the same stock of cross-sections, the sections can be organized by the project manager. It is necessary, however, that the sections are stored in a folder that is accessible on the network.

Connect the network folder to your internal project management. This is described in chapter 4.4.1.1 on page 48. After that, the sections of this folder can be accessed by the Project Manager, i.e. opened, modified and made write protected.

If a user works on a section that another user wants to open, a warning will appear. This section can then be opened as a copy.

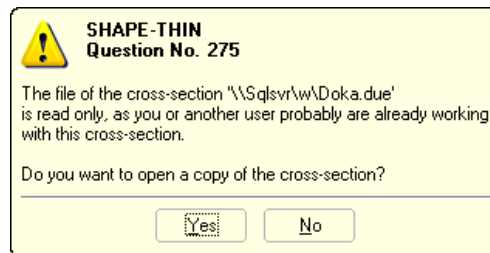

Figure 4.46 Question when opening a read-only file



An automatic merging of the changes is not possible.

The data for the projects registered in the Project Manager are stored in the **DU_PRO.DLP** file. This is an ASCII file which is located in the folder *..\Program Files\Dlubal\Stammdat* by default.

To avoid connecting the folders by projects one by one, you can copy the **DU_PRO.DLP** file to a different computer. The file can also be modified by means of an editor. This facilitates the task to import all relevant project folders into the Project Manager, especially after new installations.

Before pasting the file **DU_PRO.DLP**, you should save the existing file.

5. Section Data

A cross-section needs to be opened before the input of sectional data can start. For more details, see chapter 4.4.2 on page 53.

SHAPE offers several ways to enter data. The objects can be specified in a **dialog box**, a **table** and often also directly in the **graphics**.

The dialog boxes and the graphic input can be called up via the

- items in menu *Insert*
- buttons in the toolbar *Input*
- context menus of the cross-section data objects in the navigator.

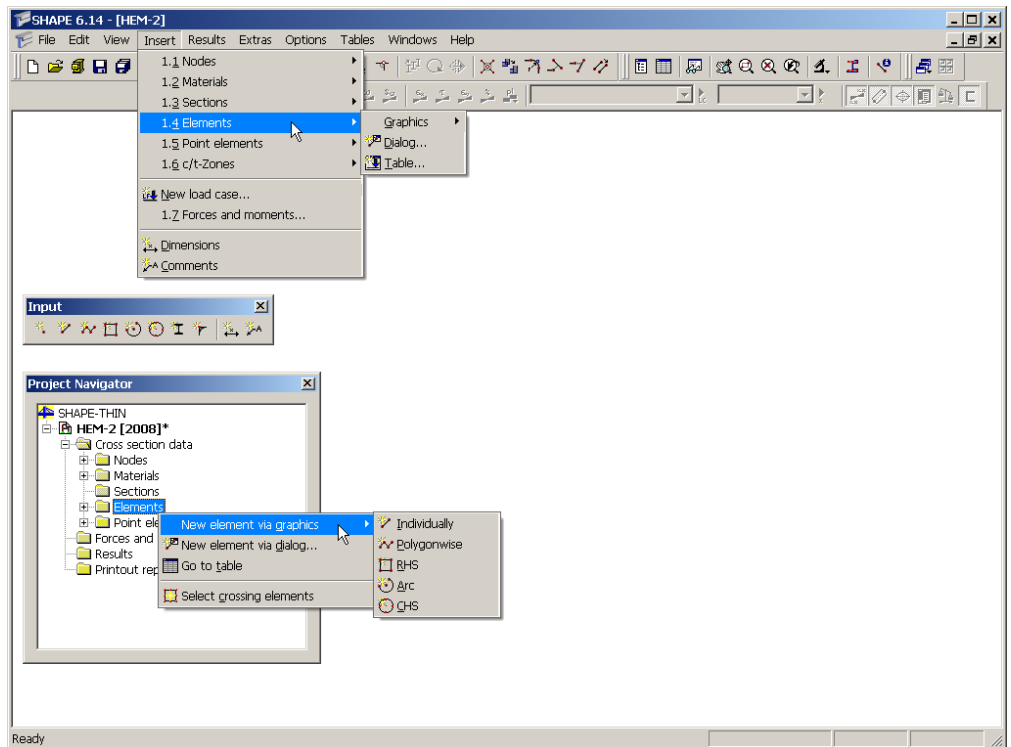

Figure 5.1: Input options via **menu**, **toolbar** and navigator **context menu**

If you want to change an already defined object, you can do this in a **dialog box** or in a **table**.

The editing dialog boxes are called up via the

- items in menu **Edit** → **Section Properties**
- context menus or double-clicking on the objects the graphics
- context menus or double-clicking on the objects in the navigator.

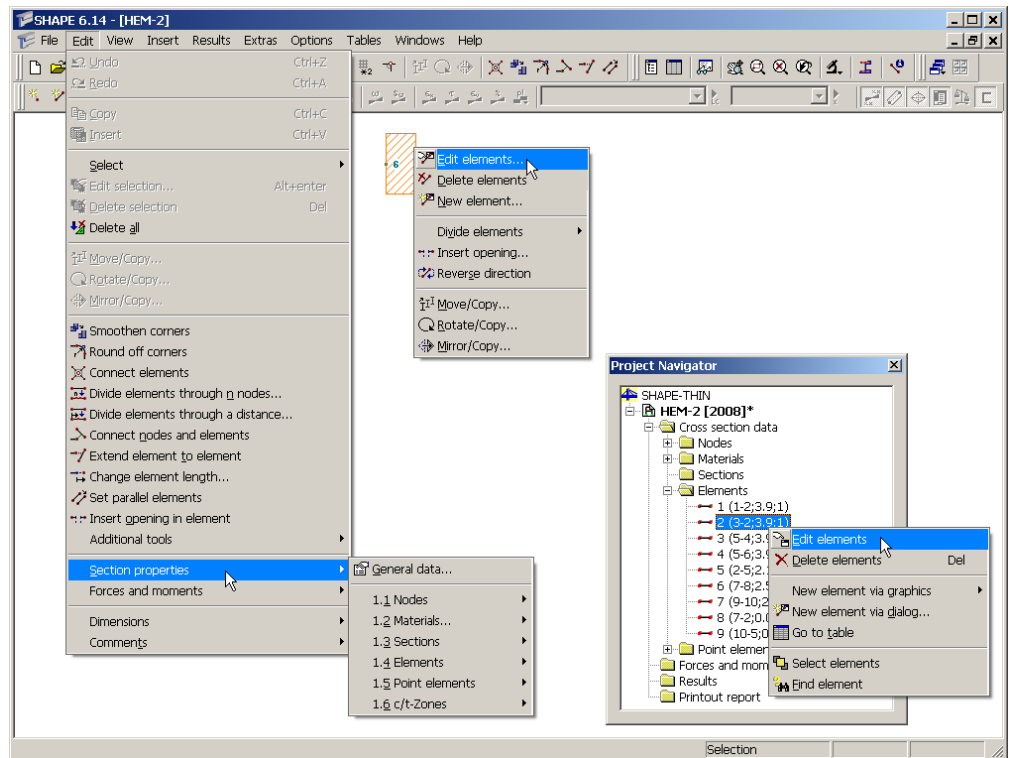

Figure 5.2: Opening the editing dialog boxes via menu and context menus



The input and modifications within the graphics are immediately shown in the tables, and vice versa. If the tables are not shown, they can be switched on via menu **View** → **Tables** or the corresponding button as seen to the left.

Tables

1.1 Nodes

Node No.	A		D		F		G
	Coordinate system	Ref.-Node	Node coordinates y ₀ [mm]	z ₀ [mm]	Principal axis coordinates y [mm]	z [mm]	
1	Cartesian	0	-155.0	-150.5	-155.0	-150.5	
2	Cartesian	0	0.0	-150.5	0.0	-150.5	
3	Cartesian	0	155.0	-150.5	155.0	-150.5	
4	Cartesian	0	-155.0	150.5	-155.0	150.5	
5	Cartesian	0	0.0	150.5	0.0	150.5	
6	Cartesian	0	155.0	150.5	155.0	150.5	
7	Cartesian	0	0.0	-170.0	0.0	-170.0	
8	Cartesian	0	0.0	-220.0	0.0	-220.0	
9	Cartesian	0	0.0	220.0	0.0	220.0	
10	Cartesian	0	0.0	170.0	0.0	170.0	

Nodes | Materials | Sections | Elements | Point elements | Forces and moments | Section properties

Define the coordinate system or press F7 Pick!

Figure 5.3: Input table 1.1 Nodes

By working through the individual tabs, a smooth and flawless workflow for the input is ensured. This allows also for a good overview over the record. The data can be also be quickly edited or imported from spreadsheets.

Comments can be added in every dialog box or table to describe the object in more detail.

5.1 Nodes

General Description

Nodes are used to describe the geometry of the section. They are essential for elements and sections. Every node is defined by its coordinates (y_0, z_0). The coordinates usually refer to the origin of the coordinate system (0/0), but it is also possible to define the reference to a specific node.

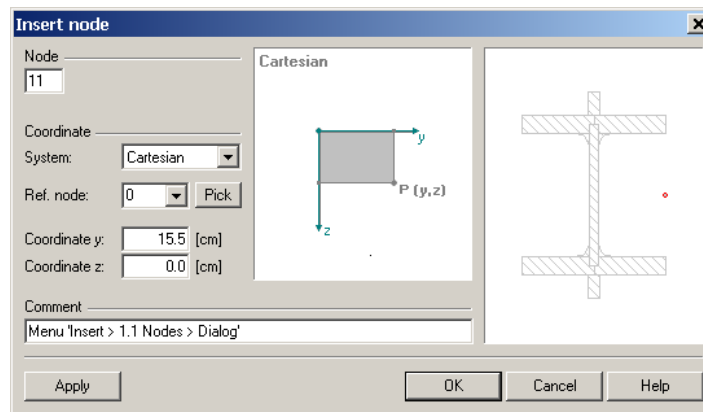
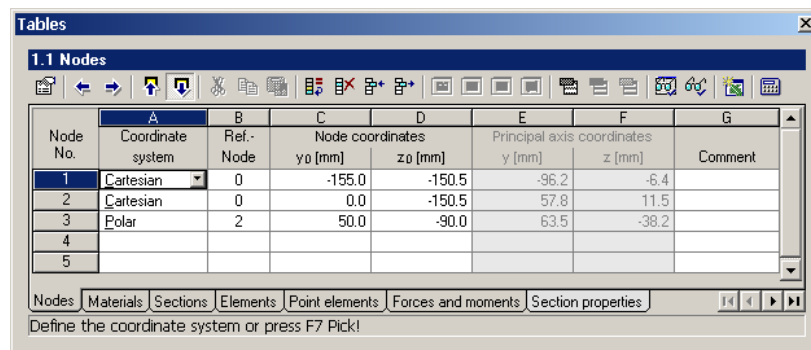

Figure 5.4: Dialog box *Insert node*



Node No.	Coordinate system	Ref.-Node	Node coordinates		Principal axis coordinates		Comment
			y_0 [mm]	z_0 [mm]	y [mm]	z [mm]	
1	Cartesian	0	-155.0	-150.5	-96.2	-6.4	
2	Cartesian	0	0.0	-150.5	57.8	11.5	
3	Polar	2	50.0	-90.0	63.5	-38.2	
4							
5							

Figure 5.5: Table 1.1 *Nodes*

The node number is assigned automatically. If desired, a different number can be entered in the *Node* input field. The order of the numbering has no significance, gaps are permitted as well. 'Free' nodes (i.e. without connected elements) are irrelevant for the analysis.

Coordinate System

The coordinates of a node always refer to a coordinate system which describes the position of the node. According to the geometry of the section, you can choose between two coordinate systems.

Cartesian

The axes y_0 and z_0 describe a translational expansion (linear). All directions of the coordinates are on an equal footing. Usually, the nodes are defined in this coordinate system.

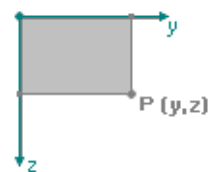

Figure 5.6: Cartesian coordinate system

Polar

In the circular coordinate system, the position of a node is described by the radius R which defines the distance to the origin, and the angle φ .

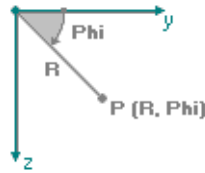

Figure 5.7: Polar coordinate system

The polar coordinate system is orientated clockwise.

To facilitate the input, the section might be arranged with reference to the origin so that the y_0 and z_0 axes correspond with the main directions of the sectional elements.

If the floating dialog box *New Node* is used for the graphic input, the nodes can be set directly by mouse clicks. The nodes usually snap on the grid points which are orientated on the global coordinate system.

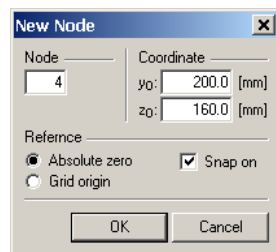

Figure 5.8: Floating dialog box *New Node*

When modifying the coordinate system afterwards, the nodal coordinates can be automatically converted into the new system.

Reference Node

In general, the coordinates of a node refer to the origin of the coordinate system y_0/z_0 . In this case, the node (0/0) does not need to be defined explicitly as SHAPE recognizes the absolute zero automatically.

Any other node can also serve as reference node. Even a node with a higher number can be used as reference node. The reference to a different node is e.g. useful when you want to define a new node at a certain distance from a known location.

In the *Insert Node* dialog box (cf Figure 5.4), the node can be entered directly, selected from the list or selected in the graphics via [Pick].

Pick

Node Coordinates

The nodal coordinates are to be defined in the previously defined coordinate system. The y_0 and z_0 coordinates or the radius and the angle clearly define a node within the 2D system. Depending from the selected coordinate system, the coordinate parameters and column titles will change.

Via menu **Options** → **Units**, the units of the *Lengths* and decimals of the nodal coordinates can be customized (cf Figure 10.57, page 193).



If several nodes are selected, their collective properties can be modified by double-clicking. Now, only those input fields of the coordinates are filled with values that are identical for all selected nodes. In this way, deviations can be recognized or a new common coordinate can be assigned to all nodes.

Nodal coordinates can be also be imported from a DXF file (cf chapter 11.2, page 198) or from Excel (cf chapter 10.3.6, page 188). There are also two generators for hollow sections available which facilitate the definition of nodal coordinates (cf chapter 10.2.9, page 179 and chapter 10.2.10, page 180).

Principal Axis Coordinates

These two columns in the table remain empty during the input. After the calculation, the nodal coordinates will be listed with reference to the principal axes *y* and *z* of the section.

Comment

This column can be used to enter user-defined remarks.

5.2 Materials

General Description

Materials are essential to define elements and point elements. The limit stresses of the materials control the stress ratio, i.e. the utilization of the single elements.

SHAPE allows any material to be assigned and, if necessary, the inclusion of parts with different material characteristics and limit stresses. The ideal cross-section properties and the stresses are then determined with respect to the reference material.

The reference material can be set in the list of table 1.2 or in the *Details* tab of the *General Data* dialog box (cf Figure 4.37, page 56).

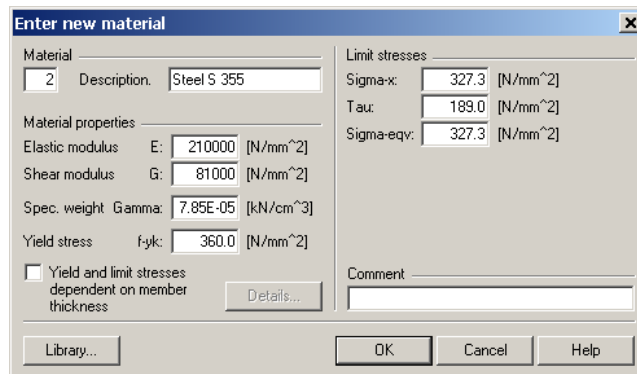
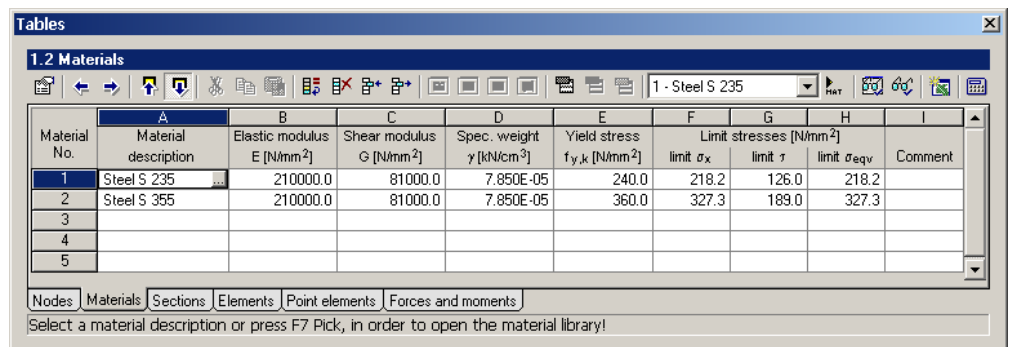

Figure 5.9: Dialog box *Enter new material*



Material No.	Material description	Elastic modulus E [N/mm ²]	Shear modulus G [N/mm ²]	Spec. weight γ [kN/cm ³]	Yield stress $f_{y,k}$ [N/mm ²]	Limit stresses [N/mm ²]			Comment
						limit σ_x	limit τ	limit σ_{eqv}	
1	Steel S 235	210000.0	81000.0	7.850E-05	240.0	218.2	126.0	218.2	
2	Steel S 355	210000.0	81000.0	7.850E-05	360.0	327.3	189.0	327.3	
3									
4									
5									

Figure 5.10: Table 1.2 *Materials*

Material Description

The description of the material can be chosen according to needs. When the name entered matches an entry of the material library, SHAPE imports all relevant material properties.

The import of materials from the library is described further below.

Elastic Modulus E

The modulus of elasticity is required to calculate the reduction factor λ .

For sections that consist of different materials, the elastic moduli will be converted with respect to the defined reference material (cf chapter 4.4.2.2, page 56).

The settings for the units and decimal places can be modified via menu **Options** → **Units**.

Shear Modulus G

The shear modulus G is the second parameter that describes the elastic behavior of a linear, isotropic and homogeneous material. It is also needed to determine the reduction factor λ .

Specific Weight γ

The specific weight γ describes the weight of the material per volume unit. It is required to calculate the weight of the section.

Yield Stress $f_{y,k}$

When this specific limit stress is reached, the steel begins to yield. The definition of the yield stress is relevant for these circumstances:

- Calculation of the plastic section properties
- Design of plastic capacity
- c/t Check according to the design methods elastic-plastic and plastic-plastic
- Calculation of the effective cross-section widths

In this column resp. input field, the characteristic value of the yield stress $f_{y,k}$ is entered. The design, however, has to be carried out with the design value of the yield stress $f_{y,d}$ which is determined according the following equation.

$$f_{y,d} = \frac{f_{y,k}}{\gamma_M}$$

Equation 5.1

The factor γ_M describes the safety factor of the material resistance. Thus, the index M is used. It is defined globally in the *Details* tab of the *General data* dialog box, cf chapter 4.4.2.2 on page 57.

When clicking on a cell in the *Yield stress* column of the table, the [...] button appears in this cell. This button calls up the new dialog box *Element thickness related yield stresses*. In the *Enter new material* dialog box, the [Details] button can be used after having activated the check box *Yield and limit stresses dependent on element thickness*.

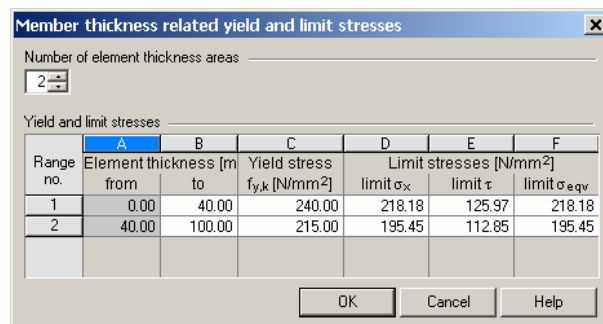
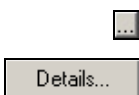

Figure 5.11: Dialog box *Element thickness related yield and limit stresses*

In this dialog box, up to eight *element thickness areas* can be defined. The respective *yield and limit stresses* can then be allocated to the thickness zones in the table.

Limit Stresses σ_x , τ , σ_{eqv}

These three columns resp. input fields define the allowable normal, shear and equivalent stresses.

Comment

This column can be used to enter user-defined remarks.

Material Library

Many materials are already stored in the so-called material library.

Call up the Library

The material library can be called up in the *New Material* dialog box by clicking on the [Library] button. The library is also accessible in table 1.2 *Materials*: Clicking on a cell in column A highlights a button within this cell. Click this [...] button, or press the [F7] key.

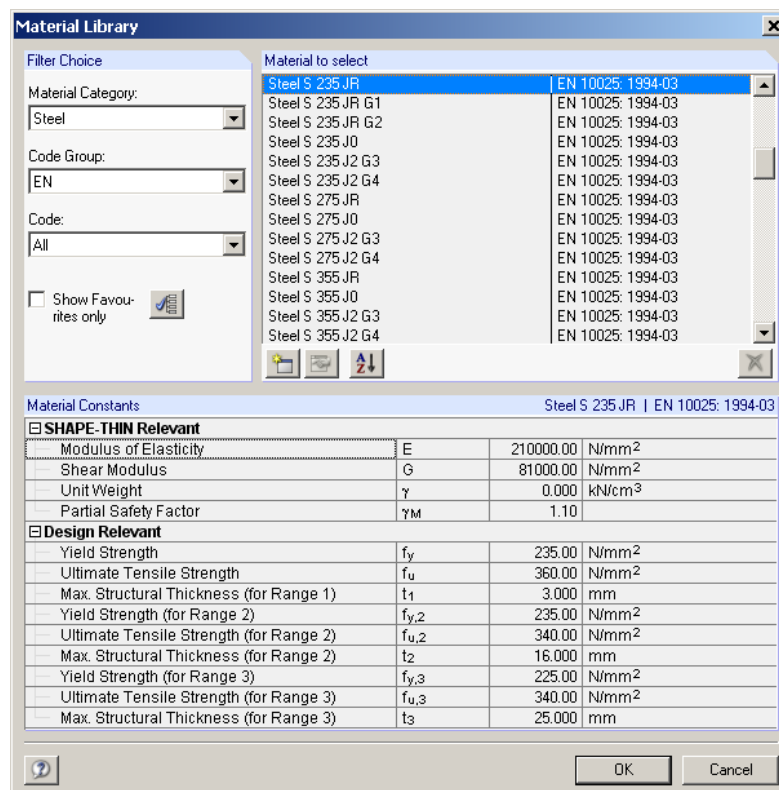

Figure 5.12: Dialog box *Material Library*

Materials can be selected from the list *Material to select*. The values can be controlled in the lower part of the dialog box. With [OK] or [↵], the material can be imported.

Filter Library

Because of the size of the material library, there are several *Filter* options. The material list is used to filter according to the criteria *Material category*, *Code group* and *Code*.

Create Favorites

Frequently used materials can be saved as favorites. If the option *Show favorites only* is active in the material library, only the selected materials will appear. The dialog box to create favorites is called up via the button [Edit Favorites and Sequence].



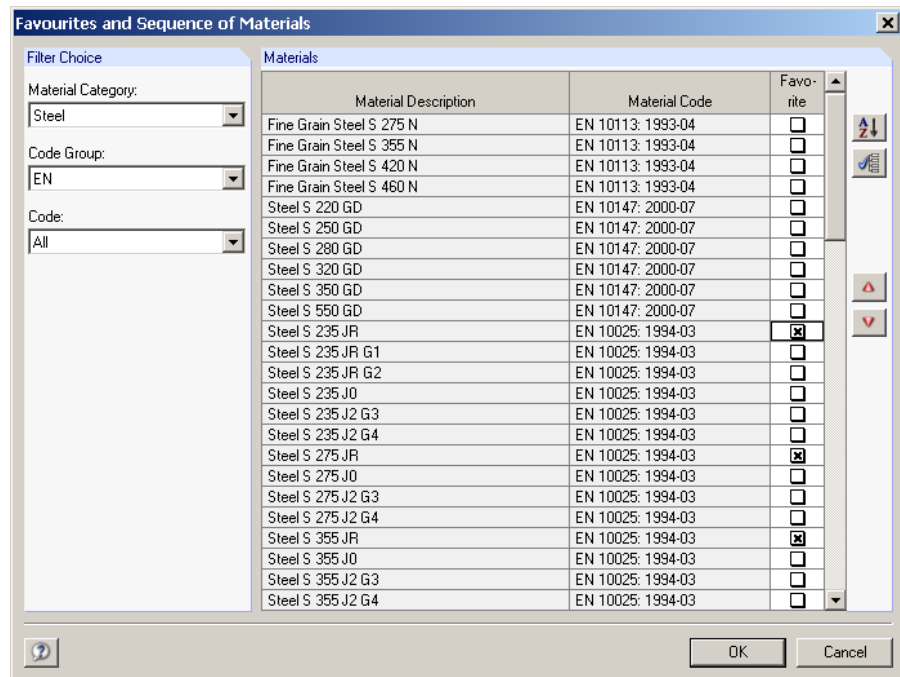

Figure 5.13: Dialog box *Favorites and Sequence of Materials*



This dialog box contains the already described filter options. Frequently used materials can be marked as *Favorite* by activating the check box in the last column of the *Materials* list. Also the sequence of the materials can be modified via the buttons [▲] and [▼].

If the check box *Show Favorites Only* is active, the material library looks more compactly.

The favorites also have an effect on the material that is preset when creating a new section: Additionally to the default *Steel S 235* material, the top favorite will be imported.

Expand Library

The data base for the materials is expandable. Immediately after adding a new material, it can be used for all SHAPE sections.



The button [Create New Material], which is located in the dialog section *Material to select* of the material library, opens the *New material* dialog box. The parameters of the selected item from the list *Material to select* are already set.

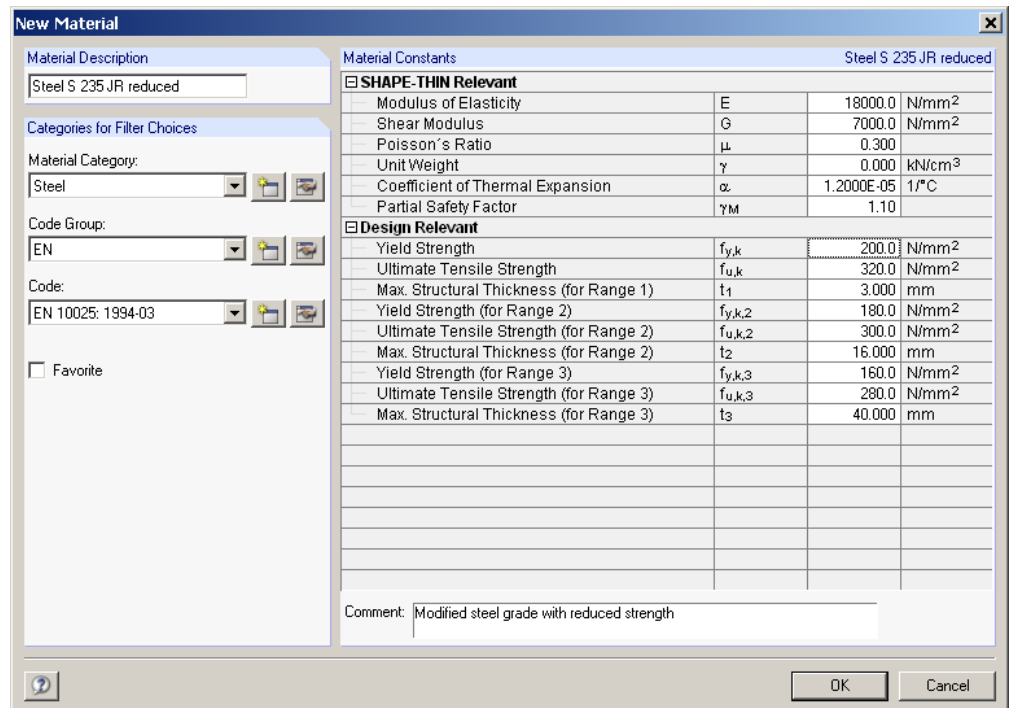

Figure 5.14: Dialog box *New Material*

The *Material Description* and the *Material Constants* are to be defined. Furthermore, suitable *Categories for Filter Choices* need to be specified. The categories can be either modified or newly created.

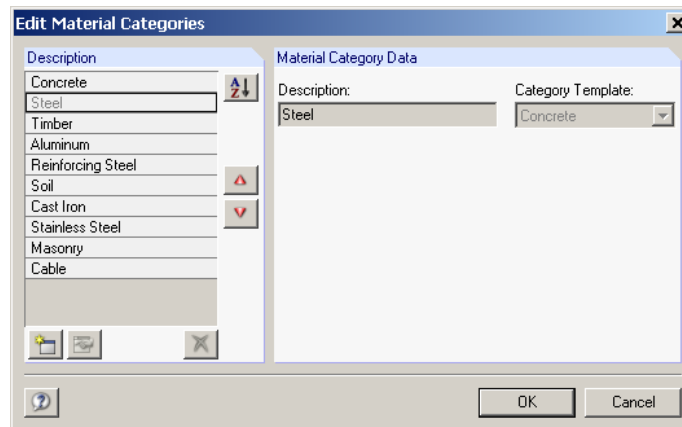

Figure 5.15: Dialog box *Edit Material Categories*



You can adjust the sequence of the items with the [▲] and [▼] buttons.

5.3 Sections

General Description

In SHAPE, types of rolled or welded cross-sections – the “sections” – can be chosen from an extensive library and be integrated in the SHAPE cross-section.

It is also possible to create user-defined sections from cross-sectional parts.

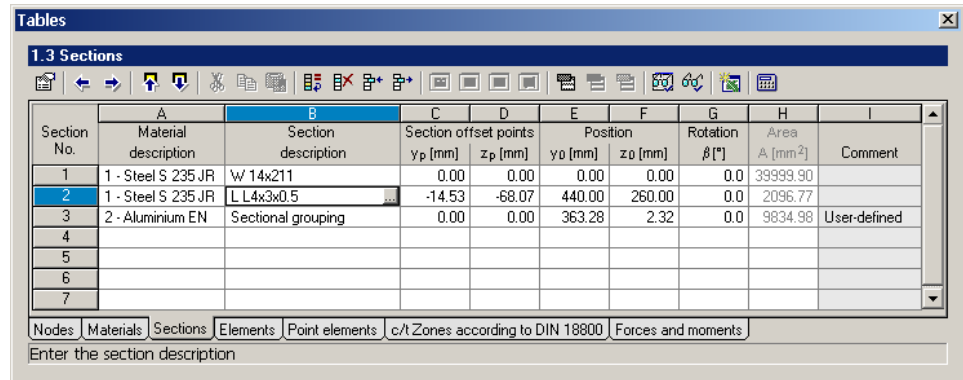

Section No.	Material description	Section description	Section offset points		Position		Rotation β [°]	Area A [mm ²]	Comment
			y_p [mm]	z_p [mm]	y_0 [mm]	z_0 [mm]			
1	1 - Steel S 235 JR	W 14x211	0.00	0.00	0.00	0.00	0.0	39999.90	
2	1 - Steel S 235 JR	L L4x3x0.5	-14.53	-68.07	440.00	260.00	0.0	2096.77	
3	2 - Aluminium EN	Sectional grouping	0.00	0.00	363.28	2.32	0.0	9834.98	User-defined
4									
5									
6									
7									

Figure 5.16: Table 1.3 Sections

Material Description

An entry can be selected from the list of the materials that have already been defined. This list is available via the [▼] button which appears at the end of the active cell.



In the *Set section* dialog box (cf. Figure 5.19), there are two buttons next to the list. These can be used to modify the material or to access the material library.

Details to the materials can be found in the previous chapter 5.2 on page 68.

Section Description

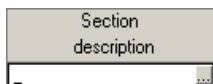

The *Section Description* has to correspond to a registered entry of the cross-section library if rolled or parameterized sections are to be used. It is recommended to use the [...] button in the table which calls up this library. There, the desired section can be selected. Its description will be imported into the table after having set the section.

How to set sections from the library is described below. In chapter 10.1.8 on page 171, it is explained how user-defined sections can be created from selected elements.

Section Offset Points

When setting the section graphically, a location of the cross-section is to be defined where to ‘grab’ it – the so-called *Offset Point*. In the *Set section* dialog box (cf. Figure 5.19), the coordinates of this offset point are shown in the two input fields above the image. Those coordinates y_p and z_p can be referred either (statically) to the centroid or (geometrically) to the center point of the section.

Position

These two columns of the table define the location of the offset point in the global coordinate system y_0 and z_0 .

Rotation β

It is possible to rotate the section about the angle β which can be freely defined.

Area

The value of the cross-sectional Area is imported from the library. For user-defined sections from selected elements, SHAPE immediately determines the area and shows the value here.

Library of Cross-Sections

There is a great variety of cross-sections available in a library.

Call up the Library

The cross-section library can be called up via the

- menu **Insert** → **Sections** → **Graphics** → **Section Library**
- button [Set section] in the toolbar
- button [...] or the [F7] key in column *Section description* of table 1.3 *Sections*.

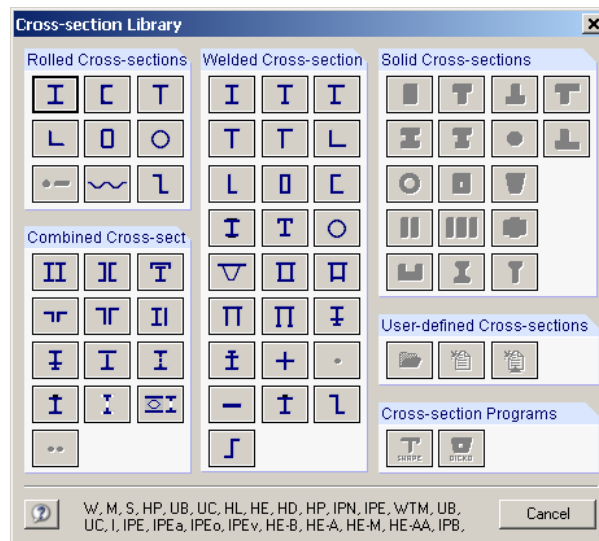

Figure 5.17: Dialog box *Cross-section Library*

Set Section

The types of cross-sections are divided into three groups: *Rolled*, *Welded* and *Combined Cross-Sections*. Due to the thin-walled calculation theory, both solid sections and round or flat bars are not accessible. Click one of the buttons to open a new dialog box with a list of all available sections in this group.

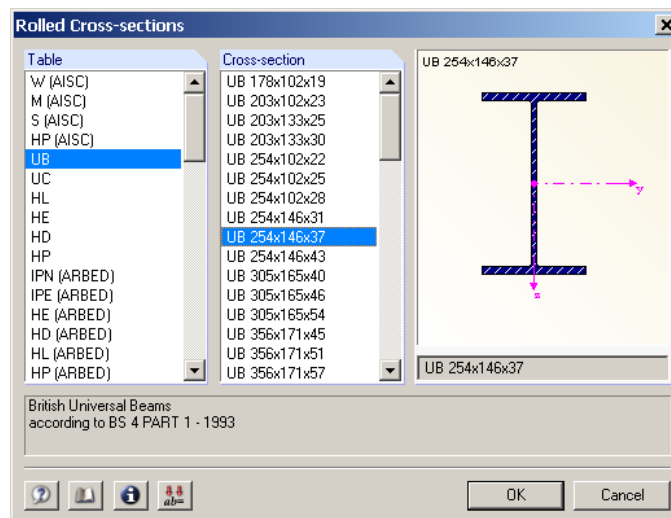
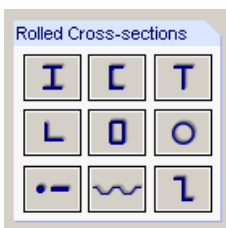

Figure 5.18: Selecting a rolled cross-section from the UB table



Here you first specify the *Table* so that you can select the relevant *Cross-Section*. You can use the [Details] button if you want to check the sectional properties of this cross-section.

When the cross-section has been chosen, click [OK] to open the final dialog box where the various parameters can be set before placing the section in the graphics.

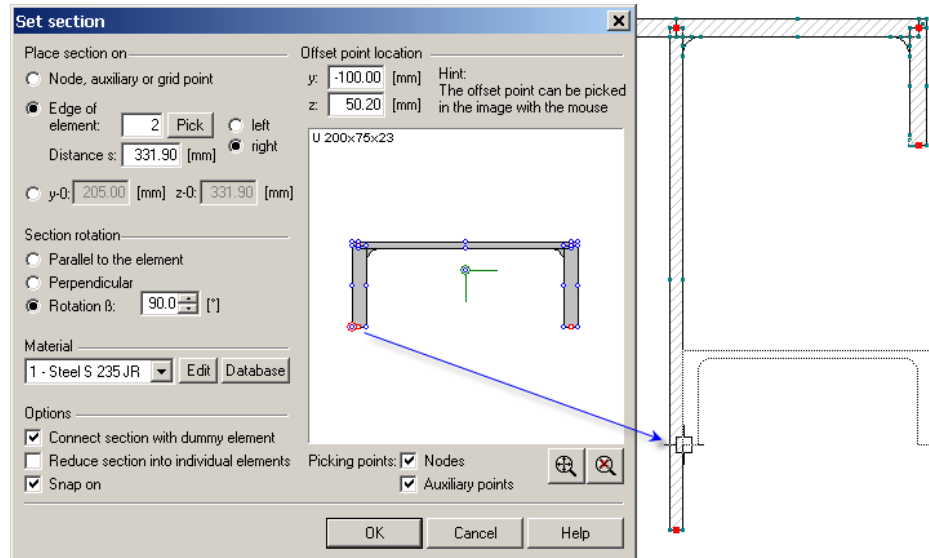

Figure 5.19: Dialog box *Set section*, option to connect section to *Edge of existing element*

The image in the right part of this dialog box shows the position of the current *Offset Point* which represents the “grab point” of the section. It is symbolized by a red circle. It is possible to define a different offset point by entering the coordinates of the *Offset point location* or by simply picking it in the image of the section. Regular *SHAPE Nodes* are shown in red, *Auxiliary points* in blue. The new offset point is then portrayed as a large red circle. If it is difficult to focus on the offset point, use the zoom function to enlarge the relevant area in the image.

There are three options in the dialog section *Place section on* to set the section at the

- *Node, auxiliary point or grid point* which can be picked in the graphics
- *Edge of element*, which creates a rigid connection via a *dummy* element to the *left* or *right* of the element that you can [Pick], at a certain *distance* of the element start
- Coordinates y_0 and z_0

It is possible to define a *Section rotation* about a user-definable angle β or by defining a *Parallel* or *Perpendicular* arrangement to the edge of another element.

The *Material* can be selected from the list or [Database], cf Figure 5.12 on page 70.

Optionally, it is possible to *Reduce the section into individual elements* so that its elements can be edited subsequently. The *Snap on* function is useful to set the section on the grid points. If auxiliary points are to be picked instead, this check box could be disabled.

When all input has been completed, confirm the settings with [OK]. It is faster, however, to set the section graphically by moving the dotted-line section over the screen to the desired location with the mouse. When the convenient node, auxiliary point or grid point is shown in the dialog box or status bar, the section can be set there by a single mouse click.

5.4 Elements

General Description



The geometry of the section is described by elements. Elements are defined by a start node and an end node and by a thickness that is assigned to this straight or curved line. Elements can only be connected with each other on nodes.

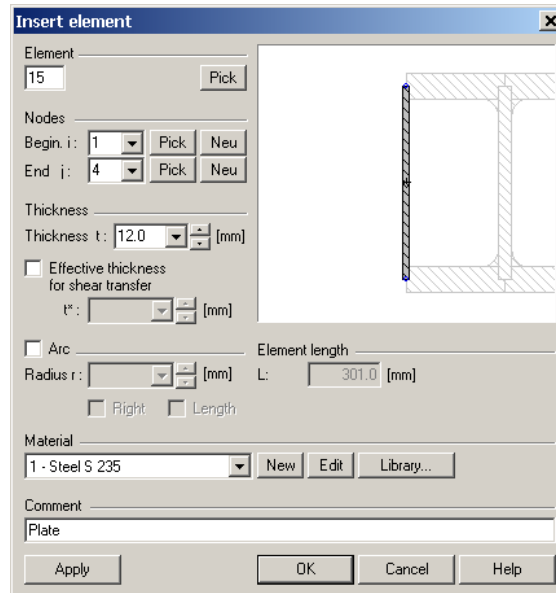
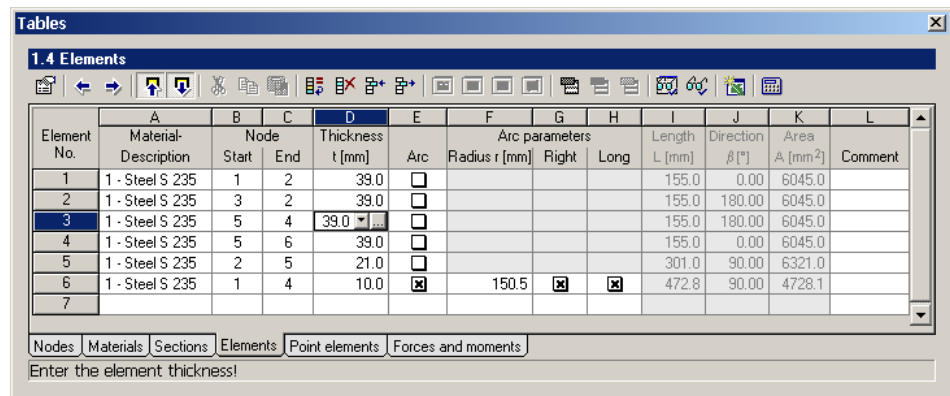

Figure 5.20: Dialog box *Insert element*



Element No.	Material-Description	Node Start	Node End	Thickness t [mm]	Arc	Arc parameters			Length L [mm]	Direction β [°]	Area A [mm ²]	Comment
						Radius r [mm]	Right	Long				
1	1 - Steel S 235	1	2	39.0	<input type="checkbox"/>				155.0	0.00	6045.0	
2	1 - Steel S 235	3	2	39.0	<input type="checkbox"/>				155.0	180.00	6045.0	
3	1 - Steel S 235	5	4	39.0	<input type="checkbox"/>				155.0	180.00	6045.0	
4	1 - Steel S 235	5	6	39.0	<input type="checkbox"/>				155.0	0.00	6045.0	
5	1 - Steel S 235	2	5	21.0	<input type="checkbox"/>				301.0	90.00	6321.0	
6	1 - Steel S 235	1	4	10.0	<input checked="" type="checkbox"/>	150.5	<input checked="" type="checkbox"/>	<input checked="" type="checkbox"/>	472.8	90.00	4728.1	
7												

Figure 5.21: Table 1.4 *Elements*

The element number is assigned automatically. If desired, a different number can be entered in the *Element* input field. The order of the numbering has no significance, gaps are permitted as well.

Material Description

An entry can be selected from the list of the materials that have been defined. It is possible to assign various materials to different elements within one section.

In the *Insert element* dialog box, there are three buttons next to the list. They can be used to create or modify materials and to access the material library.

Details to the materials can be found in chapter 5.2 on page 68.

Node Start - End

Every element is defined geometrically by a start node and by an end node. The order of those two nodes controls the orientation of the element, too. In turn, the element direction controls the results distribution on the element in some cases (e.g. statical moments).

The nodes can be entered manually, selected or newly defined.

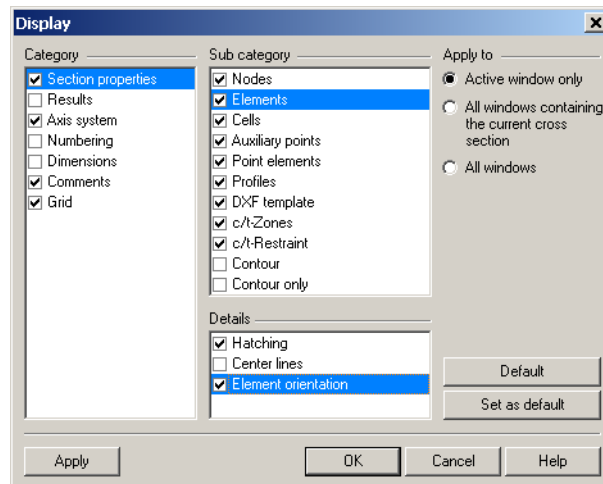

Figure 5.22: Activating the **Element orientation** in the *Display* dialog box



The element orientation can be changed quickly: Right-mouse click the element and select *Reverse Orientation* in the context menu. The numbers of the nodes for element start and end will then be exchanged.

Thickness t

The thickness t defines the thickness of standard elements. If the *effective thickness for shear transfer* is not identical to this thickness, however, the effective thickness t^* can be entered in a separate input field resp. dialog box that is called up via the [...] button at the end of this input field in the table.

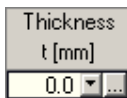

The effective thickness is relevant especially for dummy elements. SHAPE recognizes the thickness zero as a non-interruption of the shear flow. For certain formulae, the thickness must be greater than zero, however, as t is in the denominator.



Figure 5.23: Dialog box *Effective thickness t^**

Arc

The check box in the *Insert element* dialog box or in the table column controls whether the element is straight or curved. The following input fields are only accessible when the box is marked with a cross, which can be done by a single mouse click.



In the analysis, arcs are taken into account as straight elements based on polygonal lines. The internal division of arcs can be specified in the *Details* tab of the *General Data* dialog box (cf Figure 4.37, page 56).

Arc Parameters



Although an arc can be defined in the *Insert element* dialog box by activating the option *Arc* (cf Figure 5.20), there is an extra button available in the toolbar to set arcs graphically. It calls up the following dialog box.

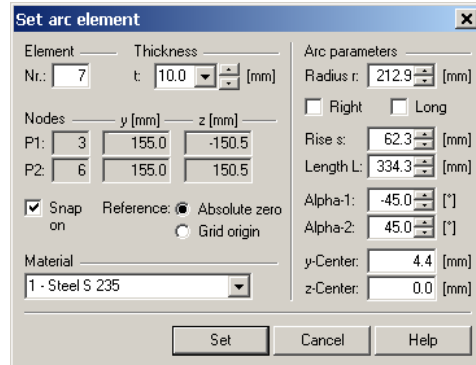

Nodes	y [mm]	z [mm]
P1:	3	-150.5
P2:	6	150.5

Figure 5.24: Dialog box *Set arc element*

Radius r

The radius must be large enough for the arc to be created between the two nodes. In the *Set arc element* dialog box, the two nodes are to be picked in the graphics before the radius can be defined. This can be done either by entering the size of r directly and then pressing [Set] (but be careful not to leave the dialog box with the mouse), or by simply moving the mouse pointer with the dotted-line arc over the screen and selecting the radius with a final mouse click.

Right

This check box controls whether the arc is created to the right or to the left of the line which is defined by the start and end node.

Long

By activating or deactivating this check box, it can be defined whether the arc is longer or shorter than the semicircle with the same radius.

In the *Set arc element* dialog box, further parameters are listed that depend on the above input and which can be accessed directly as well (e.g. *Rise* of the arc, opening angles *Alpha* and absolute coordinates of the arc *Center*).

The fastest way to modify an existing arc is to double-click it in the graphics and then adjust its parameters in the *Edit element* dialog box.

Length L

This column of the table shows the total length of the straight or curved element.

Direction β

The inclination angle of the element (or of the straight line between start and end nodes of an arc) towards the axis y_0 is specified so that the position of the element can be checked.

Area A

The values represent the gross areas of each element. They are the products of the element thicknesses t and the element lengths L . Overlappings are not considered here. For arcs, the areas are determined by the inner and outer radii.

Comment

This column can be used to enter user-defined remarks. If an element is part of a specific section (cf previous chapter 5.3), the section description is listed here.

5.5 Point Elements

General Description

Point elements are useful to add or to remove small sectional parts. Thus, fillets or notches can be modeled in detail, for example. The sections of the section library also include point elements internally, which can be noticed after having reduced the section into its elements. Stresses in point elements are not covered by the analysis, however.



Please note that the ratio of all point elements should not exceed 10 % of the sectional area so that the section properties can be determined correctly. If a point element is of considerable size, it is rather to be modeled by using a 'real' element.

Point elements can be 'grabbed' at the offset points that are displayed in the image of the dialog box. When a new offset point is chosen by clicking on it in this image, it is highlighted by a larger circle. You can then move the dotted-line point element at this offset point over the screen and connect it to a node or auxiliary point of an element or point element.

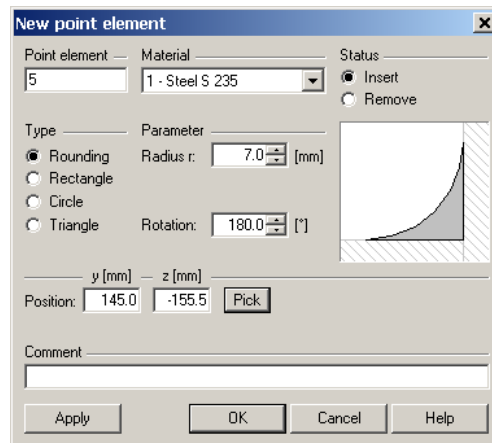

Figure 5.25: Dialog box *New point element*

Points. no.	Status	Type	Material-Description	Position		Radius [mm]	Rotation β [°]	Area A [mm ²]	Comment
				yo [mm]	zo [mm]				
1	Insert	Rounding	1 - Steel S 235	124.7	106.1	9.40	0.0	19.0	
2	Insert	Rectangle	1 - Steel S 235	129.4	105.1	9.40/1.98	0.0	18.6	
3	Insert	Triangle	1 - Steel S 235	134.1	104.1	14.15/1.98	0.0	14.0	
4	Remove	Rectangle		173.7	102.5	5.60/3.17	0.0	-17.8	
5	Remove	Triangle		170.9	104.1	22.65/3.17	180.0	-35.9	
6	Remove	Rounding		176.5	100.9	5.60	180.0	-6.7	
7	Insert	Rounding	1 - Steel S 235	124.7	333.9	9.40	-90.0	19.0	

Figure 5.26: Table 1.4 *Point elements*

The point element number is assigned automatically. If desired, a different number can be entered in the *Point element* input field. The order of the numbering is insignificant.

Status

It is possible either to *Insert* or to *Remove* point elements to resp. from the sectional model. In the following image of an I-shape section of the library, the flanges are modeled in detail by inserted and removed point elements.

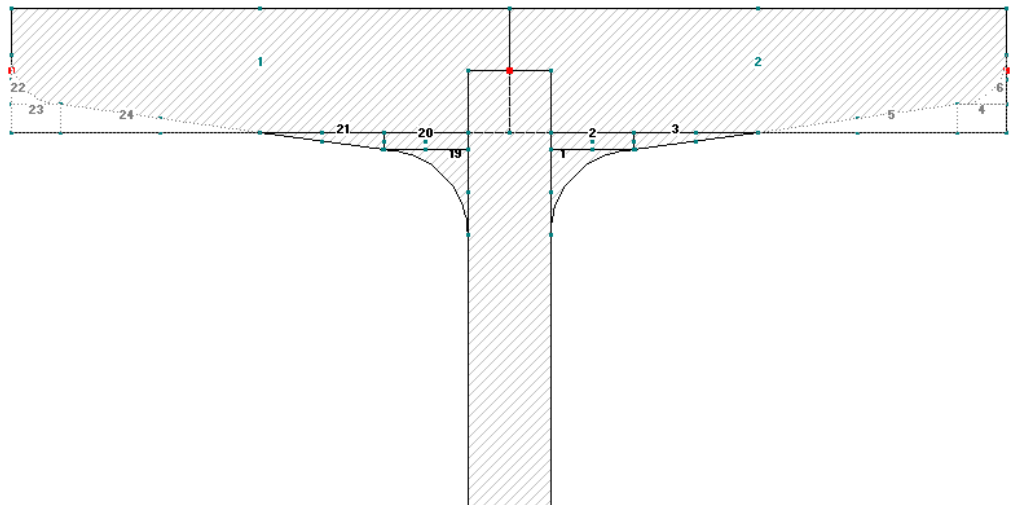

Figure 5.27: Flange of I-section with inserted and removed point elements

Type

There are four types of point elements available that allow for a detailed modeling.



Type	Image	Description
Rounding		This point element represents a square with a removed quadrant sector. The <i>Radius r</i> has to be defined. There are three offset points available.
Rectangle		The rectangle is described by the two parameters <i>Length</i> and <i>Width</i> . Apart from the offset point in the center, one of the four offset points at the corners can be used to set the point element.
Circle		The circular point element is defined by its <i>Radius r</i> . Apart from the offset point in the center, there are four offset points on the circumference available.
Triangle		A right-angled triangle is identified by the parameters <i>Length</i> and <i>Width</i> . There is an offset point in every corner of the triangle.

Table 5.1: Types of point elements

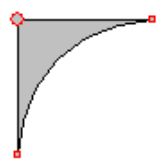
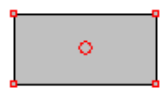
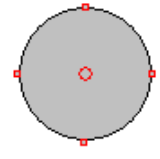

The adequate offset point can be chosen by a single mouse click. If the parameters of the point element (length, width or radius) are modified subsequently, it may be necessary to update the offset point by picking it again.

Material Description

An entry can be selected from the list of the materials that have been defined. It is possible to assign various materials to different elements within one section.

In the *Insert element* dialog box, there are three buttons next to the list. They can be used to create or modify materials and to access the material library.

Details to the materials can be found in chapter 5.2 on page 68.

Position y_0 , z_0

These two input field resp. table columns define the location of the point element with reference to the global origin (0/0). To be precise, these coordinates represent the position of its offset point (cf Table 5.1).

Length/Width resp. Radius

The geometrical parameters of the point element depend on its type. For a rectangle or a triangle, the *Length* and *Width* are to be specified. For a rounding or a circle, the *Radius* r is has to be defined.

Radius [mm]
6.30

To modify the parameters in the table, the [...] button can be used. It appears when you click the cell. It calls up the *Edit point element* dialog box in which the parameters can be adjusted.

Rotation β

It is possible to rotate the point element about the angle β which can be freely defined.

Area A

The area of every point element is listed in this table column. This value is positive if the point element is inserted and negative if it is removed.

Comment

This column can be used to enter user-defined remarks. If a point element belongs to a specific section (cf chapter 5.3), the section description is listed here.

5.6 c/t Zones

General Description

For stress analyses, the ratio of width to thickness c/t is important so that full contribution of sectional parts in the case of compressive stresses is warranted.

The c/t zones are only accessible in the graphics and in the table if one of the following options has been enabled in the *General data* dialog box (cf Figure 4.33, page 53):

- Check limiting c/t
- Effective cross-sections



Internal forces must be defined, too, in order to check the width-to-thickness ratios.

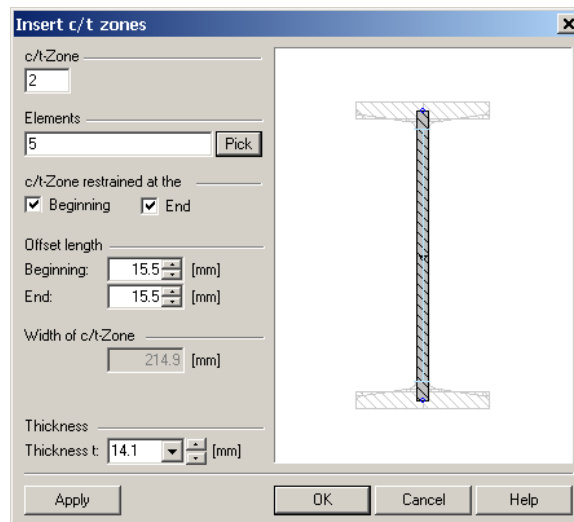
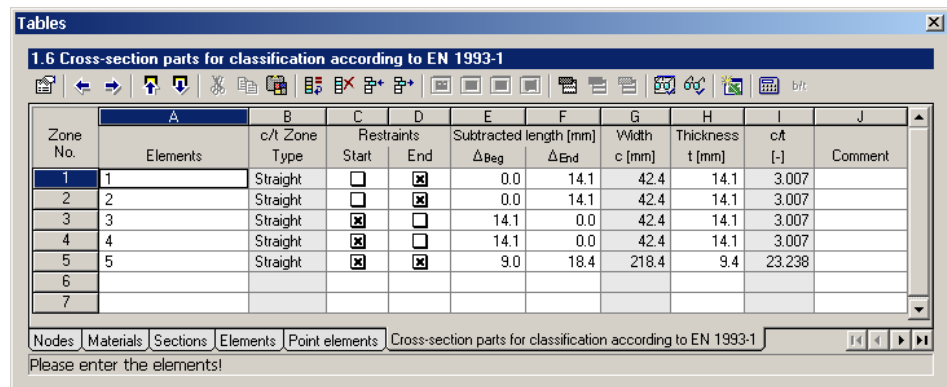

Figure 5.28: Dialog box *Insert c/t zones*



Zone No.	Elements	c/t Zone Type	Restraints Start	Restraints End	Subtracted length [mm] ΔBeg	Subtracted length [mm] ΔEnd	Width c [mm]	Thickness t [mm]	c/t [-]	Comment
1	1	Straight	<input type="checkbox"/>	<input checked="" type="checkbox"/>	0.0	14.1	42.4	14.1	3.007	
2	2	Straight	<input type="checkbox"/>	<input checked="" type="checkbox"/>	0.0	14.1	42.4	14.1	3.007	
3	3	Straight	<input checked="" type="checkbox"/>	<input type="checkbox"/>	14.1	0.0	42.4	14.1	3.007	
4	4	Straight	<input checked="" type="checkbox"/>	<input type="checkbox"/>	14.1	0.0	42.4	14.1	3.007	
5	5	Straight	<input checked="" type="checkbox"/>	<input checked="" type="checkbox"/>	9.0	18.4	218.4	9.4	23.238	
6										
7										

Figure 5.29: Table 1.6 *Cross-section parts for classification according to EN 1993-1*

SHAPE detects the c/t zones automatically and displays them in the graphics and the table. In the *General data* dialog box, the settings when to create end restraints of the c/t zones can be controlled (cf Figure 4.43, page 60 and Figure 4.44, page 61).

If several elements are connected in a straight line, SHAPE automatically recognizes the continuous lengths (inclusive of dummy elements) in order to determine the c/t ratio of this sectional part. An end support will be assumed where another element is connected at an angle greater than 45° by default. The settings can be controlled in the *General data* dialog box (cf Figure 4.43, page 60 for DIN 18000 and Figure 4.44, page 61 for EN 1993-1).

Elements

All elements that belong to the c/t zone are listed in this input field of the dialog box or table.

c/t Zone Type

In this table column, every c/t zone is assigned automatically to one of the following types:

- Straight
- Arc
- CHS (circular hollow section)

This table column is not accessible for user-defined specifications.

Restraints Start / End

Every c/t zone can be supported at its start and/or end, or it can be without a restraint on one side. Thus, internal compression parts or outstand flanges are defined.

Subtracted Length Δ_{Start} / Δ_{End}

In these two input fields of the dialog box or table, the distance of the restraint from the start resp. end node of the relevant element is defined. If there is no restraint, the distance is zero in general. Thus, it is possible to reduce the width of the c/t zone by taking into account connecting elements or fillets. SHAPE automatically recognizes favorable effects.

Width c

The total width of a c/t zone is made up of the lengths of all contained elements which is reduced by the subtracted lengths at the start and end of this zone.

Thickness t

The thickness is defined as the smallest thickness of all elements which are integral parts of the c/t zone.

Existing c/t

In this table column resp. dialog box field, the resulting width-to-thickness ratio is listed.

5.7 Forces and Moments

General Description

In this table, internal forces and moments can be defined or imported from RSTAB or RFEM. Those are the basis of the sectional design which can be carried out by load cases and locations x . The entire input is done in the table 1.7, i.e. there is no specific input dialog box.

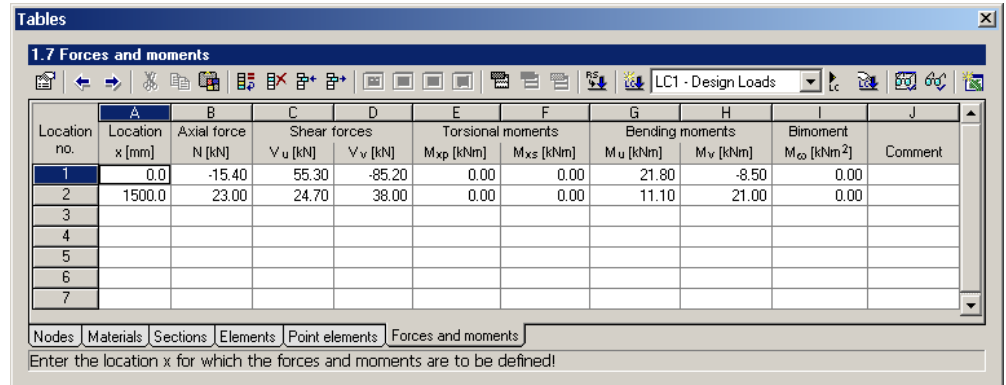

Location no.	Location x [mm]	Axial force N [kN]	Shear forces V _u [kN]	V _v [kN]	Torsional moments M _{xp} [kNm]	M _{xs} [kNm]	Bending moments M _u [kNm]	M _v [kNm]	Bimoment M _ω [kNm ²]	Comment
1	0.0	-15.40	55.30	-85.20	0.00	0.00	21.80	-8.50	0.00	
2	1500.0	23.00	24.70	38.00	0.00	0.00	11.10	21.00	0.00	
3										
4										
5										
6										
7										

Figure 5.30: Table 1.7 Forces and moments

The location number is assigned automatically, but the order of the numbering is irrelevant.

Location x

These locations define e.g. the positions along a beam where the associated internal forces occur. This location x , however, needs not necessarily represent a real position of the beam. Different locations x can be defined manually to design the section if its internal forces give not immediate evidence about the position of the maximum stresses.

When entering the first location x , the load case 1 will be created automatically. See below for details on how to create load cases or to import internal forces from RSTAB or RFEM.

Although identical locations x are permitted, they make the evaluation of the results a bit difficult.

Axial Force N

An axial force N results in the normal stress $\sigma_{x,N}$ which is constant in the section.

Tensile forces are entered with positive signs, compressive forces with negative signs.

Shear Forces V_u / V_v

The shear forces V_u and V_v (acting in the direction of the principal axes u and v) result in the shear stresses τ_{Vu} and τ_{Vv} . If they act parallel to the global axes y_0 and z_0 , the column titles are labeled as V_y and V_z . In this case, they result in the shear stresses τ_{Vy} and τ_{Vz} .

The reference of the internal forces can be set in the *Details* tab of the *General Data* dialog box (cf Figure 4.37, page 56) which can be called up via menu

Edit → Section properties → General data.

Torsional Moments M_{xp} / M_{xs}

If the shear force does not act in the shear center M or lateral restraint D , the section is additionally subjected to torsion. This results in a torsional moment (torque) about the longitudinal axis x of the beam.

In these columns, the two components of the torsional moment M_x can be entered – the primary torsional moment M_{xp} and the secondary torsional moment M_{xs} . If the effects of warping torsion are of no concern, then only the primary torsional moment M_{xp} is relevant, i.e. M_{xs} can be set to zero.

$$M_{xp} = -V_y \cdot e_z + V_z \cdot e_y \text{ or}$$

$$M_{xp} = -V_y \cdot (z_M - z_{Vy}) + V_z \cdot (y_{Vz} - y_M)$$

Equation 5.2

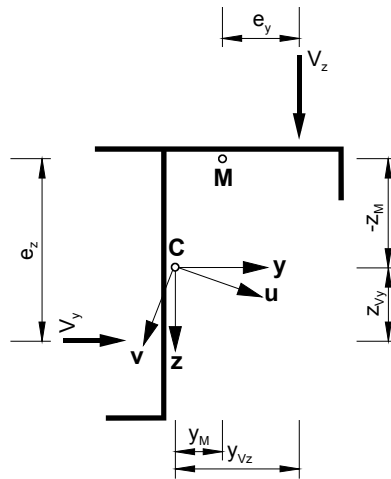

Figure 5.31: Eccentricities e_y and e_z

If the positive axis y is oriented to the right, M_{xp} is defined as positive when the torsional moment rotates clockwise about the shear center M .

Instead of the common shear center M , it is possible to define a different point of rotation. The lateral restraint D can be specified in the *Details* tab of the *General Data* dialog box (cf Figure 4.37, page 56) which is called up via menu

Edit → **Section properties** → **General data**.

For sections that can be considered as warp-free in general (e.g. closed sections), the warping torsional effects may be neglected. The secondary torsional moment M_{xs} can then be set as zero.

M=C and t=constant

One intersection

Figure 5.32: Warp-free and quasi-warp-free sections

The torsional moment M_{xs} will be relevant for open, thin-walled, non-warp-free sections (e.g. I-, W- or C-shape sections). The total torsional moment M_T has then to be split up into the M_{xp} component (causing primary torsional shear stresses from St. Venant torsion) and the M_{xs} component (causing secondary torsional shear stresses due to warping restraint). The two values are then to be entered in the table columns.

Bending Moments M_u / M_v

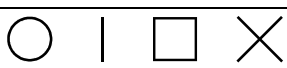
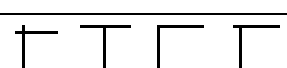
The moments M_u and M_v (acting in the direction of the principal axes y and z) result in the normal stresses σ_{x,M_u} and σ_{x,M_v} . If they act parallel to the global axes y_0 and z_0 , the column titles are labeled as M_y and M_z . In this case, they result in the normal stresses σ_{x,M_y} and σ_{x,M_z} .

The reference of the moments can be set in the *Details* tab of the *General Data* dialog box as described for the shear forces.

The sign convention in SHAPE corresponds to that of RSTAB, RFEM and RF-/STEEL: M_y is positive when there are tensile stresses on the positive member side (i.e. in direction of its axis z). M_z is positive when there are compressive stresses on the positive member side (i.e. in direction of the member axis y). The following figure illustrates the sign convention.

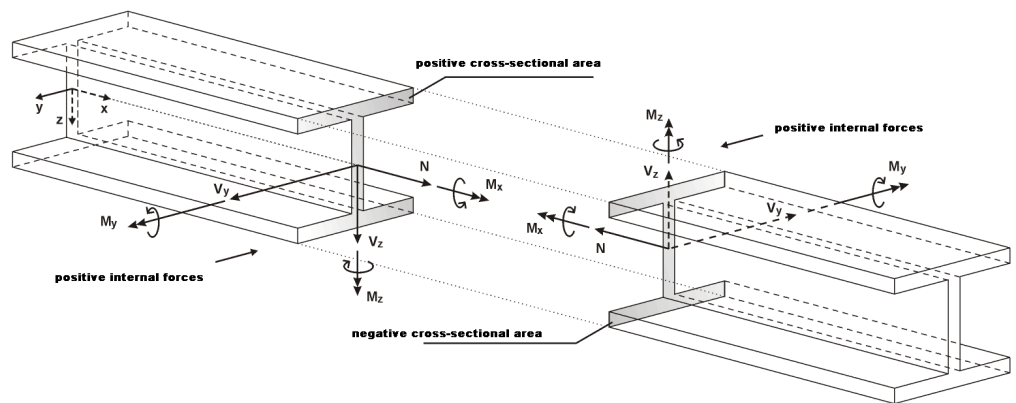

Figure 5.33: Sign rule for internal forces and moments

Bimoment M_ω

The bimoment causes warping normal stresses σ_{x,M_ω} .

If the stresses are to be calculated without consideration of the warping torsion on account of a warp-free, quasi-warp-free, closed or not warp-restrained section, then the moments $M_{x,s}$ and M_ω can be set as zero for the design. Here, the torsional moment $M_{x,p}$ corresponds to the common torsional moment M_T .

Comment

This column can be used to enter user-defined remarks on the internal forces.

Via menu **Options** → **Units**, the units of the *Forces* and *Moments* and the decimals can be customized (cf Figure 10.57, page 193).

Create Load Case

Different combinations of internal forces can be organized either in separate load cases or by defining different locations x within one and the same load case. If there are only few line-ups of internal forces, the last-mentioned alternative will be sufficient.

A new load case can be created via the

- menu **Insert** → **New Load Case**
- button [New Load Case] in the toolbar of table 1.7 *Forces and moments*

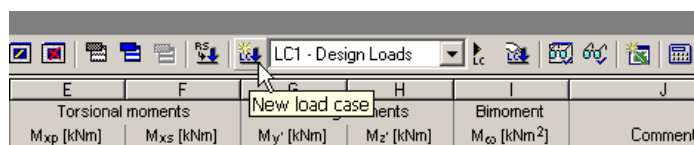

Figure 5.34: Button *New load case* in the table toolbar

- context menu of the navigator item *Forces and moments*.

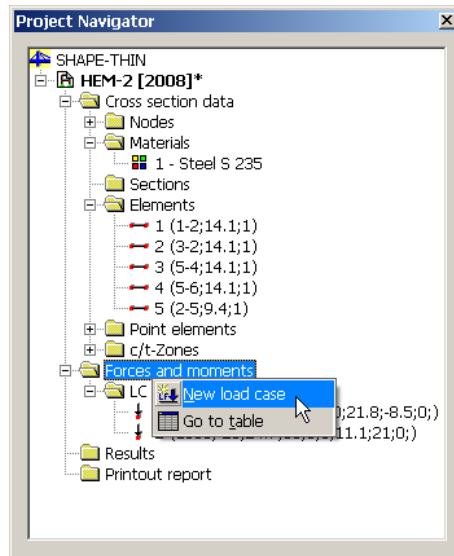

Figure 5.35: Context menu *Forces and moments* in the navigator

The *New Load Case* dialog box is opened.

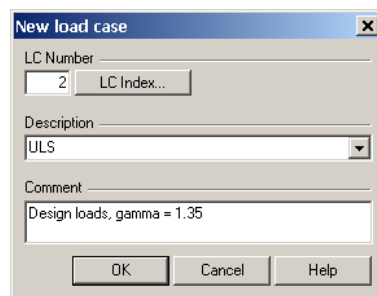

Figure 5.36: Dialog box *New load case*

LC Index...

The *LC Number* is allocated by the program, but can be replaced by a different number. If this number already exists, a warning will appear and the dialog box cannot be closed. The button [LC Index] opens an overview of all load cases that have already been defined.

In the input field *Load Case Description*, a name can be assigned. The description can be entered or selected from the list. It is also possible to add an explicative *Comment*.

Import Internal Forces from RSTAB or RFEM

The calculated internal forces of RSTAB or RFEM members can be imported via the

- menu **Extras** → **Import results from RSTAB** (table 1.7 must have been set)
- button [Import Results] in the toolbar of table 1.7 *Forces and moments*.

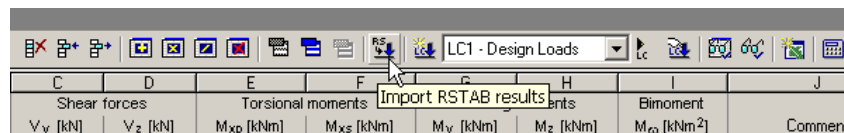
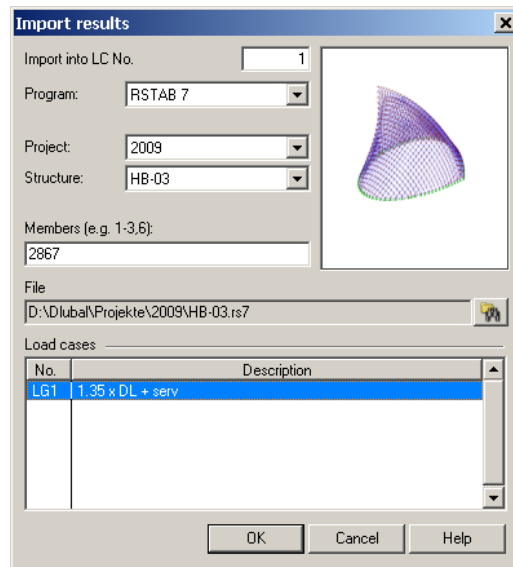

Figure 5.37: Button *Import RSTAB results* in the table toolbar

A dialog box opens in which you can make your choice.

Figure 5.38: Dialog box *Import Results*

In the input field *Import into LC No.*, the first free load case number is preset. A different number can be entered if necessary.

First select the *Program* (e.g. RSTAB 7, RFEM 4), then the *Project* and finally the *Structure* whose results are to be imported. The choice can be made from the list boxes which are opened when clicking on the input fields.

As soon as the position has been selected, the image of the structure is shown to the right and all calculated *Load cases* are listed below. Of course, load groups, load combinations and super combinations are also included in this list which is sorted by *No.* and associated *Description*. Select the desired load case with a mouse click.

In the *Members* input field, enter the relevant numbers of the members. It is recommended to select only specific members in order to limit the number of locations *x* that are to be imported, which facilitates the evaluation of the results later on.



The [Browse] button makes it possible to choose a different folder. Thus, structures can be accessed that are not contained in projects of the RSTAB/RFEM Project Manager.

[OK] imports the selected member results into table 1.7 *Forces and moments*. As load case description, SHAPE automatically includes the program and structure name, the member numbers and the original load case description.

The forces and moments are imported at the locations *x* subject to the number of divisions for the member results in RSTAB or RFEM. To avoid identical locations *x* when importing the results of several members, SHAPE adds up the locations of all members successively.

For load combinations, however, adding up locations *x* is not possible even within one and the same member. Thus, there are several identical locations *x* with the distinct maxima and minima, together with the associated internal forces.

For clearly arranged combinations of results, irrelevant table rows can be deleted one by one via e.g. [Ctrl]+[Y]. Alternatively, select those rows with the pressed mouse button in column *Location No.* Then call up the context menu with the right mouse button to *Delete* the selected rows.

Tables

1.7 Forces and moments

LC2 - From RSTAB 6, S

Location no.	A Location x [mm]	B Axial force N [kN]	C Shear forces V _u [kN]		D Torsional moments M _{xp} [kNm]		E Bending moments M _u [kNm]		F M _{xs} [kNm]	G M _v [kNm]	H M _w [kNm ²]	I Bimoment M _ω [kNm ²]	J Comment
1	0.0	-87.33	-0.05				4.49	-0.14				0.00	
2	1320.0	-88.69	-0.05				2.27	-0.07				0.00	
3	2640.0	-90.04	-0.08				0.00	0.00				0.00	
4	2640.0	-92.16	-0.08				-2.38	-0.23				0.00	
5	3960.0	-93.52	-0.09				-1.20	-0.12				0.00	
6	5280.0	-94.87	-0.09				0.00	0.00				0.00	
7	5280.0	-91.36	0.09				-11.03	0.25				0.00	
8	6600.0	-92.71	0.10				-5.58	0.13				0.00	
9	7920.0	-94.07	0.10				0.00	0.00				0.00	
10	7920.0	-81.21	0.03				-15.50	0.09				0.00	
11	9240.0	-82.57	0.03				-7.83	0.04				0.00	
12	10560.0	-83.92	0.03				0.00	0.00				0.00	
13	10560.0	-72.35	-0.06				61.76	-0.08				0.00	
14	11660.0	-73.31	-0.06				33.52	-0.01				0.00	

Nodes | Materials | Sections | Elements | Point elements

Enter the location x for which the forces and moments are to be calculated

Context menu: Deselect (Ctrl+U), Cut (Ctrl+X), Copy (Ctrl+C), Paste (Ctrl+V), Delete (Ctrl+Del), Add..., Multiply..., Divide..., Set, Generate (Ctrl+G), Save..., Import...

Figure 5.39: Table context menu to Delete selected lines

6. Calculation

Before the calculation is started, it is recommended to check whether the data are complete and the references of the data sets are correct.

Detected input errors can easily be corrected as the table line with the problem is called up directly.

6.1 Plausibility Check



The plausibility check is called up via menu

Extras → Plausibility Check

or the corresponding button in the toolbar of the tables.

The check is carried out immediately afterwards. If no errors are detected, SHAPE shows an according message. A warning is displayed when a mismatch has been detected, however.

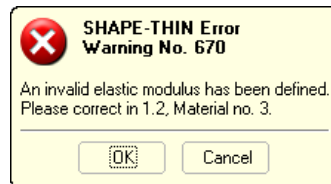

Figure 6.1: Plausibility check with warning

6.2 Crossing Elements

The sectional model can be explicitly checked for elements that cross but have not common node at the intersection. This test is also included in the above-mentioned plausibility check.

The examination for crossing elements can be started via menu

Extras → Check for crossing elements.

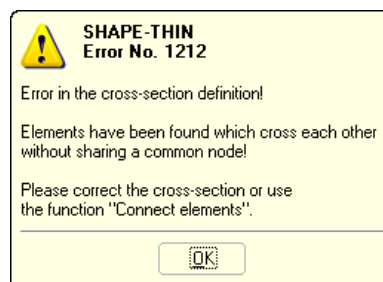

Figure 6.2: Check for crossing elements

If there are crossing elements, a warning appears, and the elements are highlighted in the graphics. The sectional model can then be corrected manually or by applying the function *Connect elements* (cf. chapter 10.2.4, page 176).

6.3 Interconnecting Elements

Before the calculation, SHAPE decides whether the section consists of elements that are all interconnecting or whether there are several independent sectional parts.

The check for interconnecting elements can be carried out via menu

Extras → Check for interconnecting elements.

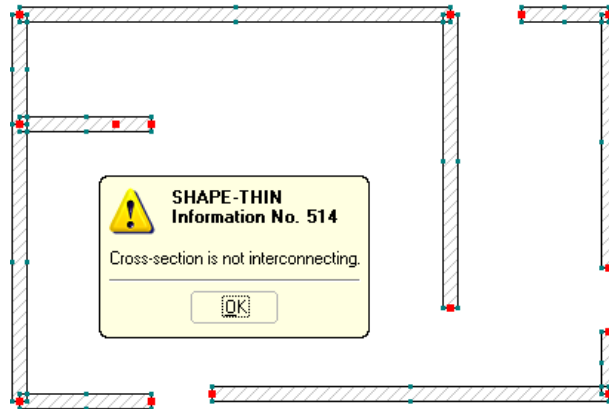

Figure 6.3: Check for interconnecting elements

This classification is important with respect to the calculation theory: If the elements are not connected, the individual parts will be assumed as shear-flexible. The sectional properties are calculated according to the theory of stiffening shear walls. There, it is assumed that the global section is made up of individual shear walls (braced panels) which are tied to each other via floors or beams. The calculation of the section properties and stresses is carried out in a different manner than for coherent sections (e.g. moment of inertia without the parallel axis theorem component $A_i \cdot e_i^2$, cf chapter 7.8 on page 122).

Unconnected sectional parts can be joined via menu

Extras → Connect nodes and elements.

Dummy elements are automatically created between the unconnected parts of the section. This function is described in chapter 10.2.5 on page 177.

6.4 Plastic Calculation

The parameters of the plastic calculation are controlled in the *Plastic calculation* tab of the *General Data* dialog box. It can be called up via menu

Edit → Section properties → General data.

This tab is described in chapter 4.4.2.3 on page 59.

In most cases, the default settings represent a practical compromise between accuracy and calculation speed. The more Simplex elements are to be processed, the more time the analysis will take.

6.5 Start Calculation

There are several options to start the calculation. Before, it is advisable to perform a short plausibility check of the input data (cf chapter 6.1, page 90).



The analysis can be started via the

- menu **Results** → **Display Results**,
- button [Display results] in the toolbar,
- function key [F5].

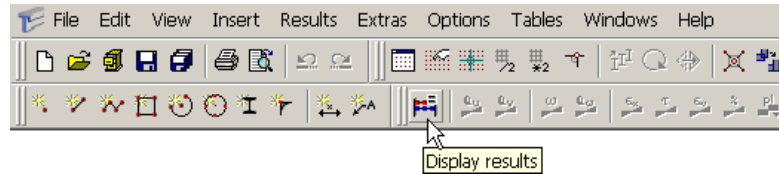

Figure 6.4: Button *Display results*

If there are unconnected elements in the sectional model, SHAPE inquires whether the section is to be calculated according to the shear wall theory which applies different formulae.

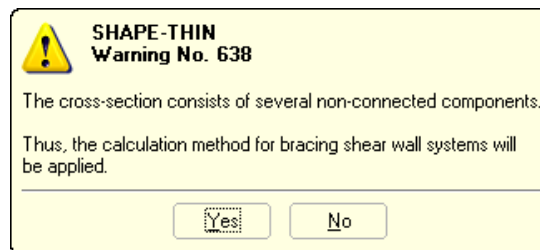

Figure 6.5: Warning before calculating shear-flexible sections

7. Results

Immediately after the calculation, the results are displayed in the section graphics and in the results tables (cf chapter 4.3.4, page 39).

The available results tables depend on the settings specific to the calculation, i.e. stresses, c/t check, plastic design, effective cross-section widths or shear wall section.

7.1 Section Properties

Table 2.1 *Section properties* presents all significant sectional characteristics. To view the entire list, you can enlarge the table window by pulling up its top edge with the mouse. Alternatively, the function *Display rows* can be used to hide those properties that are of secondary importance (cf Figure 10.47 on page 188).

Description	Symbol	Value	Unit	Comment
Cross-sectional area	A	105.35	cm ²	
Shear areas	A _u	48.50	cm ²	
	A _v	30.27	cm ²	
Centroid position	y _{c,0}	22.64	cm	related to absolute zero
	z _{c,0}	8.16	cm	
Moments of inertia	I _y	14690.60	cm ⁴	about centroidal axes y, z
	I _z	10786.30	cm ⁴	
	I _{yz}	-1119.84	cm ⁴	
Inclination of principal axes	α	14.92	°	clockwise positive
Principal moments of inertia	I _u	14988.90	cm ⁴	about principal axes u, v in C
	I _v	10487.90	cm ⁴	
Polar moments of inertia	I _p	25476.80	cm ⁴	
	I _{p,M}	36492.70	cm ⁴	about shear center M
Radii of gyration	i _y	11.81	cm	related to centroid C
	i _z	10.12	cm	
	i _{yz}	3.26	cm	
Principal radii of gyration	i _u	11.93	cm	about principal axes u, v in C
	i _v	9.98	cm	
Polar radii of gyration	i _p	15.55	cm	
	i _{p,M}	18.61	cm	about shear center M
Warping radius of gyration	i _{ω,M}	1.58	cm	
Cross-section weight	G	82.70	kg/m	
Cross-section perimeter	U	175.79	cm	
Torsional constant	J	56.07	cm ⁴	
Secondary torsional constant	J _s	1620.64	cm ⁴	
Location of the shear center	y _{M,0}	20.02	cm	related to absolute zero
	z _{M,0}	-1.72	cm	
	y _M	-2.62	cm	related to centroid C
	z _M	-9.88	cm	
Warping constants	I _{ω,C}	1314710.00	cm ⁶	related to centroid C
	I _{ω,M}	91265.50	cm ⁶	about shear center M
Auxiliary value for warp rotation	r _{ω,M}	-0.90		
Section moduli	S _{u,max}	474.73	cm ³	in distance 315.73 mm
	S _{u,min}	-1166.24	cm ³	in distance -128.52 mm
	S _{v,max}	614.52	cm ³	in distance 170.67 mm
	S _{v,min}	-434.11	cm ³	in distance -241.59 mm
	S _{y,max}	461.41	cm ³	in distance 318.38 mm
	S _{y,min}	-1657.73	cm ³	in distance -88.62 mm
	S _{z,max}	621.37	cm ³	in distance 173.59 mm
	S _{z,min}	-476.40	cm ³	in distance -226.41 mm
Warping section moduli	S _{ω,M,max}	2294.25	cm ⁴	in node 5
	S _{ω,M,min}	-653.97	cm ⁴	in node 6
Torsional section modulus	S _t	40.05	cm ³	
Reduction factor	λ _M	0.015394	1/cm	
Max. plastic bending moments	M _{pl,u,d}	190.66	kNm	
	M _{pl,v,d}	173.38	kNm	
Max. plastic section moduli	Z _u	892.46	cm ³	Z _u /S _u : 1.88
	Z _v	811.57	cm ³	Z _v /S _v : 1.87
Position of area bisecting axes	f _u	0.54	cm	related to centroid C
	f _v	-4.91	cm	
Plastic shear forces	V _{pl,u,d}	790.76	kN	
	V _{pl,v,d}	797.76	kN	
Plastic axial force	N _{pl,d}	2252.16	kN	
Buckling curves	BC _{y/u}		c	user-defined
	BC _{z/v}		c	

Figure 7.1: Table 2.1 *Section properties*

If the section consists of elements with different materials, the table header reads **Ideal Section Properties** inclusive of the **Reference Material** which has been defined in the *Details* tab of the *General Data* dialog box (cf chapter 4.4.2.2, page 56).

This table includes the **Effective Section Properties** if the effective cross-section design has been selected in the *General Data* tab of the *General Data* dialog (cf chapter 4.4.2.1, page 54). The section properties refer to the effective cross-section of the current load case and location x , not to the gross cross-section. This kind of analysis takes no notice of section properties that would not make sense on the basis of this model, e.g. the "effective" cross-section weight or perimeter. In the same way, no plastic cross-section properties are determined when analyzing the effective cross-section.

Cross-Sectional Area A

The total sectional area is determined from the sums of single areas for all elements $\sum A_{i,E}$ and point elements $\sum A_{j,PE}$.

$$A = \sum A_{i,E} + \sum A_{j,PE}$$

Equation 7.1

Composite Sections

If the elements of the section feature different materials, the ideal section properties are determined as follows:

$$A = \frac{\sum (A_{i,E} \cdot E_{i,E}) + \sum (A_{j,PE} \cdot E_{j,PE})}{E_{ref}}$$

Equation 7.2

where $A_{i,E}$ Area of element i
 $A_{j,PE}$ Area of point element j
 $E_{i,E}$ Elastic modulus of the material of element i
 $E_{j,PE}$ Elastic modulus of the material of point element j
 E_{ref} Elastic modulus of the reference material (cf chapter 4.4.2.2, page 56)

Shear Areas $A_y / A_z / A_u / A_v$

The shear areas can be applied to determine the shear deformations due to the shear forces V_u and V_v (in direction of the principal axes) resp. V_y and V_z (in direction of the global axes). SHAPE does not use the shear areas to determine the shear stresses, though. Those are calculated by use of the statical moments (1st moments of area).

$$A_u = \frac{I_v^2}{\int_A \left(\frac{Q_v}{t^*} \right)^2 \cdot dA} \qquad A_v = \frac{I_u^2}{\int_A \left(\frac{Q_u}{t^*} \right)^2 \cdot dA}$$

$$A_y = \frac{I_z^2}{\int_A \left(\frac{Q_z}{t^*} \right)^2 \cdot dA} \qquad A_z = \frac{I_y^2}{\int_A \left(\frac{Q_y}{t^*} \right)^2 \cdot dA}$$

Equation 7.3

where I_v resp. I_u 2nd moment of area with reference to the principal axis v resp. u
 I_z resp. I_y 2nd moment of area with reference to the global axis z resp. y
 Q_v resp. Q_u 1st moment of area with reference to the principal axis v resp. u
 Q_z resp. Q_y 1st moment of area with reference to the global axis z resp. y
 t^* Effective element thickness for shear transfer

Composite Sections

If the elements of the section feature different materials, the ideal section properties are determined as follows:

$$A_y = \frac{I_z^2}{G_{\text{ref}} \cdot \int_A \left(\frac{Q_z}{t^*} \right)^2 \cdot \frac{1}{G} \cdot dA^*} \quad A_z = \frac{I_y^2}{G_{\text{ref}} \cdot \int_A \left(\frac{Q_y}{t^*} \right)^2 \cdot \frac{1}{G} \cdot dA^*}$$

Equation 7.4

where I_z / I_y 2nd moment of area with reference to z-axis resp. y-axis
 Q_z / Q_y 1st moment of area with reference to z-axis resp. y-axis
 G_{ref} Shear modulus of the reference material
 t^* Effective width of element for shear transfer

Centroid Position $y_{C,0} / z_{C,0}$

These two table lines specify the global coordinates of the center of gravity C, with respect to the origin (y_0/z_0).

$$y_{C,0} = \frac{1}{A} \cdot \int_A y_0 \cdot dA \quad z_{C,0} = \frac{1}{A} \cdot \int_A z_0 \cdot dA$$

Equation 7.5

Moments of Inertia $I_y / I_z / I_{yz}$

The 2nd moments of area I_y and I_z as well as the centrifugal moment I_{yz} refer to the section-related axis system y,z which lies parallel to the global system y_0,z_0 through the centroid C (cf Figure 7.2).

$$I_y = \int_A z^2 \cdot dA \quad I_z = \int_A y^2 \cdot dA \quad I_{yz} = \int_A y \cdot z \cdot dA$$

Equation 7.6

Composite Sections

If the elements of the section feature different materials, the ideal section properties are determined as follows:

$$I_y = \frac{\sum (I_{y,i,E} \cdot E_{i,E}) + \sum (I_{y,j,PE} \cdot E_{j,PE})}{E_{\text{ref}}}$$

Equation 7.7

where $I_{y,i,E}$ 2nd moment of area of element i with reference to the principal axis y (sum of innate moment of inertia and parallel axis theorem component)
 $E_{i,E}$ Elastic modulus of the material of element i
 $I_{y,j,PE}$ 2nd moment of area of point element j with reference to the principal axis y (sum of innate moment of inertia and parallel axis theorem component)
 $E_{j,PE}$ Elastic modulus of the material of point element j
 E_{ref} Elastic modulus of the reference material (cf chapter 4.4.2.2, page 56)

The ideal moments of inertia I_z and I_{yz} are determined analogously for composite sections.

Inclination of Principal Axes α

The position of the principal axes u and v is defined by the angle α . This is the angle between the axis y and the axis u which is positively clockwise if the positive direction of the axis y_0 is to the right.

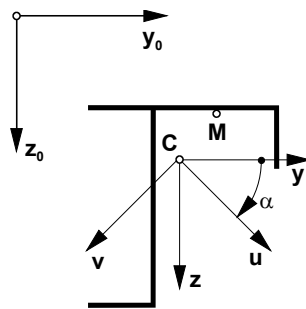

Figure 7.2: Inclination of principal axes

The angle α is determined from the following equation:

$$\tan 2\alpha = \frac{2 \cdot I_{yz}}{I_z - I_y}$$

Equation 7.8

The transformation of the principal axes can be controlled indirectly in the *Details* tab of the *General Data* dialog box (cf Figure 4.37, page 56) which can be called up via menu

Edit → **Section properties** → **General data**.

With the option to *Transform the principal axes such that I_u is always greater than I_v* , the axis u always represents the major axis, independent of the position of the section.

Principal Moments of Inertia I_u / I_v

The 2nd moments of area I_u and I_v refer to the principal axes u and v of the section.

$$I_u = I_y \cdot \cos^2 \alpha + I_z \cdot \sin^2 \alpha - I_{yz} \cdot \sin 2\alpha$$

$$I_v = I_y \cdot \sin^2 \alpha + I_z \cdot \cos^2 \alpha + I_{yz} \cdot \sin 2\alpha$$

Equation 7.9

Polar Moments of Inertia $I_p / I_{p,M}$

The polar 2nd moments of area I_p resp. $I_{p,M}$ refer to the centroid C resp. the shear center M .

$$I_p = \int_A r^2 \cdot dA = \int_A (y^2 + z^2) \cdot dA = I_y + I_z$$

$$I_{p,M} = I_p + (y_M^2 + z_M^2)$$

Equation 7.10

If there is a lateral restraint D , the polar 2nd moment of area $I_{p,D}$ is displayed instead of $I_{p,M}$.

$$I_{p,D} = I_p + (y_D^2 + z_D^2)$$

Equation 7.11

Radii of Gyration $i_y / i_z / i_{yz} / i_u / i_v / i_p / i_{p,M} / i_{\omega,M}$

The radii of gyration represent important values for the stability analyses of sections that are subject to compression. In the following general equation, the index a stands for the above-mentioned indices of the various radii of gyration.

$$i_a = \sqrt{\frac{I_a}{A}}$$

Equation 7.12

Cross-Section Weight G

The section weight is the product of the cross-sectional area A of all elements and point elements and the specific weight γ that has been defined in table 1.2 *Materials*. It is given in terms of weight per unit length of the section.

$$G = \sum (A_{i,E} \cdot \gamma_{i,E}) + \sum (A_{j,PE} \cdot \gamma_{j,PE})$$

Equation 7.13



The mass is determined with the standard gravity of 9.81 N/kg.

Cross-Section Perimeters U / U_{external} / U_{internal}

The perimeter U of the section represents the sum of the external and the internal perimeters. As the latter is zero for open sections, only the perimeter U is displayed in such cases.

Torsional Constants J / $J_{\text{St.Venant}}$ / J_{Bredt} / J_s

The torsional constant J is the sum of the torsional constants due to ST. VENANT $J_{\text{St.Venant}}$ and BREDT J_{Bredt} . The latter is zero for open sections.

$$J = J_{\text{St.Ven.}} + J_{\text{Bredt}}$$

Equation 7.14

For thin-walled sections, the Saint Venant torsional constant is determined as follows.

$$J_{\text{St.Ven.}} = \eta \cdot \left(\frac{1}{3} \cdot \sum_i l_i \cdot t_{i,i}^{*3} - 0.105 \cdot \sum_{i,f} t_{i,f}^{*4} + 0.0087 \cdot \sum_{i,f} \frac{t_{i,f}^{*8}}{l_{i,f}^4} \right)$$

Equation 7.15

- where η Correction factor for ST. VENANT torsional constant (cf Figure 4.37, page 56)
- l_i Length of element i
- $t_{i,i}^*$ Effective thickness of element i for shear transfer
- $t_{i,f}^*$ Effective thickness of element with free end i,f for shear transfer
- $l_{i,f}^*$ Length of element with free end i,f for shear transfer

The default value of the correction factor η is 1.00. It can be adjusted in the *Details* tab of the *General Data* dialog box (cf Figure 4.37, page 56).

The Bredt torsional constant of a single-cell section is determined as follows:

$$J_{\text{Bredt}} = \frac{4 \cdot A_m^2}{\int_s \frac{1}{t^*} \cdot ds}$$

Equation 7.16

- where A_m Cell area bounded by center lines of surrounding elements
- t^* Effective element thickness for shear transfer

The secondary torsional constant is determined according to the following equation:

$$J_s = \frac{l_{\omega,M}^2}{\sum_i \frac{1}{t_{i,i}^*} \cdot \sum_0^l Q_{\omega,M}^2 \cdot ds}$$

Equation 7.17

- where $l_{\omega,M}$ Warping constant
- $t_{i,i}^*$ Effective thickness for shear transfer of element i
- l_i Length of element i
- $Q_{\omega,M}$ Warping statical moment which is required to determine the shear flow due to secondary torsional moment M_{xs} (cf. chapter 7.2, page 106)

If the elements of the section feature different materials, the ideal torsional constants are determined as follows:

$$J_{\text{St.Ven.}} = \frac{\eta}{G_{\text{ref}}} \cdot \left(\frac{1}{3} \cdot \sum_i I_i \cdot t_{*i}^3 \cdot G_i - 0.105 \cdot \sum_{i,f} t_{*i,f}^4 \cdot G_{i,f} + 0.0087 \cdot \sum_{i,f} \frac{t_{*i,f}^8}{l_{i,f}} \cdot G_{i,f} \right)$$

Equation 7.18

where G_{ref} Shear modulus of the reference material (cf chapter 4.4.2.2, page 56)

G_i Shear modulus of the material of element i

$G_{i,f}$ Shear modulus of the material of element with free end i, f

$$J_{\text{Bredt}} = \frac{4 \cdot A_m^2}{G_{\text{ref}} \cdot \sum_i \frac{l_i}{t_{*i} \cdot G_i}}$$

Equation 7.19

$$J_s = \frac{I_{\omega, M}^2}{G_{\text{ref}}^2 \cdot \int_A \left(\frac{Q_{\omega, M}}{t^* \cdot G} \right)^2 \cdot dA}$$

Equation 7.20

Shear Center Location $y_{M,0} / z_{M,0} / y_M / z_M$

In the shear center M , the moment caused by the shear stress due to a shear force is zero. If the shear force acts through the shear center, the section is subjected to bending but not to torsional moments so that the member does not undergo any rotation.

Regarding doubly symmetrical sections, the shear center lies in the intersection of the axes of symmetry, i.e. coincides with the center of gravity C .

The y/z coordinates of the shear center are listed with respect to both the global origin (0/0) and the centroid C . The latter are determined as follows:

$$y_M = \frac{R_{C,z} \cdot I_{yz} - R_{C,y} \cdot I_z}{I_y \cdot I_z - I_{yz}^2}$$

$$z_M = \frac{R_{C,z} \cdot I_y - R_{C,y} \cdot I_{yz}}{I_y \cdot I_z - I_{yz}^2}$$

Equation 7.21

where $R_{C,y} = \frac{1}{6} \cdot \sum \Delta A \cdot [2 \cdot (z_s \cdot \omega_{C,s} + z_e \cdot \omega_{C,e}) + z_s \cdot \omega_{C,e} + z_e \cdot \omega_{C,s}]$

$$R_{C,z} = \frac{1}{6} \cdot \sum \Delta A \cdot [2 \cdot (y_s \cdot \omega_{C,s} + y_e \cdot \omega_{C,e}) + y_s \cdot \omega_{C,e} + y_e \cdot \omega_{C,s}]$$

In the equations of $R_{C,y}$ and $R_{C,z}$, the indices s and e characterize the start resp. end nodes of the elements. The normalized warping constants ω_c (cf chapter 7.2, page 106) are related to the center of gravity C .

If the coordinates of the shear center are transformed in the following manner, they refer to the global zero (0/0):

$$y_{M,0} = y_M + y_{C,0}$$

$$z_{M,0} = z_M + z_{C,0}$$

Equation 7.22

Warping Constants $I_{\omega,C} / I_{\omega,M}$

The warping constant is required to determine the warping stresses $\sigma_{x,M\omega}$ and τ_{MxS} . For the warping constant $I_{\omega,M}$, the normalized warping constant about the shear center M is taken into account as follows.

$$I_{\omega,M} = \int_A \omega_M^2 \cdot dA$$

Equation 7.23

If there is a lateral restraint, the warping constant $I_{\omega,D}$ about the location of this restraint D is displayed instead. The warping constants $I_{\omega,S}$, $I_{\omega,M}$, $I_{\omega,D}$ with respect to rotation about the center of gravity C, the shear center M or the lateral restraint D are defined as follows:

$$I_{\omega,C} = \frac{1}{3} \cdot \sum \Delta A \cdot (\omega_{C,s}^2 + \omega_{C,s} \cdot \omega_{C,e} + \omega_{C,e}^2)$$

$$I_{\omega,M} = I_{\omega,C} + y_M \cdot R_{C,y} - z_M \cdot R_{C,z}$$

$$I_{\omega,D} = I_{\omega,C} + y_D \cdot R_{C,y} - z_D \cdot R_{C,z}$$

Equation 7.24

The indices s and e characterize the start resp. end nodes of the elements. The normalized warping constants ω_C (cf chapter 7.2, page 106) are related to the center of gravity C. The constants $R_{C,y}$ and $R_{C,z}$ are explained beneath Equation 7.21.

Composite Sections

If the elements of the section feature different materials, the ideal warping constant $I_{\omega,C}$ is determined as follows:

$$I_{\omega,C} = \frac{1}{3 \cdot E_{\text{ref}}} \cdot \sum \Delta A \cdot (\omega_{C,s}^2 + \omega_{C,s} \cdot \omega_{C,e} + \omega_{C,e}^2) \cdot E$$

Equation 7.25

The ideal warping constants $I_{\omega,M}$ resp. $I_{\omega,D}$ are calculated as for homogenous sections, with consideration of the modified ideal auxiliary values:

$$R_{C,y} = \frac{1}{6 \cdot E_{\text{ref}}} \cdot \sum \Delta A \cdot [2 \cdot (z_s \cdot \omega_{C,s} + z_e \cdot \omega_{C,e}) + z_s \cdot \omega_{C,e} + z_e \cdot \omega_{C,s}] \cdot E$$

$$R_{C,z} = \frac{1}{6 \cdot E_{\text{ref}}} \cdot \sum \Delta A \cdot [2 \cdot (y_s \cdot \omega_{C,s} + y_e \cdot \omega_{C,e}) + y_s \cdot \omega_{C,e} + y_e \cdot \omega_{C,s}] \cdot E$$

Warp Rotation $r_{\omega,M}$

The auxiliary value for the warp rotation is determined according to the following equation:

$$r_{\omega,M} = \frac{R_{\omega,M}}{I_{\omega,M}} \quad \text{resp.}$$

$$r_{\omega,D} = \frac{R_{\omega,D}}{I_{\omega,D}} \quad \text{for a section with lateral restraint}$$

Equation 7.26

$$\text{where } R_{\omega,M} = \int_A \omega_M \cdot [(y - y_M)^2 + (z - z_M)^2] \cdot dA$$

Composite Sections

If the elements of the section feature different materials, $R_{\omega,M}$ is determined as follows:

$$R_{\omega,M} = \frac{1}{E_{\text{ref}}} \cdot \int_A \omega_M \cdot [(y - y_M)^2 + (z - z_M)^2] \cdot E \cdot dA$$

Equation 7.27

Elastic Section Moduli $S_u / S_v / S_y / S_z$

By means of the elastic section moduli, the stresses due to bending moments can be calculated. Those section moduli are related to the principal axes u and v resp. the axes y and z that lie parallel to the global system y_0 / z_0 through the centroid C .

To determine the maximum or minimum elastic section moduli, the 2nd moments of area are divided by the respective positive or negative distances of the outermost element edges from the centroid C . The distances are specified in the *Comment* column.

$$S_{u,\max/\min} = \frac{I_u}{e_{v,\max/\min}} \quad S_{v,\max/\min} = \frac{I_v}{e_{u,\max/\min}}$$

$$S_{y,\max/\min} = \frac{I_y}{e_{z,\max/\min}} \quad S_{z,\max/\min} = \frac{I_z}{e_{y,\max/\min}}$$

Equation 7.28

Composite Sections

By applying the ideal 2nd moments of area in these equations, the elastic section moduli can be determined for sections with elements that feature different materials.

Warping Section Modulus $S_{\omega,M}$

The warping elastic section modulus $S_{\omega,M}$ relates to the shear center M . It is determined as follows:

$$S_{\omega,M,\max/\min} = \frac{I_{\omega,M}}{\omega_{M,\max/\min}} \quad \text{resp.}$$

$$S_{\omega,D,\max/\min} = \frac{I_{\omega,D}}{\omega_{D,\max/\min}} \quad \text{for a section with lateral restraint}$$

Equation 7.29

where ω_M Normalized warping constant about M (cf chapter 7.2, page 106)

$I_{\omega,M}$ Warping constant (cf Equation 7.23)

The nodes of the maximum and minimum values of ω_M are stated in the *Comment* column.

Composite Sections

By applying the ideal warping constant $I_{\omega,M}$, the warping section moduli can be determined for sections with elements that feature different materials.

Torsional Section Modulus S_t

When determining the torsional section modulus, it has to be differentiated between open sections and closed sections. For open sections, the value of S_t is determined as follows:

$$S_t = \frac{J}{t_{\max}^*}$$

Equation 7.30

where t_{\max}^* Effective maximum thickness for shear transfer of all elements

For closed sections that include one or more cells, the value of S_t is calculated according to the following equation.

$$S_t = 2 \cdot A_m \cdot t_{\min}^*$$

Equation 7.31

where A_m Cell area bounded by center lines of surrounding elements

t_{\min}^* Effective minimum thickness for shear transfer of all cell elements

Section Ranges $r_y / r_z / r_{My} / r_{Mz}$

The section ranges r_y and r_z are required to calculate the ideal slenderness ratio for lateral torsional buckling analyses according to DIN 4114.

$$r_y = \frac{1}{I_y} \cdot \int_A e_z \cdot (e_y^2 + e_z^2) \cdot dA \qquad r_z = \frac{1}{I_z} \cdot \int_A e_y \cdot (e_y^2 + e_z^2) \cdot dA$$

Equation 7.32

The section ranges r_{My} and r_{Mz} represent the transformed section ranges according to the above Equation 7.32. Those are used for the FEA design in various additional modules of RSTAB and RFEM. The section ranges are determined as follows:

$$r_{My} = r_z - 2 \cdot e_{y,M} \qquad r_{Mz} = r_y - 2 \cdot e_{z,M}$$

Equation 7.33

Reduction Factor λ_M

The reduction factor is required in order to calculate the internal forces and moment due to warping.

$$\lambda_M = \sqrt{\frac{G \cdot J}{E \cdot I_{\omega,M}}} \quad \text{resp.}$$

$$\lambda_D = \sqrt{\frac{G \cdot J}{E \cdot I_{\omega,D}}} \quad \text{for a section with lateral restraint}$$

Equation 7.34

where	G	Shear modulus
	J	Torsional constant
	E	Elastic modulus
	$I_{\omega,M}$	Warping constant (cf Equation 7.23)

When splitting up the torsional moment into its components M_{xp} and M_{xs} , the reduction factor may be helpful: For small values of λ , the warping component is predominant. For large values of λ , however, the St. Venant component prevails.

Plastic Moment Capacities $M_{pl,y,d} / M_{pl,z,d} / M_{pl,u,d} / M_{pl,v,d}$

In general, the maximum plastic bending moments are determined via the area bisecting axes, i.e. without consideration of any interaction formulae.

The plastic design moment capacities are calculated from the design yield strength and the plastic section moduli.

$$M_{pl,y,d} = Z_y \cdot f_{y,d} \qquad M_{pl,z,d} = Z_z \cdot f_{y,d}$$

$$M_{pl,u,d} = Z_u \cdot f_{y,d} \qquad M_{pl,v,d} = Z_v \cdot f_{y,d}$$

Equation 7.35

where	Z_{pl}	Maximum plastic section moduli (see below)
	$f_{y,d}$	Design value of yield strength

Composite Sections

If the elements of the section feature different materials, the ideal plastic moment capacities are determined by applying the ideal maximum plastic section moduli (see below) and the design yield strength of the reference material.

$$\begin{aligned} M_{pl,y,d} &= Z_y \cdot f_{y,d,ref} & M_{pl,z,d} &= Z_z \cdot f_{y,d,ref} \\ M_{pl,u,d} &= Z_u \cdot f_{y,d,ref} & M_{pl,v,d} &= Z_v \cdot f_{y,d,ref} \end{aligned}$$

Equation 7.36

Plastic Section Moduli $Z_y / Z_z / Z_u / Z_v$

The plastic section moduli are determined by adding the absolute values of the 1st moments of area (statical moments) of the various section components about an axis which bisects the cross-sectional area.

$$\begin{aligned} Z_y &= |Q_{y,top}| + |Q_{y,bottom}| & Z_z &= |Q_{z,top}| + |Q_{z,bottom}| \\ Z_u &= |Q_{u,top}| + |Q_{u,bottom}| & Z_v &= |Q_{v,top}| + |Q_{v,bottom}| \end{aligned}$$

Equation 7.37

The plastic reserve capacities are listed in the *Comment* column. They represent the ratios of the plastic section moduli and the elastic capacities.

$$\begin{aligned} \alpha_{pl,y} &= \frac{Z_y}{S_y} & \alpha_{pl,z} &= \frac{Z_z}{S_z} \\ \alpha_{pl,u} &= \frac{Z_u}{S_u} & \alpha_{pl,v} &= \frac{Z_v}{S_v} \end{aligned}$$

Equation 7.38

$$\begin{aligned} \text{where } S_y &= \min(S_{y,max}, |S_{y,min}|) & S_z &= \min(S_{z,max}, |S_{z,min}|) \\ S_u &= \min(S_{u,max}, |S_{u,min}|) & S_v &= \min(S_{v,max}, |S_{v,min}|) \end{aligned}$$

Composite Sections

If the elements of the section feature different materials, the ideal plastic section moduli are determined via the area bisecting axes (see below). Those are calculated from the products of the areas and yield strengths of elements and point elements.

For example, the maximum ideal plastic section modulus Z_y is determined as follows:

$$Z_y = \frac{\sum (A_{i,E} \cdot |e_{f,z,i,E}| \cdot f_{y,d,i,E}) + \sum (A_{j,PE} \cdot |e_{f,z,j,PE}| \cdot f_{y,d,j,PE})}{f_{y,d,ref}}$$

Equation 7.39

where	$A_{i,E}$	Area of element i
	$e_{f,z,i,E}$	Distance of centroid of element i from area bisecting axis f_y
	$f_{y,d,i,E}$	Design yield strength of material of element i
	$A_{j,PE}$	Area of point element j
	$e_{f,z,j,PE}$	Distance of centroid of point element j from area bisecting axis f_y
	$f_{y,d,j,PE}$	Design yield strength of material of point element j
	$f_{y,d,ref}$	Design yield strength of reference material (cf chapter 4.4.2.2, page 56)

Plastic Shear Areas $A_{pl,y} / A_{pl,z} / A_{pl,u} / A_{pl,v}$

The plastic shear areas are determined as follows.

$$A_{pl,y} = \sum [t_{i,E}^* \cdot (y_{e,i,E} - y_{s,i,E})] \quad A_{pl,z} = \sum [t_{i,E}^* \cdot (z_{e,i,E} - z_{s,i,E})]$$

$$A_{pl,u} = \sum [t_{i,E}^* \cdot (u_{e,i,E} - u_{s,i,E})] \quad A_{pl,v} = \sum [t_{i,E}^* \cdot (v_{e,i,E} - v_{s,i,E})]$$

Equation 7.40

where $t_{i,E}^*$ Effective thickness of element i
 $y_{e,i,E}$ resp. $z_{e,i,E}$ Distance of end of element i from axis z resp. y
 $y_{s,i,E}$ resp. $z_{s,i,E}$ Distance of start of element i from axis z resp. y

Composite Sections

If the elements of the section feature different materials, the ideal shear areas are calculated with consideration of the reference material. For example, the ideal shear area $A_{pl,z}$ is determined as follows.

$$A_{pl,z} = \frac{1}{f_{y,d,ref}} \int_0^s t^* \cdot f_{y,d} \cdot dz$$

$$A_{pl,z} = \frac{1}{f_{y,d,ref}} \cdot \sum [t_{i,E}^* \cdot (z_{e,i,E} - z_{s,i,E}) \cdot f_{y,d,i,E}]$$

Equation 7.41

where $f_{y,d,i,E}$ Design yield strength of material of element i
 $f_{y,d,ref}$ Design yield strength of reference material (cf chapter 4.4.2.2, page 56)

Area Bisecting Axes Location $f_{y,0} / f_{z,0} / f_u / f_v$

When calculating the plastic section properties (cf Figure 4.33, page 53), the area bisecting axes are determined iteratively. They are illustrated by dotted lines in the section graphics. The intersection point of the axes $f_{y,0}$ and $f_{z,0}$ is related to the global zero (0/0), the intersection point of the axes f_u and f_v to the center of gravity C .

The inclination of the area bisecting axes f_u and f_v corresponds to the principal axes inclination α .

Plastic Shear Capacities $V_{pl,y,d} / V_{pl,z,d} / V_{pl,u,d} / V_{pl,v,d}$

The plastic shear capacities are calculated from the shear areas and the design value of the yield strength $f_{y,d}$.

$$V_{pl,y,d} = \frac{A_{pl,y} \cdot f_{y,d}}{\sqrt{3}} \quad V_{pl,z,d} = \frac{A_{pl,z} \cdot f_{y,d}}{\sqrt{3}}$$

$$V_{pl,u,d} = \frac{A_{pl,u} \cdot f_{y,d}}{\sqrt{3}} \quad V_{pl,v,d} = \frac{A_{pl,v} \cdot f_{y,d}}{\sqrt{3}}$$

Equation 7.42

Composite Sections

If the elements of the section feature different materials, the ideal plastic shear capacities are determined with the yield strength of the reference material.

Plastic Axial Force Capacity $N_{pl,d}$

The limiting internal force $N_{pl,d}$ represents the sum of the products of areas and design yield strengths of all elements and point elements.

$$N_{pl,d} = \sum (A_{i,E} \cdot f_{y,d,i,E}) + \sum (A_{j,PE} \cdot f_{y,d,j,PE})$$

Equation 7.43

- where $A_{i,E}$ Area of element i
- $f_{y,d,i,E}$ Design yield strength of material of element i
- $A_{j,PE}$ Area of point element j
- $f_{y,d,j,PE}$ Design yield strength of material of point element j

Buckling Curves $BC_{y/u}$ / $BC_{z/v}$

For buckling analyses, every section has to be classified to specific buckling curves with respect to the principal axes y and z respectively u and v (cf DIN 18 800 Part 2, Table 5 or EN 1993-1-1, Table 6.2).

The buckling curves mainly depend on the shape of the section. As the program cannot allocate the buckling curves automatically for user-defined sections, the buckling curves $BC_{y/u}$ and $BC_{z/v}$ are displayed which have been defined in the *Details* tab of the *General Data* dialog box, cf chapter 4.4.2.2 on page 57.

7.2 Statical Moments

The second results table includes the statical moments Q_y and Q_z (1st moments of area) as well as the normalized warping ordinates ω_M and the warping statical moments $Q_{\omega M}$.

The distribution of the statical moments and warping ordinates can also be displayed in the graphics.

Element No.	Node No.	Distance s [mm]	Stat. moments Qu [cm³]	Stat. moments Qv [cm³]	Qu,max [cm³] s [mm]	Qv,max [cm³] s [mm]	Warping ωM [cm²]	SwM [cm⁴]
1	1	0.00	0.00	0.00	-18.91	-150.94	-27.93	0.00
		25.00	-8.33	-79.70	50.00	50.00	-23.62	90.22
		50.00	-18.91	-150.94			-19.32	165.37
2	2	0.00	-486.05	-20.95	-511.49	-61.89	6.53	274.34
		200.00	-435.64	-61.41	80.00	180.00	6.86	140.48
		400.00	0.00	0.00			7.19	0.00
3	2	0.00	367.23	-328.54	367.23	-343.65	6.53	-23.93
		96.50	252.84	-328.46	0.00	38.60	23.15	-224.42
		193.00	102.36	-199.23			39.78	-649.54
4	5	0.00	102.36	-199.23	102.36	-199.23	39.78	-649.54
		46.50	35.02	-100.97	0.00	0.00	-49.89	-616.64
		93.00	0.00	0.00			-139.56	0.00
5	7	0.00	-18.91	-150.94	-18.91	-150.94	-19.32	165.37
		10.00	-18.91	-150.94	0.00	0.00	-17.59	165.37
		20.00	-18.91	-150.94			-15.87	165.37
6	8	0.00	-18.91	-150.94	-118.82	-349.39	-15.87	165.37
		65.00	-61.64	-279.03	130.00	130.00	-4.67	258.85
		130.00	-118.82	-349.39			6.53	250.41

Figure 7.3: Table 2.2 Statical moments and warping statical moments

If the section consists of elements with different materials, the table header reads **Ideal Property Distribution** inclusive of the **Reference Material** which has been defined in the *Details* tab of the *General Data* dialog box (cf chapter 4.4.2.2, page 56).



Via the [Filter] button in the table toolbar, the types of results can be selected that are to be displayed in this table.

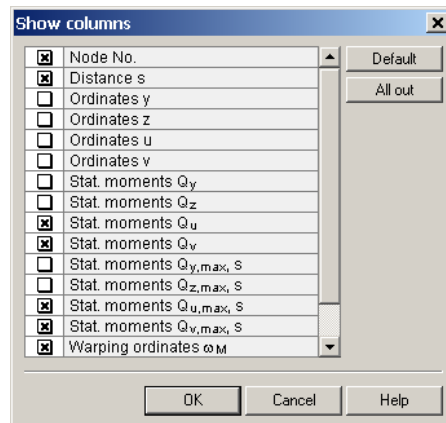

Figure 7.4: Dialog box *Show Columns*

Element Number

All statical moments are listed by elements.

Node Number

The statical moments are listed at the start and end nodes of each element. Additionally, the values of the following columns are also shown for all element centers.

Distance s

This value indicates the distance of a particular location from the start node of the element.

Ordinates y, z, u, v

In these four columns, the ordinates of all element locations are listed. They are related to the global axes y and z or the principal axes u and v, with reference to the centroid C.

Statical Moments $Q_y / Q_z / Q_u / Q_v$

The statical moments (1st moments of area) are listed with reference to the global axes y and z or the principal axes u and v of the section. The statical moment is defined as the product of dA and the distance from its centroid to a reference axis that lies in the plane of the section.

$$Q_y = \int_A z \cdot dA \qquad Q_z = \int_A y \cdot dA$$

$$Q_u = \int_A v \cdot dA \qquad Q_v = \int_A u \cdot dA$$

Equation 7.44

where z resp. y Distance from the elemental area centroid to axis y resp. z
 v resp. u Distance from the elemental area centroid to axis u resp. v

The statical moments are required to determine the shear stresses due to the shear forces V_y and V_z . The element direction, which is defined by the order of the start and end nodes, has an effect on the sign of the statical moments.



Composite Sections

If the elements of the section feature different materials, the ideal statical moments are determined as follows:

$$Q_y = \frac{1}{E_{\text{ref}}} \cdot \int_A z \cdot E \cdot dA \quad Q_z = \frac{1}{E_{\text{ref}}} \cdot \int_A y \cdot E \cdot dA$$

Equation 7.45

where E_{ref} Elastic modulus of the reference material (cf chapter 4.4.2.2, page 56)

The ideal statical moments Q_u and Q_v are determined analogously.

Maximum Statical Moments $Q_{y,\text{max}}$ / $Q_{z,\text{max}}$ / $Q_{u,\text{max}}$ / $Q_{v,\text{max}}$

In these four columns, the maximum statical moment (top value) and its location (second value) can be read for each element. The location s represents the distance of the maximum value from the start node of the element.

Warping Ordinates ω_M

The normalized warping constants ω_M about the shear center M are geometrical quantities. They are required to determine the stresses $\sigma_{x,M\omega}$ and τ_{Mxs} caused by warping restraint. For thin-walled, open sections, the warping ordinates are defined as follows.

$$\omega_M = \int_s r_M \cdot ds$$

Equation 7.46

where r_M Perpendicular distance of the element from shear center M



With warp-free sections, the normalized warping ordinates are zero. If there is a lateral restraint, the warping ordinates ω_D about the point of rotation D are listed.

Warping Statical Moments $Q_{\omega,M}$

The warping statical moment is determined from the normalized warping constants ω_M .

$$Q_{\omega,M} = \int_A \omega_M \cdot dA$$

Equation 7.47

where ω_M Warping constant of the elemental area about shear center M

The warping statical moments are zero with warp-free sections. If there is a lateral restraint, the warping statical moments $Q_{\omega,D}$ about the point of rotation D are listed.

Composite Sections

If the elements of the section feature different materials, the ideal warping statical moment is determined as follows:

$$Q_{\omega,M} = \frac{1}{E_{\text{ref}}} \cdot \int_A \omega_M \cdot E \cdot dA$$

Equation 7.48

where E_{ref} Elastic modulus of reference material (cf chapter 4.4.2.2, page 56)

Cell Areas A_m

For closed sections, the areas of the cells are specified for every element. They are determined from the thicknesses and the locations of the respective elements.

With single-cell sections, A_m is identical to the cell area bounded by the center lines of the surrounding elements.

7.3 Normal Stresses σ_x

In this results table, the various normal stresses σ_x are listed for every *Location x* that has been defined in table 1.7 *Forces and moments* (cf chapter 5.7, page 84).

The sign rules are illustrated in Figure 5.33 on page 86.

This table lists the stresses of the **Effective Section** if the effective cross-section design has been chosen in the *General* tab of the *General Data* dialog box (cf chapter 4.4.2.1, page 54).

The *Extremes* can be read at the end of the list for each location *x*.

The list is concluded by the overall maximum and minimum stresses $\Sigma \sigma_x$ of all locations *x*.

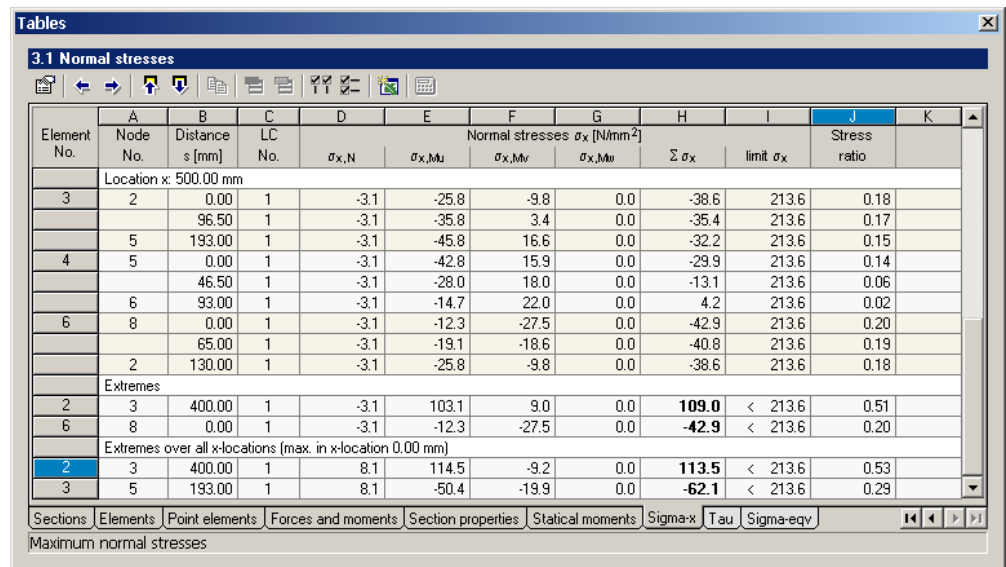

Element No.	A Node No.	B Distance s [mm]	C LC No.	Normal stresses σ_x [N/mm ²]				$\Sigma \sigma_x$	limit σ_x	Stress ratio
				D $\sigma_{x,N}$	E σ_{x,M_u}	F σ_{x,M_v}	G σ_{x,M_w}			
Location x: 500.00 mm										
3	2	0.00	1	-3.1	-25.8	-9.8	0.0	-38.6	213.6	0.18
		96.50	1	-3.1	-35.8	3.4	0.0	-35.4	213.6	0.17
	5	193.00	1	-3.1	-45.8	16.6	0.0	-32.2	213.6	0.15
4	5	0.00	1	-3.1	-42.8	15.9	0.0	-29.9	213.6	0.14
		46.50	1	-3.1	-28.0	18.0	0.0	-13.1	213.6	0.06
	6	93.00	1	-3.1	-14.7	22.0	0.0	4.2	213.6	0.02
6	8	0.00	1	-3.1	-12.3	-27.5	0.0	-42.9	213.6	0.20
		65.00	1	-3.1	-19.1	-18.6	0.0	-40.8	213.6	0.19
	2	130.00	1	-3.1	-25.8	-9.8	0.0	-38.6	213.6	0.18
Extremes										
2	3	400.00	1	-3.1	103.1	9.0	0.0	109.0	< 213.6	0.51
6	8	0.00	1	-3.1	-12.3	-27.5	0.0	-42.9	< 213.6	0.20
Extremes over all x-locations (max. in x-location 0.00 mm)										
2	3	400.00	1	8.1	114.5	-9.2	0.0	113.5	< 213.6	0.53
3	5	193.00	1	8.1	-50.4	-19.9	0.0	-62.1	< 213.6	0.29

Figure 7.5: Table 3.1 *Normal stresses*

Element Number

For every location *x*, the normal stresses are listed by element numbers. Stresses in point elements are not covered by the analysis.

Node Number

The normal stresses are listed at the start and end nodes of each element. Additionally, the values of the following columns are also shown for all element centers.

Distance s

This value indicates the distance of a particular location from the start node of the element.

LC Number

In this column, the number of the respective load case is shown.

$\sigma_{x,N}$

$$\sigma_{x,N} = \frac{N}{A}$$

Equation 7.49

where N Axial force
 A Cross-sectional area

σ_{x,M_u}

$$\sigma_{x,M_u} = \frac{M_u}{I_u} \cdot e_v$$

Equation 7.50

where M_u Bending moment about principal axis u
 I_u Principal moment of inertia (2nd moment of area) about axis u
 e_v Distance from center of gravity in direction of principal axis v

The reference of the internal forces is controlled in the *Details* tab of the *General Data* dialog box (cf. Figure 4.37, page 56) which can be called up via menu

Edit → **Section properties** → **General data**.

 σ_{x,M_v}

$$\sigma_{x,M_v} = -\frac{M_v}{I_v} \cdot e_u$$

Equation 7.51

where M_v Bending moment about principal axis v
 I_v Principal moment of inertia (2nd moment of area) about axis v
 e_u Distance from center of gravity in direction of principal axis u



Shear Wall Sections

The negative sign in Equation 7.51 results from the correlation of the internal forces to the RSTAB or RFEM program. A positive moment effects tensile stresses in the strained fiber of the beam, i.e. the stresses are positive. This RSTAB convention was transferred to SHAPE, too, in order to obtain consistent signs in e.g. STEEL and SHAPE after having imported the internal forces. Thus, unit moments might be useful to check on the effects of the signs.

For shear wall sections, the normal stresses due to the bending moments M_u and M_v are calculated as follows.

$$\sigma_{x,M_u} = \frac{(I_v \cdot M_u + I_{uv} \cdot M_v) \cdot e_v}{I_u \cdot I_v - I_{uv}^2} \quad \sigma_{x,M_v} = \frac{(I_u \cdot M_v + I_{uv} \cdot M_u) \cdot e_u}{I_u \cdot I_v - I_{uv}^2}$$

Equation 7.52

where I_u, I_v, I_{uv} 2nd moments of area about total center of gravity
 e_u, e_v Distances from centroid C_i of partial section i

 σ_{x,M_ω}

$$\sigma_{x,M_\omega} = -\frac{M_\omega}{I_{\omega,M}} \cdot \omega_M$$

Equation 7.53

where M_ω Warping bimoment
 $I_{\omega,M}$ Warping constant about shear center M
 ω_M Warping constant of the elemental area about shear center M

If there is a lateral restraint, the warping stresses about the point of rotation D are listed. Those are determined with the values of $I_{\omega,D}$ and ω_D .

 $\Sigma \sigma_x$

In this column, the individual components of the normal stresses are added.

$$\Sigma \sigma_x = \sigma_{x,N} + \sigma_{x,M_u} + \sigma_{x,M_v} + \sigma_{x,M_\omega}$$

Equation 7.54

Limit σ_x

This column lists the allowable normal stresses of each material as defined e.g. in column F of table 1.2 (cf Figure 5.10, page 68).

Stress Ratio

The last column contains the ratios of existing stresses to limit stresses. Thus, the user is able to quickly check on the utilizations at the various locations x of the section.

Via the button [Show columns], the stresses due to the corresponding moments M_y and M_z (resp. M_u and M_v) can be activated. In a specific dialog box, the transformed moments are also accessible.

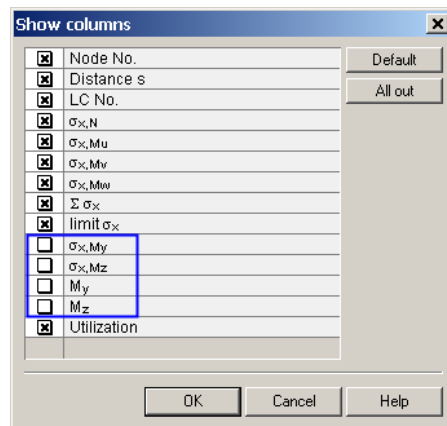

Figure 7.6: Dialog box *Show columns*

$$\sigma_{x,My} / \sigma_{x,Mz}$$

$$\sigma_{x,My} = \frac{M_y}{I_y} \cdot e_z \qquad \sigma_{x,Mz} = -\frac{M_z}{I_z} \cdot e_y$$

Equation 7.55

- where M_y / M_z Bending moment about section-related global axis y resp. z
- I_y / I_z Principal moment of inertia (2nd moment of area) about axis y resp. z
- e_z / e_y Distance from center of gravity in direction of global axis z resp. y



It is possible to select specific results via the filter function. The following dialog box appears.

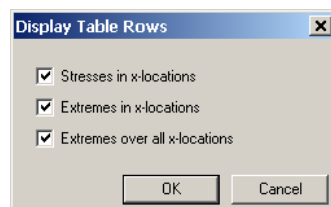

Figure 7.7: Dialog box *Display Table Rows*

Composite Sections

If the elements of the section feature different materials, the stresses are independent of the selected reference material. Internally, this is effectuated by multiplying the normal stresses of element i by E_i / E_{ref} , i.e. the ratio of the elastic moduli of element i and of the reference material.

7.4 Shear Stresses τ

In this results table, the various shear stresses τ are listed for every *Location x* that has been defined in table 1.7 *Forces and moments* (cf chapter 5.7, page 84).

The *Extremes* can be read at the end of the list for each location *x*. The list is concluded by the overall maximum shear stresses $|\Sigma \tau|$ of all locations *x*.

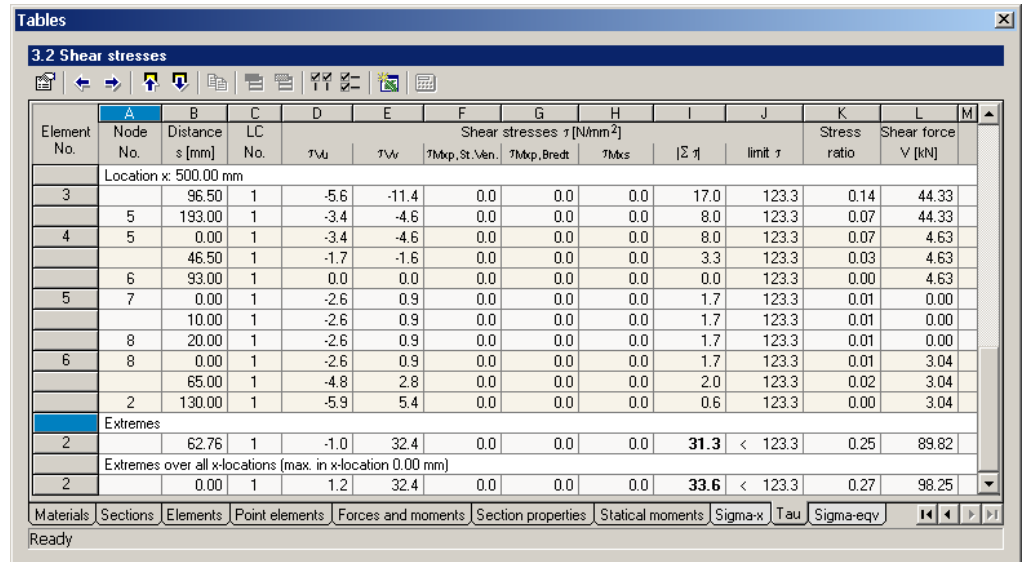

Element No.	Node No.	Distance s [mm]	LC No.	τ_{Vu}	τ_{Vv}	$\tau_{Mxp, St Ven}$	$\tau_{Mxp, Bredt}$	τ_{Mxs}	$ \Sigma \tau $	limit τ	Stress ratio	Shear force V [kN]
Location x: 500.00 mm												
3	5	193.00	1	-3.4	-4.6	0.0	0.0	0.0	8.0	123.3	0.07	44.33
4	5	0.00	1	-3.4	-4.6	0.0	0.0	0.0	8.0	123.3	0.07	4.63
		46.50	1	-1.7	-1.6	0.0	0.0	0.0	3.3	123.3	0.03	4.63
		93.00	1	0.0	0.0	0.0	0.0	0.0	0.0	123.3	0.00	4.63
5	7	0.00	1	-2.6	0.9	0.0	0.0	0.0	1.7	123.3	0.01	0.00
		10.00	1	-2.6	0.9	0.0	0.0	0.0	1.7	123.3	0.01	0.00
		20.00	1	-2.6	0.9	0.0	0.0	0.0	1.7	123.3	0.01	0.00
6	8	0.00	1	-2.6	0.9	0.0	0.0	0.0	1.7	123.3	0.01	3.04
		65.00	1	-4.8	2.8	0.0	0.0	0.0	2.0	123.3	0.02	3.04
		130.00	1	-5.9	5.4	0.0	0.0	0.0	0.6	123.3	0.00	3.04
Extremes												
2		62.76	1	-1.0	32.4	0.0	0.0	0.0	31.3	< 123.3	0.25	89.82
Extremes over all x-locations (max. in x-location 0.00 mm)												
2		0.00	1	1.2	32.4	0.0	0.0	0.0	33.6	< 123.3	0.27	98.25

Figure 7.8: Table 3.2 *Shear stresses*

Element Number

For every location *x*, the shear stresses are listed by element numbers. Stresses in point elements are not covered by the analysis.

Node Number

The shear stresses are listed at the start and end nodes of each element. Additionally, the values of the following columns are also shown for all element centers.

Distance s

This value indicates the distance of a particular location from the start node of the element.

LC Number

In this column, the number of the respective load case is shown.

τ_{Vu}

$$\tau_{Vu} = -\frac{V_u \cdot Q_v}{I_v \cdot t^*}$$

Equation 7.56

- where V_u Shear force in direction *u*
- Q_v Statical moment (1st moment of area) related to axis *v*
- I_v Principal moment of inertia (2nd moment of area) about axis *v*
- t^* Effective element thickness for shear transfer

τ_{Vv}

$$\tau_{Vv} = -\frac{V_v \cdot Q_u}{I_u \cdot t^*}$$

Equation 7.57

where V_v Shear force in direction v
 Q_u Statical moment (1st moment of area) related to axis u
 I_u Principal moment of inertia (2nd moment of area) about axis u
 t^* Effective element thickness for shear transfer

For the shear stresses of non-coherent shear wall sections, see equation Equation 7.78 in chapter 7.9 on page 126.

 $\tau_{M_{xp,St.Venant}}$

To determine the shear stresses due to primary torsion, the torsional moment M_{xp} is split up into its St. Venant component $M_{xp,St.Ven.}$ and its Bredt component $M_{xp,Bredt}$.

$$M_{xp,St.Ven.} = M_{xp} \cdot \frac{J_{St.Ven.}}{J} \quad M_{xp,Bredt} = M_{xp} \cdot \frac{J_{Bredt}}{J}$$

Equation 7.58

where M_{xp} Primary torsional moment
 $J_{St.Ven.}$ St. Venant torsional constant
 J_{Bredt} Bredt torsional constant
 J Total torsional constant (i.e. sum of $J_{St.Ven.}$ and J_{Bredt})

For thin-walled sections, the torsional shear stress due to St. Venant's theory are linearly variable over the element thickness, i.e. zero in the element center line to the extremum at the element edge. In these table columns, only the extrema of the shear stresses at the element edges are listed.

$$\tau_{M_{xp,St.Ven.}} = \frac{M_{xp,St.Ven.}}{J_{St.Ven.}} \cdot t^*$$

Equation 7.59

where $M_{xp,St.Ven.}$ St. Venant component of the primary torsional moment
 $J_{St.Ven.}$ St. Venant torsional constant
 t^* Effective element thickness for shear transfer

 $\tau_{M_{xp,Bredt}}$

Concerning closed sectional parts with cells, the torsional shear stresses due to Bredt's theory are calculated as follows.

$$\tau_{M_{xp,Bredt}} = \frac{M_{xp,Bredt}}{2 \cdot A_m \cdot t^*}$$

Equation 7.60

where $M_{xp,Bredt}$ Bredt component of the primary torsional moment
 A_m Cell area bounded by center lines of surrounding elements
 t^* Effective element thickness for shear transfer

For sections that consist of several cells, the torsional moment is allocated as follows.

$$M_{xp,i} = M_{xp} \cdot \frac{A_{m,i}}{A_m}$$

Equation 7.61

If an element represents the web between two neighboring cells, the shear flow directions of the respective cells sharing the common element are opposed when the section is subjected to a torsional moment. Thus, the shear stresses due to torsion are rather small there.

$\tau_{M_{xs}}$

The shear stresses due to the secondary torsional moment M_{xs} are determined as follows.

$$\tau_{M_{xs}} = -\frac{M_{xs} \cdot Q_{\omega,M}}{I_{\omega,M} \cdot t^*}$$

Equation 7.62

where	M_{xs}	Secondary torsional moment
	$Q_{\omega,M}$	Warping statical moment (cf chapter 7.2, page 106)
	$I_{\omega,M}$	Warping constant about shear center M (cf chapter 7.1, page 99)
	t^*	Effective element thickness for shear transfer

If there is a lateral restraint, the shear stresses about the point of rotation D are listed. Those are determined with the values of $Q_{\omega,D}$ and $I_{\omega,D}$.

For the shear stresses of non-coherent shear wall sections, see Equation 7.78 in chapter 7.9 on page 126.

$|\Sigma \tau|$

In this column, the individual components of the shear stresses are added. As for the share of St. Venant torsional stresses, the sign will be applied that increases the absolute value of the sum.

$$\Sigma \tau = \tau_{Vu} + \tau_{Vv} \pm \tau_{Mxp,St.Ven.} + \tau_{Mxp,Bredt} + \tau_{M_{xs}}$$

Equation 7.63

Limit τ

This column lists the allowable shear stresses of each material as defined e.g. in column G of table 1.2 (cf Figure 5.10, page 68).

Stress Ratio

In this column, the ratios of existing stresses to limit stresses are listed. Thus, the user is able to quickly check on the utilizations at the various locations x of the section.

Shear Force V

The last column contains the integrals of the shear forces in all elements due to the shear stresses. The resulting shear forces of each element are determined as follows:

$$V = |\tau \cdot t^* \cdot l|$$

Equation 7.64

where	τ	Shear stresses in element
	t^*	Effective element thickness
	l	Element length

In the graphics, these integrals of each element can be activated via menu

Results → Shear forces.

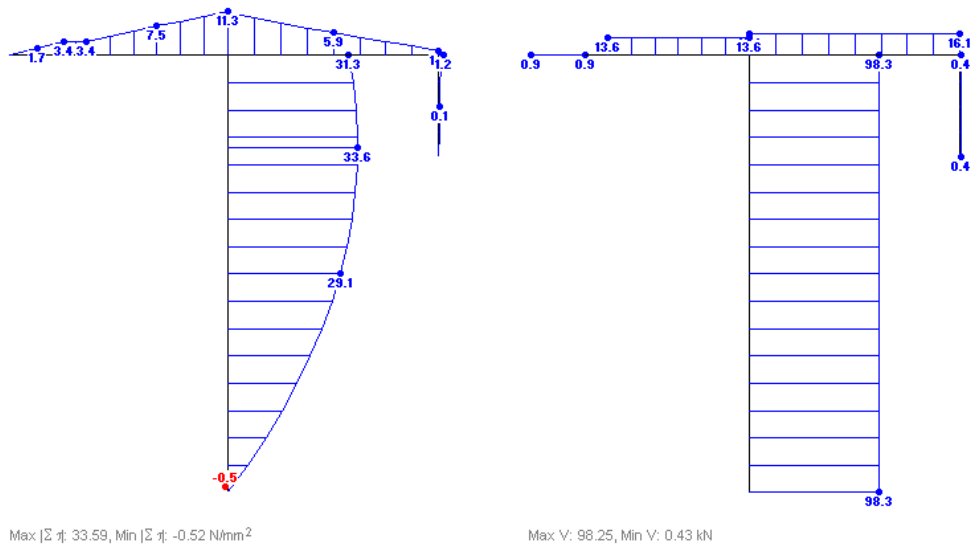

Figure 7.9: Shear stresses (left) and shear forces as integrals (right)

The shear stresses due to the primary torsional moment $M_{xp,St.Ven.}$ are not considered in this integration for open cross-sections, however. It would result in zero values when integrating over both the element lengths and element thicknesses.



Via the button [Show columns], the shear stresses due to the corresponding forces V_y and V_z (resp. V_u and V_v) can be activated. In a specific dialog box, the transformed shear forces are also accessible.

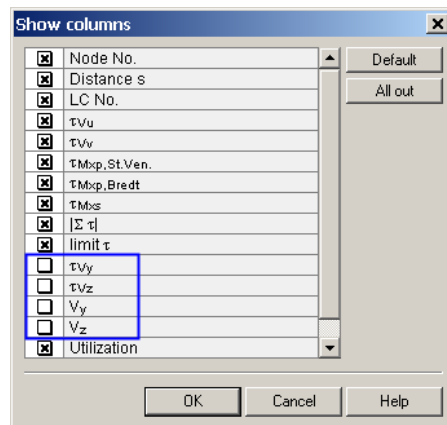

Figure 7.10: Dialog box *Show columns*

$$\tau_{Vy} / \tau_{Vz}$$

$$\tau_{Vy} = -\frac{V_y \cdot Q_z}{I_z \cdot t^*} \qquad \tau_{Vz} = -\frac{V_z \cdot Q_y}{I_y \cdot t^*}$$

Equation 7.65

- where V_y / V_z Shear force in section-related global direction y resp. z
- Q_z / Q_y Statical moment (1st moment of area) related to axis z resp. y
- I_z / I_y Principal moment of inertia (2nd moment of area) about axis z resp. y
- t^* Effective element thickness for shear transfer



Composite Sections

It is possible to select specific results via the filter function. The button as seen to the left calls up the dialog box *Display Table Rows* (cf Figure 7.7, page 109).

If the elements of the section feature different materials, the stresses are independent of the selected reference material. Internally, this is effectuated by multiplying the shear stresses of element *i* by G_i/G_{ref} i.e. the ratio of the shear moduli of element *i* and of the reference material.

7.5 Equivalent Stresses σ_{eqv}

In this table, the equivalent stresses σ_{eqv} and stress ratios are listed for every *Location x* that has been defined in table 1.7 *Forces and moments*.

The *Extremes* can be read at the end of the list for each location *x*. The list is concluded by the overall maximum stresses σ_{eqv} of all locations *x*.

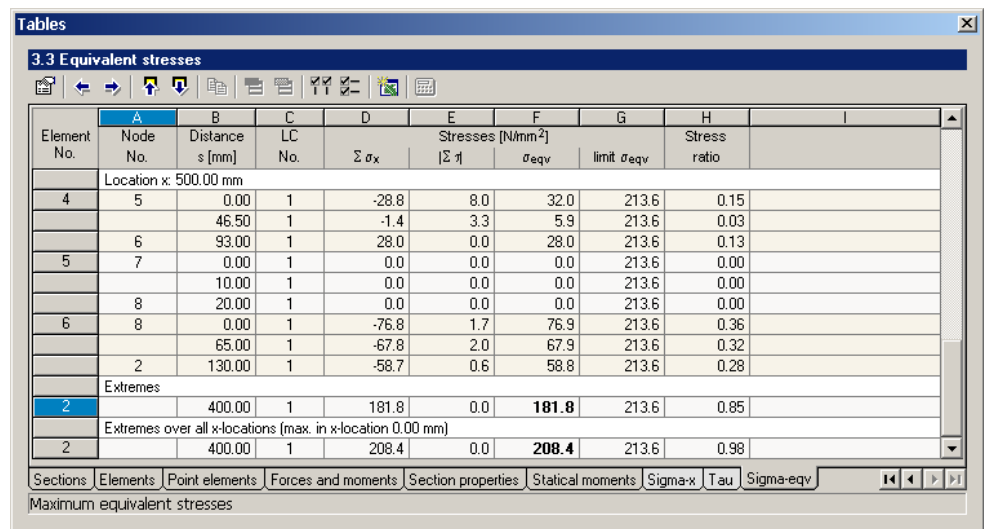

Element No.	Location x: 500.00 mm			Stresses [N/mm ²]					Stress ratio
	A Node No.	B Distance s [mm]	C LC No.	D $\Sigma \sigma_x$	E $ \Sigma \tau $	F σ_{eqv}	G limit σ_{eqv}		
4	5	0.00	1	-28.8	8.0	32.0	213.6	0.15	
		46.50	1	-1.4	3.3	5.9	213.6	0.03	
5	6	93.00	1	28.0	0.0	28.0	213.6	0.13	
	7	0.00	1	0.0	0.0	0.0	213.6	0.00	
6		10.00	1	0.0	0.0	0.0	213.6	0.00	
	8	20.00	1	0.0	0.0	0.0	213.6	0.00	
2	8	0.00	1	-76.8	1.7	76.9	213.6	0.36	
		65.00	1	-67.8	2.0	67.9	213.6	0.32	
Extremes	2	130.00	1	-58.7	0.6	58.8	213.6	0.28	
	2	400.00	1	181.8	0.0	181.8	213.6	0.85	
Extremes over all x-locations (max. in x-location 0.00 mm)									
2	400.00	1	208.4	0.0	208.4	213.6	0.98		

Figure 7.11: Table 3.3 *Equivalent stresses*

Element Number

For every location *x*, the stresses are listed by element numbers. Stresses in point elements are not covered by the analysis.

Node Number

The stresses are listed at the start and end nodes of each element and at all element centers.

Distance s

This value indicates the distance of a particular location from the start node of the element.

LC Number

In this column, the number of the respective load case is shown.

$\Sigma \sigma_x$

This column represents the sums of all normal stresses as shown in column H of table 3.1 *Normal stresses* (cf Figure 7.5, page 107).

$|\Sigma \tau|$

This column represents the absolute values of the sums from all shear stresses as they are listed in column I of table 3.2 *Shear stresses* (cf Figure 7.8, page 110).

σ_{eqv}

The equivalent stresses are determined with consideration of the yield criteria specified in the *Details* tab of the *General Data* dialog box (cf chapter 4.4.2.2, page 57).

$$\sigma_{eqv} = \sqrt{(\Sigma \sigma_x)^2 + f \cdot (\Sigma \tau)^2}$$

Equation 7.66

where f Factor to account for shear stresses



For the weld design, please note that SHAPE covers the planar state of stresses. Thus, the shear stresses of longitudinal seams of welds $\tau_{||}$ have to be taken into account additionally.

Limit σ_{eqv}

In this column, the existing equivalent stresses are compared to the allowable equivalent stress of the material as defined e.g. in column H of table 1.2 (cf Figure 5.10, page 68).

Stress Ratio

The last column contains the ratios of existing stresses to limit stresses. Thus, the user is able to quickly check on the utilizations at the various locations x of the section.



Via the button [Show columns], the transformed moments M_y and M_z (resp. M_u and M_v) and shear forces V_y and V_z (resp. V_u and V_v) can be activated in a specific dialog box.

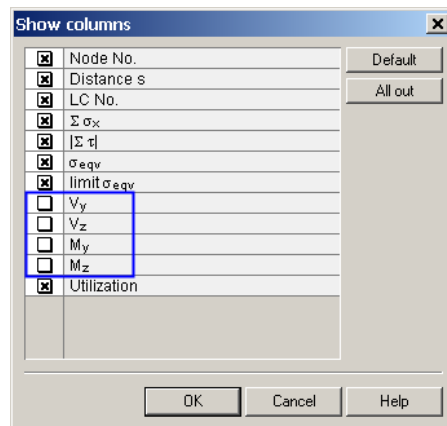

Figure 7.12: Dialog box *Show columns*



It is possible to select specific results via the filter function. The button as seen to the left calls up the dialog box *Display Table Rows* (cf Figure 7.7, page 109).

7.6 Plastic Capacity

If the plastic capacity design has been enabled in the *General Data* dialog box, the results table 4.1 *Plastic capacity* is presented after the analysis.



Column J with the enlargement factor α_{plastic} represents the most important column of this table. If all values are **greater** than 1.0, the plastic design is verified.

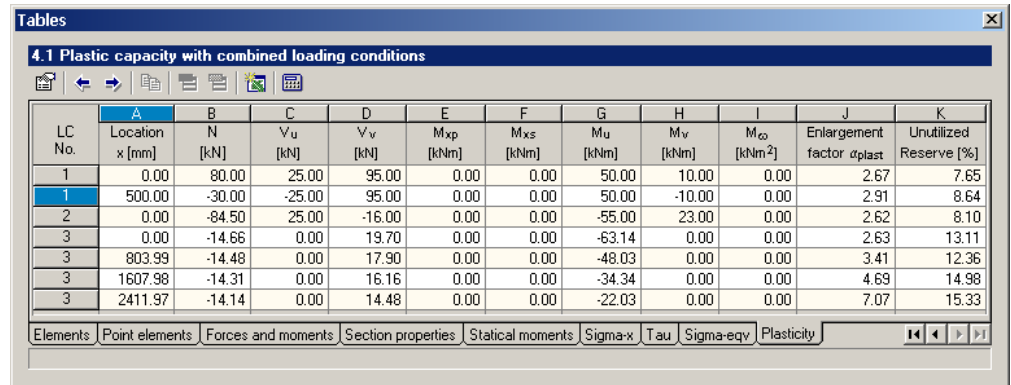

LC No.	A Location x [mm]	B N [kN]	C V _u [kN]	D V _v [kN]	E M _{xp} [kNm]	F M _{xs} [kNm]	G M _u [kNm]	H M _v [kNm]	I M _ω [kNm ²]	J Enlargement factor α _{plast}	K Unused Reserve [%]
1	0.00	80.00	25.00	95.00	0.00	0.00	50.00	10.00	0.00	2.67	7.65
1	500.00	-30.00	-25.00	95.00	0.00	0.00	50.00	-10.00	0.00	2.91	8.64
2	0.00	-84.50	25.00	-16.00	0.00	0.00	-55.00	23.00	0.00	2.62	8.10
3	0.00	-14.66	0.00	19.70	0.00	0.00	-63.14	0.00	0.00	2.63	13.11
3	803.99	-14.48	0.00	17.90	0.00	0.00	-48.03	0.00	0.00	3.41	12.36
3	1607.98	-14.31	0.00	16.16	0.00	0.00	-34.34	0.00	0.00	4.69	14.98
3	2411.97	-14.14	0.00	14.48	0.00	0.00	-22.03	0.00	0.00	7.07	15.33

Figure 7.13: Table 4.1 *Plastic capacity*

LC Number

The results of the plastic capacity design are listed by load cases.

Location x

The results are stated for the combined loading conditions of every *Location x* that has been defined in table 1.7 *Forces and moments* (cf chapter 5.7, page 84).

Internal Forces N / V_u / V_v / M_{xp} / M_{xs} / M_u / M_v / M_ω

In these eight columns, the internal forces and moments are imported from table 1.7 *Forces and moments* (cf chapter 5.7, page 84).

Enlargement Factor α_{plastic}

The enlargement factor α implies that the plastic capacity of the section is attained if all internal forces and moments of the respective location *x* are uniformly multiplied with it.

Any combination of internal forces as a result of the plastic analysis can be described by the following vector.

$$F = \{N, M_u, M_v, M_\omega, V_u, V_v, M_{xp}, M_{xs}\}$$

Equation 7.67

For the plastic design of this vector, a constant relationship of its components is assumed. Thus, the vector *F* of the internal forces is extended to the yield area by the enlargement factor α . This factor is determined as the maximum of a linear optimization using a revised simplex algorithm. Depending on the yield criteria (cf chapter 4.4.2.2, page 57), the equation for the equivalent stress (cf Equation 7.66) results in an ellipse which can be approximated by an octagon during a linear optimization process.

Yield Criteria according to von Mises

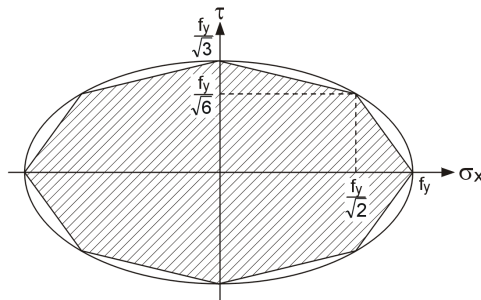

Yield Criteria according to Tresca

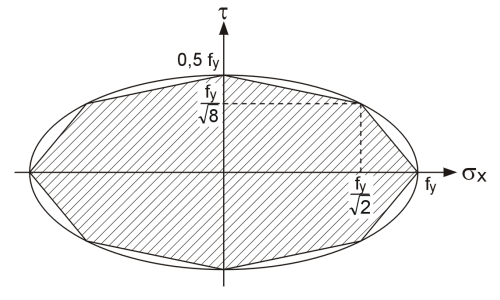

Figure 7.14: Linear optimization of the yield criteria

The section is discretized in small sub-elements. When the integration over the section to determine the internal forces is replaced by the addition over discrete values, the equilibrium conditions for the normal stresses σ_x can be described as follows.

$$\begin{aligned} \sum(\sigma_{x,r} \cdot A_r) - \alpha \cdot N &= 0 \\ \sum(\sigma_{x,r} \cdot A_r \cdot e_{v,r}) - \alpha \cdot M_u &= 0 \\ \sum(\sigma_{x,r} \cdot A_r \cdot e_{u,r}) + \alpha \cdot M_v &= 0 \\ \sum(\sigma_{x,r} \cdot A_r \cdot \omega_r) + \alpha \cdot M_\omega &= 0 \end{aligned}$$

Equation 7.68

where $\sigma_{x,r}$	Normal stress in sub-element r
A_r	Area of sub-element r
$e_{v,r} / e_{u,r}$	Centroid coordinate of sub-element r related to the principal axes
ω_r	Warping constant of the sub-element about shear center M
α	Enlargement factor as variable for optimization
$N / M_u / M_v / M_\omega$	Internal forces as specified in table 1.7 <i>Forces and moments</i>

The shear stresses are imported from the previous elastic design (cf chapter 7.4, page 110). Thus, the shear stresses τ in the centroids of the sub-elements represent input parameters of the linear optimization, whereas the enlargement factor α and the normal stresses $\sigma_{x,r}$ in the centroids of the sub-elements are explicit variables for the optimization.

The further conditions of the optimization task can be set for each sub-element. They are dependent on the yield criteria and take into account the assumed linearization of the yield criteria (cf Figure 7.14). According to the yield criteria of VON MISES, the following interaction formulae are applied.

$$\begin{aligned} \sigma_{x,r} + \alpha \cdot |\tau_r| \cdot (\sqrt{2} - 1) \cdot \sqrt{3} &\leq f_{y,d} \\ -\sigma_{x,r} + \alpha \cdot |\tau_r| \cdot (\sqrt{2} - 1) \cdot \sqrt{3} &\leq f_{y,d} \\ \sigma_{x,r} \cdot (\sqrt{2} - 1) + \alpha \cdot |\tau_r| \cdot \sqrt{3} &\leq f_{y,d} \\ -\sigma_{x,r} \cdot (\sqrt{2} - 1) + \alpha \cdot |\tau_r| \cdot \sqrt{3} &\leq f_{y,d} \end{aligned}$$

Equation 7.69

According to the yield criteria of TRESCA, the interaction formulae are as follows.

$$\begin{aligned}\sigma_{x,r} + \alpha \cdot |\tau_r| \cdot (\sqrt{2} - 1) \cdot 2 &\leq f_{y,d} \\ -\sigma_{x,r} + \alpha \cdot |\tau_r| \cdot (\sqrt{2} - 1) \cdot 2 &\leq f_{y,d} \\ \sigma_{x,r} \cdot (\sqrt{2} - 1) + \alpha \cdot |\tau_r| \cdot 2 &\leq f_{y,d} \\ -\sigma_{x,r} \cdot (\sqrt{2} - 1) + \alpha \cdot |\tau_r| \cdot 2 &\leq f_{y,d}\end{aligned}$$

Equation 7.70

where	$\sigma_{x,r}$	Normal stress in sub-element r
	τ_r	Shear stress in sub-element r
	α	Enlargement factor as variable for optimization
	$f_{y,d}$	Design value of yield stress (cf chapter 5.2, page 69)

Thus, Equation 7.68 and Equation 7.69 resp. Equation 7.70 represent the linear auxiliary conditions for a linear optimization process with the following target function.

$$T(\alpha) = \alpha = \text{Maximum}$$

Equation 7.71

As a result of the linear optimization, the factor α (which determines the plastic capacity of the section as the product of $\alpha \cdot F$) and the plastic stresses in every sub-element r are determined.

The plastic normal stress $\sigma_{x,pl,r}$ represents precisely the normal stress $\sigma_{x,r}$ that turns out as the explicit optimization variable for the sub-element r.

$$\sigma_{x,pl,r} = \sigma_{x,r}$$

Equation 7.72

The plastic shear stress $\tau_{pl,r}$ is the product of the enlargement factor α and the elastic shear stress τ_r (i.e. the result of the previous elastic design) in the centroid of the sub-element r.

$$\tau_{pl,r} = \alpha \cdot \tau_r$$

Equation 7.73

The plastic equivalent stress $\sigma_{eqv,pl,r}$ is dependent on the selected yield criteria. According to the theory of VON MISES, it is determined for the sub-element r as follows.

$$\sigma_{v,pl,r} = \max \begin{pmatrix} |\sigma_{x,r} + \alpha \cdot |\tau_r| \cdot (\sqrt{2} - 1) \cdot \sqrt{3}|, \\ |-\sigma_{x,r} + \alpha \cdot |\tau_r| \cdot (\sqrt{2} - 1) \cdot \sqrt{3}|, \\ |\sigma_{x,r} \cdot (\sqrt{2} - 1) + \alpha \cdot |\tau_r| \cdot \sqrt{3}|, \\ |-\sigma_{x,r} \cdot (\sqrt{2} - 1) + \alpha \cdot |\tau_r| \cdot \sqrt{3}| \end{pmatrix}$$

Equation 7.74

According to the yield criteria of TRESCA, the following investigation is applied.

$$\sigma_{v,pl,r} = \max \begin{pmatrix} |\sigma_{x,r} + \alpha \cdot |\tau_r| \cdot (\sqrt{2} - 1) \cdot 2|_r \\ |-\sigma_{x,r} + \alpha \cdot |\tau_r| \cdot (\sqrt{2} - 1) \cdot 2|_r \\ |\sigma_{x,r} \cdot (\sqrt{2} - 1) + \alpha \cdot |\tau_r| \cdot 2|_r \\ |-\sigma_{x,r} \cdot (\sqrt{2} - 1) + \alpha \cdot |\tau_r| \cdot 2|_r \end{pmatrix}$$

Equation 7.75

Unutilized Reserve

In the last column, the percentaged share of those sectional parts is shown that do not plastify completely, i.e. the Simplex elements in which the yield stress is not reached for the combined loading condition in question.

7.7 Check of c/t Zones

If the comparison with the limiting c/t zones according to DIN 18800 has been enabled in the *General Data* dialog box, the table 5.1 *Check of c/t zones* is presented after the analysis. The results are listed for every *Location x* as defined in table 1.7 *Forces and moments* (cf chapter 5.7, page 84).

The *Governing* values of all load cases and locations x can be read at the end of the list.

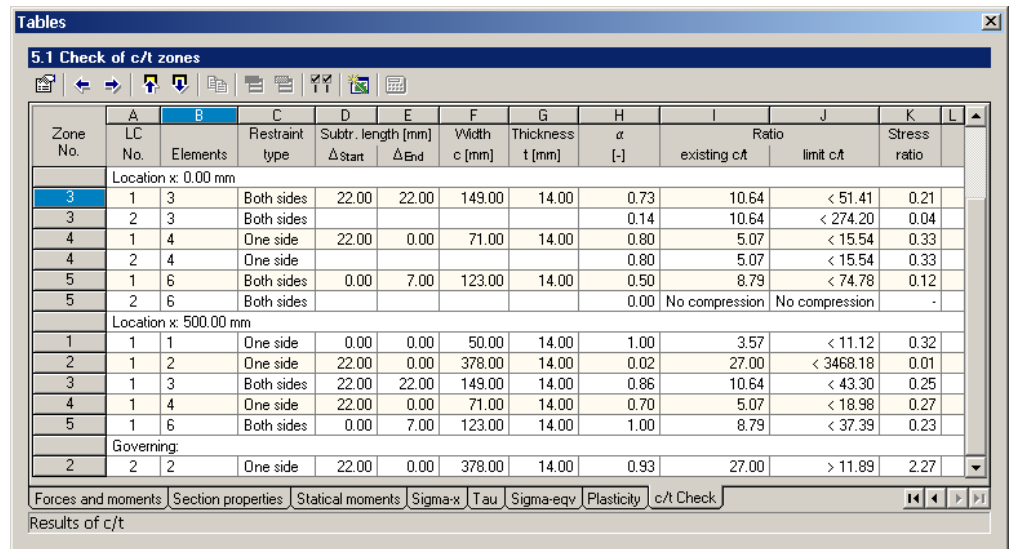

Zone No.	A LC No.	B Elements	C Restraint type	D Subtr. length [mm] Δ _{start}	E Δ _{End}	F Width c [mm]	G Thickness t [mm]	H α [-]	I Ratio existing c/t	J Ratio limit c/t	K Stress ratio	L
Location x: 0.00 mm												
3	1	3	Both sides	22.00	22.00	149.00	14.00	0.73	10.64	< 51.41	0.21	
3	2	3	Both sides					0.14	10.64	< 274.20	0.04	
4	1	4	One side	22.00	0.00	71.00	14.00	0.80	5.07	< 15.54	0.33	
4	2	4	One side					0.80	5.07	< 15.54	0.33	
5	1	6	Both sides	0.00	7.00	123.00	14.00	0.50	8.79	< 74.78	0.12	
5	2	6	Both sides					0.00	No compression	No compression	-	
Location x: 500.00 mm												
1	1	1	One side	0.00	0.00	50.00	14.00	1.00	3.57	< 11.12	0.32	
2	1	2	One side	22.00	0.00	378.00	14.00	0.02	27.00	< 3468.18	0.01	
3	1	3	Both sides	22.00	22.00	149.00	14.00	0.86	10.64	< 43.30	0.25	
4	1	4	One side	22.00	0.00	71.00	14.00	0.70	5.07	< 18.98	0.27	
5	1	6	Both sides	0.00	7.00	123.00	14.00	1.00	8.79	< 37.39	0.23	
Governing:												
2	2	2	One side	22.00	0.00	378.00	14.00	0.93	27.00	> 11.89	2.27	

Figure 7.15: Table 5.1 *Check of c/t zones*

Zone Number

For every location x, the c/t ratios are listed by numbers of the c/t zones. The zones are made up of elements connected in a definable 'straight' line. In the *General data* dialog box, the settings when to create end restraints of the c/t zones can be controlled (cf Figure 4.43, page 60).

LC Number

In this column, the number of the respective load case is shown.

Elements

This column lists all elements that belong to each c/t zone.

Restraint Type

This column gives information on the restraints of each c/t zone as per definition in table 1.6 *c/t Zones* (cf chapter 5.6, page 82). They can be supported on one side only (outstand flange) or on both sides (internal compression part).

Subtracted Length Δ_{Start} / Δ_{End}

In these two columns, the distances of the restraint from the start resp. end nodes of the relevant elements are listed. Those values correspond to the lengths as defined in columns E and F of table 1.6 *c/t Zones* (cf chapter 5.6, page 82).

Width c

The total width of a c/t zone is made up of the lengths of all contained elements which is reduced by the subtracted lengths at the start and end of this zone.

Thickness t

The thickness is defined as the smallest thickness of all elements which are integral parts of the c/t zone.

Existing c/t

In this column, the resulting width-to-thickness ratios are listed. If the c/t zone is subject to tensile stresses, the remark *No compression* is indicated instead.

Limiting c/t

This column gives information on the limiting value of the c/t ratio which depends on the selected design method (cf chapter 4.4.2.4, page 60). The limiting values are determined according to the following tables of DIN 18800 Part 1.

- Elastic-Elastic: Tables 12, 13 and 14
- Elastic-Plastic: Table 15
- Plastic-Plastic: Table 18

Ratio

By dividing the values of the existing c/t ratio by the limiting c/t ratio, the overall utilization ratio of every c/t zone is determined.

$$\sigma_{x,Start} / \sigma_{x,End}$$

These two columns are only presented for the Elastic-Elastic design method. They give information on the elastic normal stresses at the start resp. end nodes of each c/t zone.

$$\psi$$

This column contains the ratio of the values from the two previous columns. If there are tensile stresses at both ends, no values of the stress ratio are determined.

$$k_{\sigma}$$

As before, this column is only presented for the Elastic-Elastic design method. It includes the auxiliary values for further analyses that are based on the ratio ψ of each c/t zone with compressive stresses.

$$\tau$$

This column is only available for the Elastic-Elastic design method with consideration of the shear stresses according to the BEUTH comment. It gives information on the maximum shear stresses of each c/t zone.

$$Q_{u,m} / Q_{v,m}$$

These columns are also only available for the Elastic-Elastic design method with consideration of the shear stresses according to the BEUTH comment. They contain the mean statical moments (absolute values) related the principal axes u and v of each c/t zone.

$$\alpha$$

This column is only presented if the Elastic-Plastic or Plastic-Plastic design method has been chosen (cf chapter 4.4.2.4, page 60). It gives information on the compression zone factor of each c/t zone, i.e. the ratio of compressive width to total width.

7.8 Shear Wall Section Properties

This results table lists the sectional characteristics for the constituent components of a shear wall section.

Sh. Wall No.	Shear center M		Moments of inertia			Torsional constants		Warping constant	Contained elements
	Y _{M,0} [m]	Z _{M,0} [m]	I _y [m ⁴]	I _z [m ⁴]	I _{yz} [m ⁴]	J St.Ven. [m ⁴]	J Bredt [m ⁴]	I _ω [m ⁶]	
1	-2.733	10.663	103.462	60.571	21.499	0.247	0.000	816.912	3,6,34-36,46
2	0.000	0.000	0.445	5.893	-0.874	0.060	0.000	0.000	4,15
3	27.890	18.050	9.769	0.186	0.627	0.067	0.000	0.000	16,19
4	37.200	15.592	26.661	22.250	-2.685	0.183	0.000	55.428	18,21,23,39,45,47
5	7.660	0.000	18.073	0.193	0.808	0.082	0.000	0.000	25,33
6	31.775	6.150	0.013	12.409	0.000	0.068	0.000	0.000	41,43,44
			158.422	101.502	19.374	0.707	0.000	872.341	

Figure 7.16: Table 6.1 Shear wall section properties

Before the analysis, SHAPE checks whether all elements of the section are rigidly connected to each other and thus constitute an interconnecting cross-section. If this is not the case, a warning appears (cf Figure 6.3, page 91) and asks whether the calculation should be done according to the theory of stiffening shear walls. According to this approach, the individual shear walls (braced panels) are assumed as shear-flexible which are tied to each other via floors or beams. The sectional properties and stresses are calculated in a different manner than for coherent sections.

The analytical approach of shear wall systems can also be applied for sectional parts that feature different materials and are combined without the facility to transfer shear forces. The design of those shear-flexible composite sections results in the ideal section properties with the proportionate stresses.

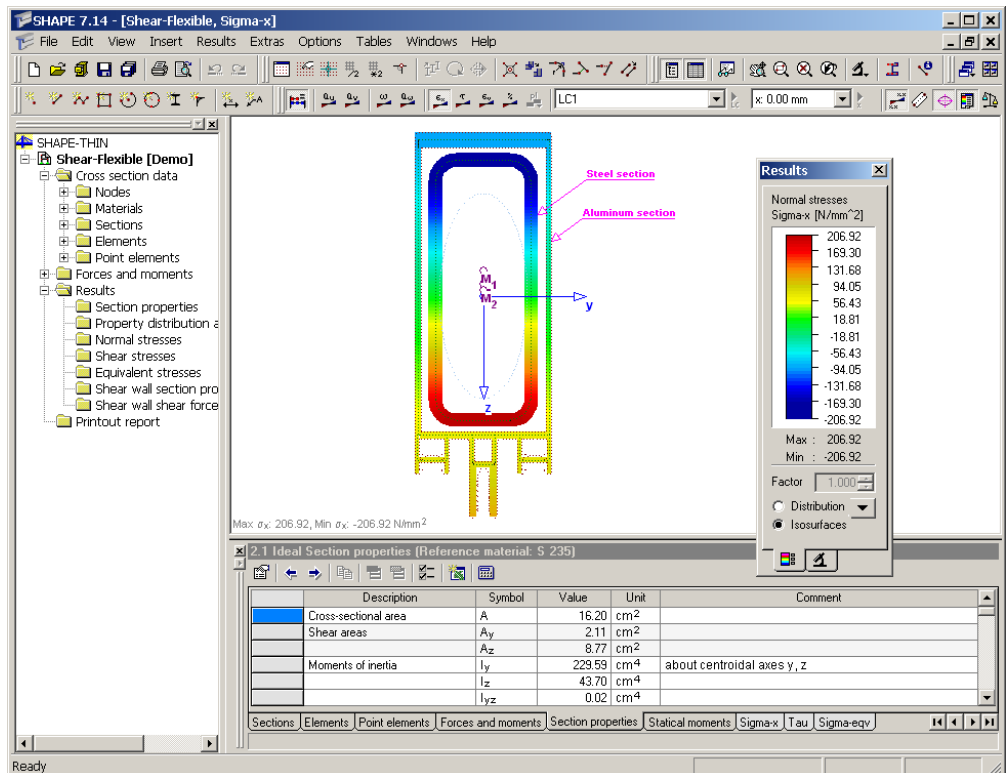

Figure 7.17: Ideal section properties and normal stresses of shear-flexible composite section

If the non-coherent section consists of elements with different materials, the header of table 2.1 reads "*Ideal Section Properties*" inclusive of the reference material which has been defined in the *Details* tab of the *General Data* dialog box (cf chapter 4.4.2.2, page 56).

Shear Wall Number

A shear wall can be comprised of a single element or of several interconnected elements. Each shear wall is assigned a number whose *Constituent Elements* are shown in the final column.

Shear Center $y_{M,0}$ / $z_{M,0}$

In these two columns, the shear center coordinates of each shear wall are listed which are related to the global origin (0/0). In the graphics, the individual shear centers are labeled as M_1, M_2 etc.

Moments of Inertia I_y / I_z / I_{yz}

The 2nd moments of area and the centrifugal moment are presented individually for each shear wall of the non-connecting section. The moments of inertia refer to the section-related axis system y,z which lies parallel to the global system y_0,z_0 through the centroid C. This table does not provide any principal 2nd moments of area for each shear wall section.



Please note that the sum of the moments of inertia is determined **without** the parallel axis theorem component $A_i \cdot e_i^2$.

Torsional Constants $J_{St.Venant}$ / J_{Bredt}

In these two columns, the torsional constants due to ST. VENANT (open sectional parts) and BREDT (closed cells) are listed for each shear wall. The last line presents the sums of all individual values.

Warping Constant I_ω

For each shear wall, the warping constant is displayed which is related to the shear center M_i of every individual shear wall.

Contained Elements

In the last column, all elements are listed that set up the respective shear wall.

7.9 Shear Forces

The shear forces that are listed in this table are related to the individual parts of the non-coherent section. They are used to determine the shear stresses due to the internal forces of every *Location x* that has been defined in table 1.7 *Forces and moments*.

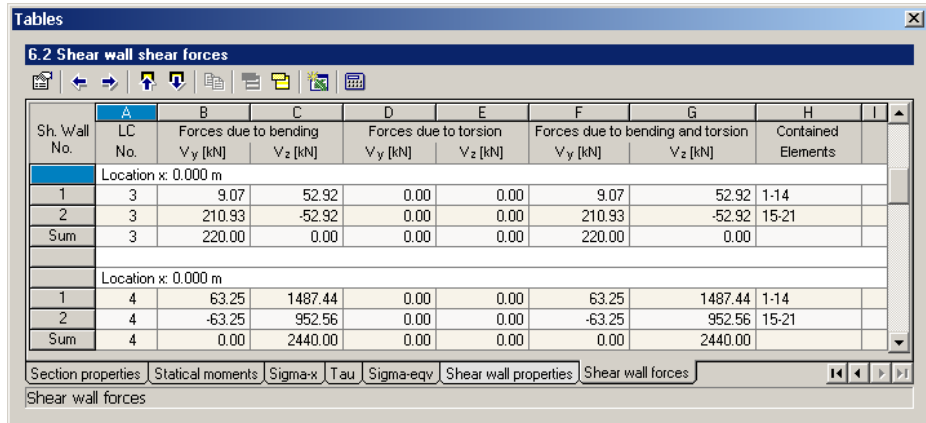

Sh. Wall No.	LC No.	Forces due to bending V_y [kN] V_z [kN]		Forces due to torsion V_y [kN] V_z [kN]		Forces due to bending and torsion V_y [kN] V_z [kN]		Contained Elements
Location x: 0.000 m								
1	3	9.07	52.92	0.00	0.00	9.07	52.92	1-14
2	3	210.93	-52.92	0.00	0.00	210.93	-52.92	15-21
Sum	3	220.00	0.00	0.00	0.00	220.00	0.00	
Location x: 0.000 m								
1	4	63.25	1487.44	0.00	0.00	63.25	1487.44	1-14
2	4	-63.25	952.56	0.00	0.00	-63.25	952.56	15-21
Sum	4	0.00	2440.00	0.00	0.00	0.00	2440.00	

Figure 7.18: Table 6.2 *Shear wall shear forces*

Shear Wall Number

The shear forces of the following columns are listed by the shear wall numbers of table 6.1 *Shear wall section properties*. The *Contained Elements* of each shear wall are shown in the final column.

Load Case Number

In this column, the number of the respective load case is shown.

Forces due to Bending V_y / V_z

The force of every shear wall *i* due to the shear force that acts in direction of the centroidal axis *y* or *z* is determined as follows.

$$V_{y,i} = \frac{V_y \cdot (I_{z,i} \cdot I_y - I_{yz,i} \cdot I_{yz}) - V_z \cdot (I_{z,i} \cdot I_{yz} - I_{yz,i} \cdot I_z)}{I_y \cdot I_z - I_{yz}^2}$$

$$V_{z,i} = \frac{V_y \cdot (I_{yz,i} \cdot I_y - I_{y,i} \cdot I_{yz}) - V_z \cdot (I_{yz,i} \cdot I_{yz} - I_{y,i} \cdot I_z)}{I_y \cdot I_z - I_{yz}^2}$$

Equation 7.76

- where V_y / V_z Shear forces in direction of global centroidal axes *y* or *z* (transformed if entered in directions of principal axes *u* or *v*) acting on total section
- $V_{y,i} / V_{z,i}$ Shear forces of shear wall *i* in directions *y* or *z*
- $I_{y,i} / I_{z,i} / I_{yz,i}$ 2nd moments of area of shear wall *i*, related to global axes in centroid of shear wall *C_i*
- I_y / I_z 2nd moments of area about axes *y* or *z*, related to total center of gravity *C*

This table does not provide any forces that are related to the principal axes *u* and *v*.

Forces due to Torsion V_y / V_z

In these two columns, the torsional constants due to ST. VENANT (open sectional parts) and BREDT (closed cells) are listed for each shear wall. The last line presents the sums of all individual values.

$$V_{y,i} = \frac{M_{xs} \cdot [I_{yz,i} \cdot (y_{M,i} - y_M) - I_{z,i} \cdot (z_{M,i} - z_M)]}{\sum_{i=1}^n [I_{\omega,i} + I_{y,i} \cdot (y_{M,i} - y_M)^2 - 2 \cdot I_{yz,i} \cdot (y_{M,i} - y_M) \cdot (z_{M,i} - z_M) + I_{z,i} \cdot (z_{M,i} - z_M)^2]}$$

$$V_{z,i} = \frac{M_{xs} \cdot [I_{y,i} \cdot (y_{M,i} - y_M) - I_{yz,i} \cdot (z_{M,i} - z_M)]}{\sum_{i=1}^n [I_{\omega,i} + I_{y,i} \cdot (y_{M,i} - y_M)^2 - 2 \cdot I_{yz,i} \cdot (y_{M,i} - y_M) \cdot (z_{M,i} - z_M) + I_{z,i} \cdot (z_{M,i} - z_M)^2]}$$

Equation 7.77

where M_{xs}	Total secondary torsional moment
$V_{y,i}$ resp. $V_{z,i}$	Shear force of shear wall i in direction y resp. z
$I_{y,i} / I_{z,i} / I_{yz,i}$	2 nd moments of area of shear wall i related to the global axes in centroid C_i of shear wall i
$I_{\omega,i}$	Warping constant of shear wall i related to shear center M_i of shear wall i
$y_{M,i}$ resp. $z_{M,i}$	Global coordinate of shear center M_i of shear wall i
y_M resp. z_M	Global coordinate of overall shear center M
n	Number of shear walls in overall section



Usually, there are large distances between the individual shear wall components. Thus, the warping torsion assumes the much larger portion of the total torsional moment. Although the forces due to the primary torsional moment are calculated internally, they are not listed in this table. Strictly speaking, those results are rather torsional moments than forces. This means that the primary torsional moment accordingly causes the primary torsional moment $M_{xp,i}$ in each section wall i (split into the ST. VENANT and BREDT components) and, therefore, no shear forces $V_{y,i}$ resp. $V_{z,i}$.

Composite Sections

If the elements of the section feature different materials, the 2nd moments of area and the warping constant are replaced by the products of the 2nd moments of area resp. warping constant and the respective elastic moduli (Equation 7.76 and Equation 7.77).

Forces due to Bending and Torsion V_y / V_z

In these two columns, the sums of the shear forces due to bending and torsion are shown. They are provided for each shear wall component in the respective y and z directions.

Contained Elements

In the last column, all elements are listed that set up the respective shear wall.



Shear Stress Design of Shear Walls

The shear forces $V_{y,i}$ and $V_{z,i}$ are related to the shear center M_i of every individual shear wall component i . With those shear forces, the shear stresses τ are determined for every shear wall as follows.

$$\tau_{V_{y,i}} = -\frac{V_{y,i} \cdot Q_{z,i}}{I_{z,i} \cdot t^*} \qquad \tau_{V_{z,i}} = -\frac{V_{z,i} \cdot Q_{y,i}}{I_{y,i} \cdot t^*}$$

Equation 7.78

where	$V_{y,i} / V_{z,i}$	Shear force of shear wall i in direction y resp. z
	$Q_{z,i} / Q_{y,i}$	1 st moments of area of shear wall i related to the global axes in centroid C_i of shear wall i
	$I_{y,i} / I_{z,i}$	2 nd moments of area of shear wall i related to the global axes in centroid C_i of shear wall i
	t^*	Effective element thickness for shear transfer

As for the primary torsional moment M_{xp} , the ST. VENANT and BREDT components are allocated to each shear wall according to the torsional stiffnesses.

$$M_{xp,St.Venant,i} = M_{xp} \cdot \frac{J_{St.Venant,i}}{J} \qquad M_{xp,Bredt,i} = M_{xp} \cdot \frac{J_{Bredt,i}}{J}$$

Equation 7.79

The shear stresses τ can then be determined for each shear wall i and for the entire section.

$$\tau_{M_{xp,St.Venant,i}} = \frac{M_{xp,St.Venant,i}}{J_{St.Venant,i}} \cdot t^* \qquad \tau_{M_{xp,Bredt,i}} = \frac{M_{xp,Bredt,i}}{J} \cdot t^*$$

Equation 7.80

where	$M_{xp,St.Venant,i}$	St. Venant torsional moment of shear wall i
	$J_{St.Venant,i}$	St. Venant torsional constant of shear wall i
	t^*	Effective element thickness for shear transfer
	M_{xp}	St. Venant torsional moment of overall shear wall section
	J	St. Venant torsional constant of overall section (i.e. sum of St. Venant and Bredt components of all shear walls)

Concerning closed sectional parts with cells of a shear wall, the torsional shear stresses due to Bredt's theory are calculated as follows.

$$\tau_{M_{xp,Bredt,i}} = \frac{M_{xp,Bredt,i}}{2 \cdot A_{m,i} \cdot t^*}$$

Equation 7.81

where	$M_{xp,Bredt,i}$	Bredt component of the primary torsional moment of shear wall i
	$A_{m,i}$	Cell area bounded by center lines of shear wall i
	t^*	Effective element thickness for shear transfer

7.10 Classification

LC1 - Design Load

x: 0.00 cm

The results table 5.1 *Classification of the Cross-Section* is displayed if the calculation of the effective cross-sections has been carried out according to the EN 1993-1 standard. In this table, the results of the current *Load Case* at the selected *Location x* are shown, i.e. the load case and location which are set in the menu bar. Those can be changed via the lists or the buttons [►] in the toolbar as seen to left.

If the effective cross-section properties have been analyzed according to DIN 18800, the results table 5.1 *Check of c/t zones* is displayed instead of the *Classification* table. This table is described in chapter 7.7 on page 120.

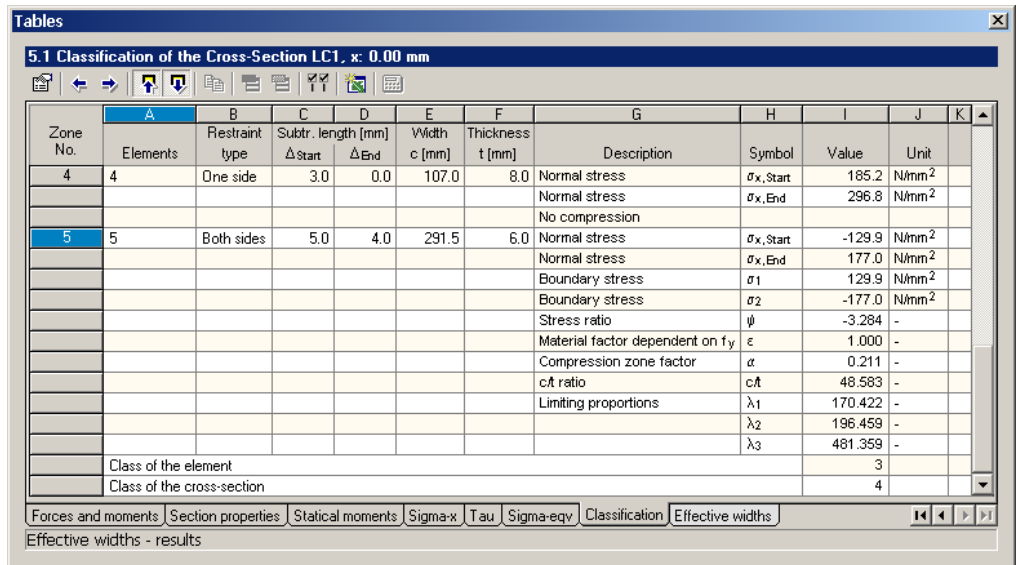

Zone No.	A		B		C		D		E		F		G		H		I		J		K										
	Elements	Restraint type	Subtr. length [mm]	Width c [mm]	Thickness t [mm]	Δ _{Start}	Δ _{End}	Width c [mm]	Thickness t [mm]	Description	Symbol	Value	Unit																		
4	4	One side	3.0	0.0	107.0				8.0	Normal stress	σ _{x,Start}	185.2	N/mm ²																		
										Normal stress	σ _{x,End}	296.8	N/mm ²																		
										No compression																					
5	5	Both sides	5.0	4.0	291.5				6.0	Normal stress	σ _{x,Start}	-129.9	N/mm ²																		
										Normal stress	σ _{x,End}	177.0	N/mm ²																		
										Boundary stress	σ ₁	129.9	N/mm ²																		
										Boundary stress	σ ₂	-177.0	N/mm ²																		
										Stress ratio	ψ	-3.284	-																		
										Material factor dependent on f _y	ε	1.000	-																		
										Compression zone factor	α	0.211	-																		
										c/t ratio	c/t	48.583	-																		
										Limiting proportions	λ ₁	170.422	-																		
											λ ₂	196.459	-																		
		λ ₃	481.359	-																											
		Class of the element																				3									
		Class of the cross-section																				4									

Figure 7.19: Table 5.1 *Classification of the Cross-Section*

Zone No.

The results are listed by zone numbers, i.e. elements connected in a definable 'straight' line. In the *General data* dialog box, the settings when to create end restraints of the c/t zones can be controlled (cf Figure 4.44, page 61).

Elements

All elements that belong to the c/t zone are listed in this input field of the dialog box or table.

Restraint Type

This column gives information on the restraints of each c/t zone as per definition in table 1.6 *c/t Zones* (cf chapter 5.6, page 82). They can be supported on one side only (outstand flange) or on both sides (internal compression part).

Subtracted Length Δ_{Start} / Δ_{End}

In these two columns, the distances of the restraint from the start resp. end nodes of the relevant elements are listed. Those values correspond to the lengths as defined in columns E and F of table 1.6 *c/t Zones* (cf chapter 5.6, page 82).

Width c

The total width of a c/t zone is made up of the lengths of all contained elements which is reduced by the subtracted lengths at the start and end of this zone (e.g. fillets).

Thickness t

The thickness is defined as the smallest thickness of all elements which are integral parts of the c/t zone.

Description

In this column, the various parameters are listed that are essential to classify the cross-section.

Normal Stresses $\sigma_{x,Start} / \sigma_{x,End}$

These two lines give information on the normal stresses at the start resp. end nodes of each c/t zone. Please note that those are the stresses of the original cross-section. Tensile stresses are positive, compressive stresses negative (i.e. inverse to the definition in EN 1993-1-1).

Boundary Stresses σ_1 / σ_2

These stresses are determined from the normal stresses. σ_1 is the maximum value of stress at either the start node or the end node of the c/t zone. Accordingly, σ_2 represents the minimum value of both stresses.

Stress Ratio ψ

This line contains the ratio of the values from the two previous lines. If there are tensile stresses at both ends, no values of the stress ratio are determined.

Material Factor ε Dependent on f_y

According to Table 5.2 in EN 1993-1-1, the material factor is determined as follows:

$$\varepsilon = \sqrt{\frac{235}{f_y}}$$

Equation 7.82

Compression Zone Factor α

The compression zone factor describes the ratio of compressive width to total width of each c/t zone.

c/t Zone Values c/t

In this line, the resulting width-to-thickness ratios are listed. If the c/t zone is subject to tensile stresses, the remark *No compression* is shown instead.

Limiting Proportions $\lambda_1 / \lambda_2 / \lambda_3$

The limiting proportions of each c/t zone depend on the restraint type (internal compression part or outstand flange) and on the stress distribution (bending or/and compression). In the respective equations of Table 5.2 in EN 1993-1-1, the parameters ε , α and ψ are considered accordingly.

λ_1 represents the limit value for Class 1 cross-sections, λ_2 the limit value for Class 2 cross-sections and λ_3 the limit value for Class 3 cross-sections.

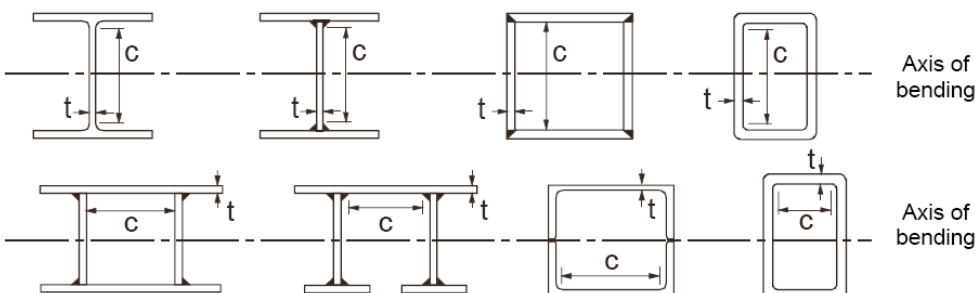
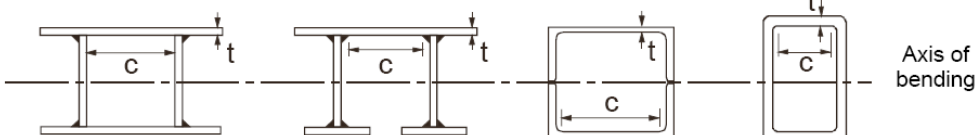
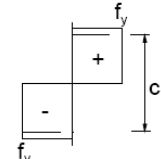
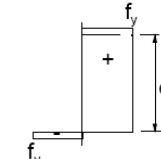
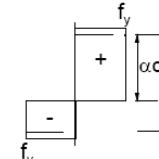
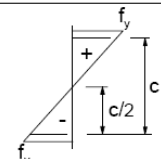
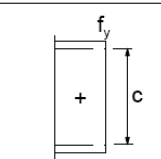
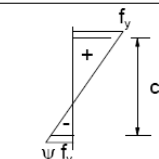
Internal compression parts						
				Axis of bending		
				Axis of bending		
Class	Part subject to bending	Part subject to compression	Part subject to bending and compression			
Stress distribution in parts (compression positive)						
1	$c/t \leq 72\varepsilon$	$c/t \leq 33\varepsilon$	when $\alpha > 0,5$: $c/t \leq \frac{396\varepsilon}{13\alpha - 1}$ when $\alpha \leq 0,5$: $c/t \leq \frac{36\varepsilon}{\alpha}$			
2	$c/t \leq 83\varepsilon$	$c/t \leq 38\varepsilon$	when $\alpha > 0,5$: $c/t \leq \frac{456\varepsilon}{13\alpha - 1}$ when $\alpha \leq 0,5$: $c/t \leq \frac{41,5\varepsilon}{\alpha}$			
Stress distribution in parts (compression positive)						
3	$c/t \leq 124\varepsilon$	$c/t \leq 42\varepsilon$	when $\psi > -1$: $c/t \leq \frac{42\varepsilon}{0,67 + 0,33\psi}$ when $\psi \leq -1^*)$: $c/t \leq 62\varepsilon(1 - \psi)\sqrt{-\psi}$			
$\varepsilon = \sqrt{235/f_y}$	f_y	235	275	355	420	460
	ε	1,00	0,92	0,81	0,75	0,71

*) $\psi \leq -1$ applies where either the compression stress $\sigma \leq f_y$ or the tensile strain $\varepsilon_y > f_y/E$





Outstand flanges						
		Rolled sections		Welded sections		
Class	Part subject to compression	Part subject to bending and compression				
		Tip in compression		Tip in tension		
Stress distribution in parts (compression positive)						
1	$c/t \leq 9\epsilon$	$c/t \leq \frac{9\epsilon}{\alpha}$	$c/t \leq \frac{9\epsilon}{\alpha\sqrt{\alpha}}$	$c/t \leq \frac{9\epsilon}{\alpha\sqrt{\alpha}}$	$c/t \leq \frac{9\epsilon}{\alpha\sqrt{\alpha}}$	$c/t \leq \frac{9\epsilon}{\alpha\sqrt{\alpha}}$
2	$c/t \leq 10\epsilon$	$c/t \leq \frac{10\epsilon}{\alpha}$	$c/t \leq \frac{10\epsilon}{\alpha\sqrt{\alpha}}$	$c/t \leq \frac{10\epsilon}{\alpha\sqrt{\alpha}}$	$c/t \leq \frac{10\epsilon}{\alpha\sqrt{\alpha}}$	$c/t \leq \frac{10\epsilon}{\alpha\sqrt{\alpha}}$
Stress distribution in parts (compression positive)						
3	$c/t \leq 14\epsilon$	$c/t \leq 21\epsilon\sqrt{k_\sigma}$ For k_σ see EN 1993-1-5				
$\epsilon = \sqrt{235/f_y}$	f_y	235	275	355	420	460
	ϵ	1,00	0,92	0,81	0,75	0,71

Figure 7.20: Table 5.2 in EN 1993-1-1

Symbol

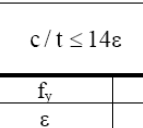
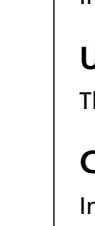
This column lists the symbols that are associated with the previous descriptions of the parameters.

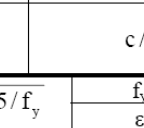
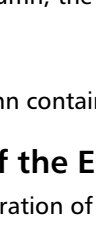
Value

In this column, the values of the various parameters are listed.

Unit

This column contains the units of all relevant values.

Class of the Element

In consideration of the limiting proportions λ , the elements of each zone are allocated to Class 1, 2, 3 or 4.

Class of the Cross-Section

According to EN 1993-1-1, 5.5.2 (6), the cross-section is classified in accordance with the least favorable class of its compression parts.

7.11 Effective Widths

During the analysis, a new effective cross-section is created from the initial cross-section. This is carried out separately for every location x of every load case. New nodes and elements are created for every effective cross-section. Those are numbered independently of the node or element numbering of the original section. The new elements lie either entirely or only partially on the center lines of the original elements.

After the analysis the cross-section properties, the statical moments, warping ordinates and stresses are listed in the respective results tables with reference to the current effective cross-section, i.e. location x of the active load case. Creating the effective cross-section, however, does not affect the input tables 1.1 to 1.7. They contain only the data that are related to original cross-section.

The analysis of the effective cross-section takes no notice of section properties that would not make sense on the basis of this model, e.g. the "effective" cross-section weight or perimeter. In the same way, no plastic cross-section properties are determined when analyzing the effective cross-sections.

You can activate the *Load Case* or *Location x* whose results are to be displayed via the two lists in the toolbar or by using the buttons [▶].

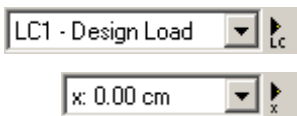

The layout of this results table depends on the standard which has been selected in the *General Data* dialog box (cf Figure 4.44, page 61).

Via the button [Show columns], the various table items can be selected in a specific dialog box.



7.11.1 DIN 18800

The analysis of the effective cross-section properties according to DIN 18800 also implies to check the c/t ratios. Thus, it is recommended to consider the previous table 5.1 *Check of c/t zones* as well. This table is described in chapter 7.7 on page 120.

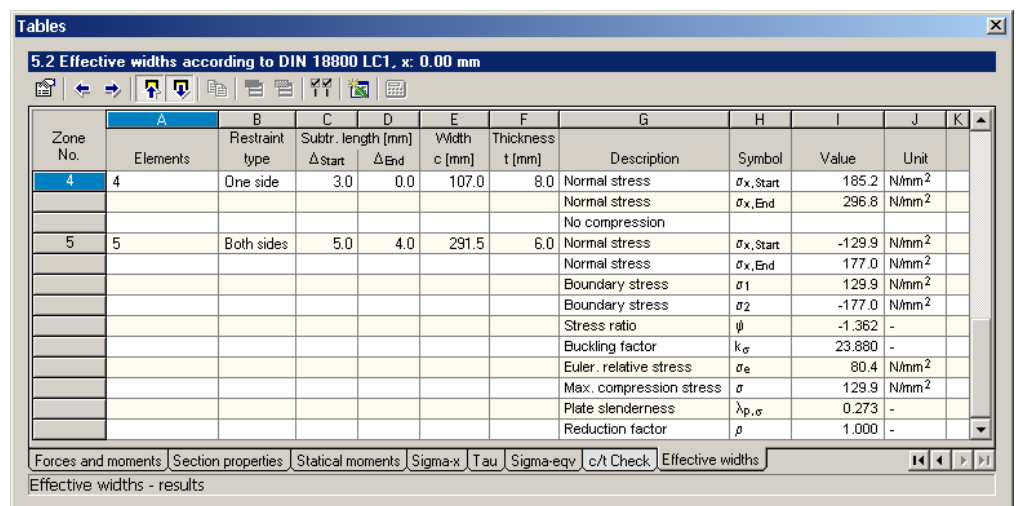

Zone No.	A Elements	B Restraint type	C Subtr. length [mm]		E Width c [mm]	F Thickness t [mm]	G			
			Δ_{start}	Δ_{end}			Description	Symbol	Value	Unit
4	4	One side	3.0	0.0	107.0	8.0	Normal stress	$\sigma_{x, start}$	185.2	N/mm ²
							Normal stress	$\sigma_{x, end}$	296.8	N/mm ²
							No compression			
5	5	Both sides	5.0	4.0	291.5	6.0	Normal stress	$\sigma_{x, start}$	-129.9	N/mm ²
							Normal stress	$\sigma_{x, end}$	177.0	N/mm ²
							Boundary stress	σ_1	129.9	N/mm ²
							Boundary stress	σ_2	-177.0	N/mm ²
							Stress ratio	ψ	-1.362	-
							Buckling factor	k_σ	23.880	-
							Euler. relative stress	σ_e	80.4	N/mm ²
							Max. compression stress	σ	129.9	N/mm ²
							Plate slenderness	$\lambda_{p, \sigma}$	0.273	-
Reduction factor	ρ	1.000	-							

Figure 7.21: Table 5.2 *Effective Widths according to DIN 18800*

Zone No.

The results are listed by zone numbers, i.e. elements connected in a definable 'straight' line. In the *General data* dialog box, the settings when to create end restraints of the c/t zones can be controlled (cf Figure 4.44, page 61).

Elements

All elements that belong to the c/t zone are listed in this input field.

Restraint Type

This column gives information on the restraints of each c/t zone as per definition in table 1.6 *c/t Zones* (cf chapter 5.6, page 82). They can be supported on one side only (outstand flange) or on both sides (internal compression part).

Subtracted Length $\Delta_{\text{Start}} / \Delta_{\text{End}}$

In these two columns, the distances of the restraint from the start resp. end nodes of the relevant elements are listed. Those values correspond to the lengths as defined in columns E and F of table 1.6 *c/t Zones* (cf chapter 5.6, page 82).

Width c

The total width of a c/t zone is made up of the lengths of all contained elements which is reduced by the subtracted lengths at the start and end of this zone.

Thickness t

The thickness is defined as the smallest thickness of all elements which are integral parts of the c/t zone.

Description

In this column, the various parameters are listed that are essential to determine the effective widths. If the c/t zone is subject to tensile stresses, the remark *No compression* is indicated instead.

Normal Stresses $\sigma_{x,\text{Start}} / \sigma_{x,\text{End}}$

These two lines give information on the normal stresses at the start resp. end nodes of each c/t zone. Please note that those are the stresses of the gross cross-section. Tensile stresses are positive, compressive stresses negative.

Boundary Stresses σ_1 / σ_2

These stresses are determined from the normal stresses. σ_1 is the maximum value of stress at either the start node or the end node of the c/t zone. Accordingly, σ_2 represents the minimum value of both stresses. Additionally, the signs are reversed, i.e. compressive stresses are set positive and tensile stresses are set negative.

Stress Ratio ψ

This line contains the ratio of the values from the two previous lines. If there are tensile stresses at both ends, no values of the stress ratio are determined.

Buckling Factor k_σ

The buckling factor is specified in DIN 18800 Part 2, Table 26. To determine k_σ in this table, the restraint type and the stress ratio have to be considered.

Euler Relative Stress σ_e

This value is necessary to determine the plate slenderness. It is calculated according to the following equation:

$$\sigma_e = 189800 \cdot \left(\frac{t}{c}\right)^2 \quad [\text{N/mm}^2]$$

Equation 7.83

Maximum Compressive Stress σ

In this line, the maximum value of the compression stress is specified.

Plate Slenderness $\bar{\lambda}_{p,\sigma}$

The related plate slenderness of the metal sheet for buckling is determined according to the following equation:

$$\bar{\lambda}_{p,\sigma} = \sqrt{\frac{\sigma \cdot \gamma_M}{k_\sigma \cdot \sigma_e}}$$

Equation 7.84

Reduction Factor ρ

Different reduction factors have to be considered for either internal compression parts or outstand flanges.

- **Internal compression elements**

$$\rho = \frac{1}{\bar{\lambda}_{p,\sigma}} \cdot \left(0.97 + 0.03 \cdot \psi - \frac{0.16 + 0.06 \cdot \psi}{\bar{\lambda}_{p,\sigma}} \right)$$

Equation 7.85

- **Outstand compression elements**

$$\rho = \frac{0.7}{\bar{\lambda}_{p,\sigma}}$$

Equation 7.86

Effective Width $c' / c'_1 / c'_2$

The effective widths are determined as follows (cf DIN 18800 Part 2, Table 27).

- **Internal compression elements**

$$\begin{aligned} c' &= c & \text{for } \bar{\lambda}_{p,\sigma} \leq 0.673 \\ c' &= \rho \cdot c & \text{for } \bar{\lambda}_{p,\sigma} > 0.673 \end{aligned}$$

Equation 7.87

The effective width c' is then distributed into its components c'_1 and c'_2 .

$$\begin{aligned} c'_1 &= \rho \cdot c \cdot k_1 & \text{for } k_1 = -0.04 \cdot \psi^2 + 0.12 \cdot \psi + 0.42 \\ c'_2 &= \rho \cdot c \cdot k_2 & \text{for } k_2 = 0.04 \cdot \psi^2 - 0.12 \cdot \psi + 0.58 \end{aligned}$$

Equation 7.88

- **Outstand compression elements**

$$c' = \rho \cdot c \leq c \quad \text{for } \bar{\lambda}_{p,\sigma} > 0.673$$

Equation 7.89

Dependent on the stress distribution, the effective width c' is allocated as follows.

$$\begin{aligned} c' & & \text{for } \psi \geq 0 \\ c' + c_{\text{Tens}} & & \text{for } \psi < 0 \text{ and tensile stresses at unrestrained edge} \\ c' + c_{\text{Tens}} & & \text{for } \psi < 0 \text{ and tensile stresses at restrained edge (} c' \text{ has to be measured from the zero-crossing towards the unrestrained edge)} \end{aligned}$$

where c_{Tens} zone width with tensile stresses

Equation 7.90

Symbol

This column lists the symbols that are associated with the previous descriptions of the parameters.

Value

In this column, the values of the various parameters are listed.

Unit

This column contains the units of all relevant values.

7.11.2 EN 1993-1

The analysis of the effective widths makes only sense for Class 4 cross-sections. In table 5.2 of the EN 1993-1-1 standard, the maximum width-to-thickness ratios for compression parts are specified (cf Figure 7.20, page 130).

The *Class of the Cross-Section* is specified in the last line of this table.

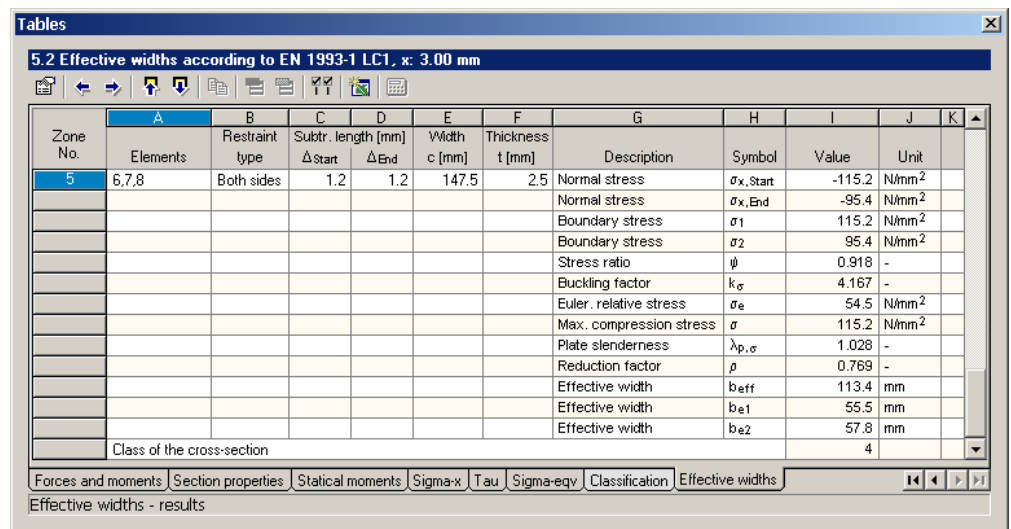

Zone No.	A Elements	B Restraint type	C Subtr. length [mm] Δ_{Start}	D Δ_{End}	E Width c [mm]	F Thickness t [mm]	G Description	H Symbol	I Value	J Unit	K
5	6,7,8	Both sides	1.2	1.2	147.5	2.5	Normal stress	$\sigma_{x, start}$	-115.2	N/mm ²	
							Normal stress	$\sigma_{x, End}$	-95.4	N/mm ²	
							Boundary stress	σ_1	115.2	N/mm ²	
							Boundary stress	σ_2	95.4	N/mm ²	
							Stress ratio	ψ	0.918	-	
							Buckling factor	k_{σ}	4.167	-	
							Euler. relative stress	σ_e	54.5	N/mm ²	
							Max. compression stress	σ	115.2	N/mm ²	
							Plate slenderness	$\lambda_{p, \sigma}$	1.028	-	
							Reduction factor	ρ	0.769	-	
							Effective width	b_{eff}	113.4	mm	
							Effective width	b_{e1}	55.5	mm	
							Effective width	b_{e2}	57.8	mm	
	Class of the cross-section									4	

Figure 7.22: Table 5.1 Effective Widths according to EN 1993-1

Zone Number

The results of the effective width design are listed by numbers of the c/t zones.

Elements

This column lists all elements that belong to each c/t zone.

Restraint Type

This column gives information on the restraints of each c/t zone as per definition in table 1.6 c/t Zones (cf 5.6, page 82). They can be supported on one side only (outstand flange) or on both sides (internal compression part).

Subtracted Length Δ_{Start} / Δ_{End}

In these two columns, the distances of the restraint from the start resp. end nodes of the relevant elements are listed. Those values correspond to the lengths as defined in columns E and F of table 1.6 c/t Zones (cf 5.6, page 82).

Width c

The total width of a c/t zone is made up of the lengths of all contained elements which is reduced by the subtracted lengths at the start and end of this zone.

Thickness t

The thickness is defined as the smallest thickness of all elements which are integral parts of the c/t zone.

Description

In this column, the various parameters are listed that are essential to determine the effective widths. If the c/t zone is subject to tensile stresses, the remark *No compression* is indicated instead.

Normal Stresses $\sigma_{x,Start}$ / $\sigma_{x,End}$

These two lines give information on the normal stresses at the start resp. end nodes of each c/t zone. Please note that those are the stresses of the gross cross-section. Tensile stresses are positive, compressive stresses negative.

Boundary Stresses σ_1 / σ_2

These stresses are determined from the normal stresses. σ_1 is the maximum value of the compressive stress at either the start node or the end node of the c/t zone. Accordingly, σ_2 represents the minimum value of both stresses. Additionally, the signs are reversed, i.e. compressive stresses are set positive and tensile stresses are set negative.

Stress Ratio ψ

This line contains the ratio of the values from the two previous lines. If there are tensile stresses at both ends, no values of the stress ratio are determined.

Buckling Factor k_σ

The buckling factor is specified in EN 1993-1-5, Table 4.1 and Table 4.2 (cf Figure 7.23, page 137). To determine k_σ in these tables, the restraint type and the stress ratio have to be considered.

Euler Relative Stress σ_e

This value is calculated according to the following equation:

$$\sigma_e = 189800 \cdot \left(\frac{t}{c}\right)^2 \quad [\text{N/mm}^2]$$

Equation 7.91

Maximum Compressive Stress σ

In this line, the maximum value of the compression stress is specified.

Plate Slenderness $\bar{\lambda}_{p,\sigma}$

The related plate slenderness of the metal sheet for buckling is determined according to EN 1993-1-5, section 4.4:

$$\bar{\lambda}_{p,\sigma} = \frac{c}{28.4 \cdot t} \cdot \sqrt{\frac{f_y}{235 \cdot k_\sigma}} \quad f_y \text{ in } [\text{N/mm}^2]$$

Equation 7.92

Reduction Factor ρ

Different reduction factors have to be considered for either internal compression parts or outstand flanges (cf EN 1993-1-5, section 4.4).

- Internal compression elements

$$\rho = 1.0 \quad \text{for } \bar{\lambda}_{p,\sigma} \leq 0.673$$

$$\rho = \frac{\bar{\lambda}_{p,\sigma} - 0.055 \cdot (3 + \psi)}{\bar{\lambda}_{p,\sigma}^2} \leq 1.0 \quad \text{for } \bar{\lambda}_{p,\sigma} > 0.673 \text{ and } (3 + \psi) \geq 0$$

Equation 7.93

- Outstand compression elements

$$\rho = 1.0 \quad \text{for } \bar{\lambda}_{p,\sigma} \leq 0.748$$

$$\rho = \frac{\bar{\lambda}_{p,\sigma} - 0.188}{\bar{\lambda}_{p,\sigma}^2} \leq 1.0 \quad \text{for } \bar{\lambda}_{p,\sigma} > 0.748$$

Equation 7.94

Effective Width b_{eff} / b_{e1} / b_{e2}

The effective widths are determined as specified in EN 1993-1-5, Table 4.1 and Table 4.2.

Internal compression elements

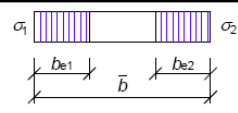
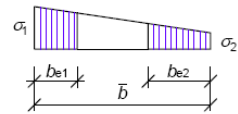
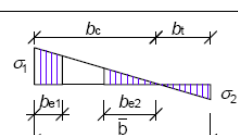
Stress distribution (compression positive)				Effective ^p width b_{eff}		
				$\psi = 1:$ $b_{eff} = \rho \bar{b}$ $b_{e1} = 0,5 b_{eff} \quad b_{e2} = 0,5 b_{eff}$		
				$1 > \psi \geq 0:$ $b_{eff} = \rho \bar{b}$ $b_{e1} = \frac{2}{5 - \psi} b_{eff} \quad b_{e2} = b_{eff} - b_{e1}$		
				$\psi < 0:$ $b_{eff} = \rho b_c = \rho \bar{b} / (1 - \psi)$ $b_{e1} = 0,4 b_{eff} \quad b_{e2} = 0,6 b_{eff}$		
$\psi = \sigma_2 / \sigma_1$	1	$1 > \psi > 0$	0	$0 > \psi > -1$	-1	$-1 > \psi > -3$
Buckling factor k_σ	4,0	$8,2 / (1,05 + \psi)$	7,81	$7,81 - 6,29\psi + 9,78\psi^2$	23,9	$5,98 (1 - \psi)^2$

Outstand compression elements

Stress distribution (compression positive)		Effective ^o width b_{eff}			
		$1 > \psi \geq 0:$ $b_{eff} = \rho c$			
		$\psi < 0:$ $b_{eff} = \rho b_c = \rho c / (1 - \psi)$			
$\psi = \sigma_2 / \sigma_1$	1	0	-1	$1 \geq \psi \geq -3$	
Buckling factor k_σ	0,43	0,57	0,85	$0,57 - 0,21\psi + 0,07\psi^2$	
		$1 > \psi \geq 0:$ $b_{eff} = \rho c$			
		$\psi < 0:$ $b_{eff} = \rho b_c = \rho c / (1 - \psi)$			
$\psi = \sigma_2 / \sigma_1$	1	$1 > \psi > 0$	0	$0 > \psi > -1$	-1
Buckling factor k_σ	0,43	$0,578 / (\psi + 0,34)$	1,70	$1,7 - 5\psi + 17,1\psi^2$	

Figure 7.23: Effective Widths according to EN 1993-1-5

Symbol

This column lists the symbols that are associated with the previous descriptions of the parameters.

Value

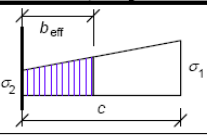
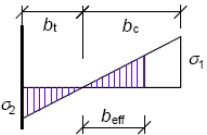
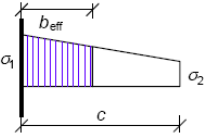
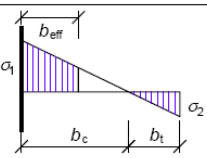
In this column, the numerical values of the various output parameters are listed.

Unit

This column contains the respective units of all output parameters.

8. Results Evaluation

8.1 Results Selection

After the calculation, the numerical output is presented in the various results tables that are described in chapter 7 *Results*. The results can also be evaluated graphically via the **Results** menu or the corresponding buttons in the *Results* toolbar.

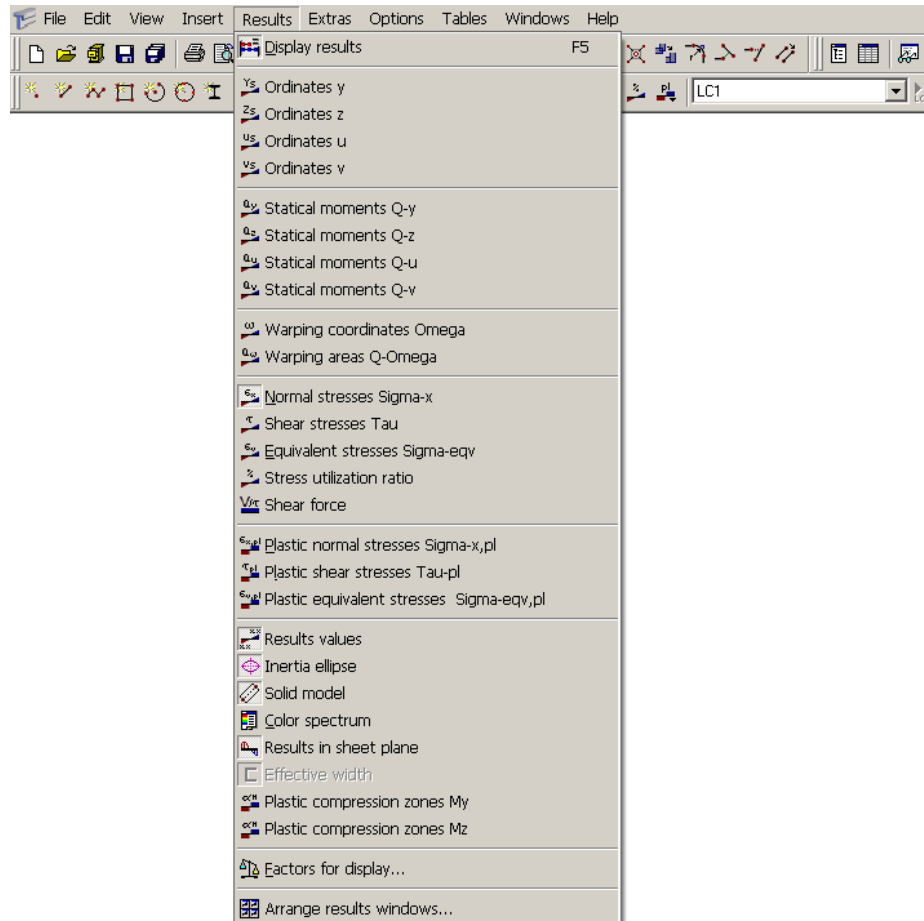

Figure 8.1: Results menu

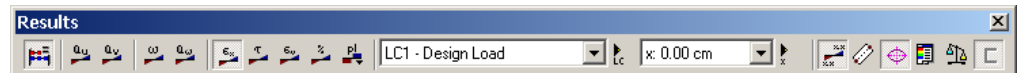
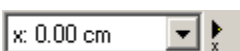
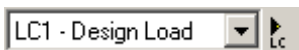

Figure 8.2: Results toolbar

The button [Display results] switches the graphical results on or off, the [Values] button (next the list of locations x) controls the display of the results values in the diagrams.

The load case or location x can be selected from the list in the toolbar. The graphics and – if applicable – the tables are updated automatically.



8.2 Results Display

As described in the previous chapter, the selection of the results can be controlled via the *Results* menu or the *Results* toolbar.

The diagrams of the section characteristics or stresses are displayed two colored by default. This type of display can be advantageous for printing. Positive results are drawn as cyan lines, and negative ones as red lines.



If the result diagrams overlap for many elements, the lines can also be arranged orthogonally to the elements via the button as seen to the left. Thus, the view of the results can be improved for certain sections.

The parameters of the diagrams can be controlled in the *Settings* dialog box, tab *Results*. This dialog box is called up via menu

Options → Viewing Options

or the global context menu which can be activated by a right-mouse click in the work area.

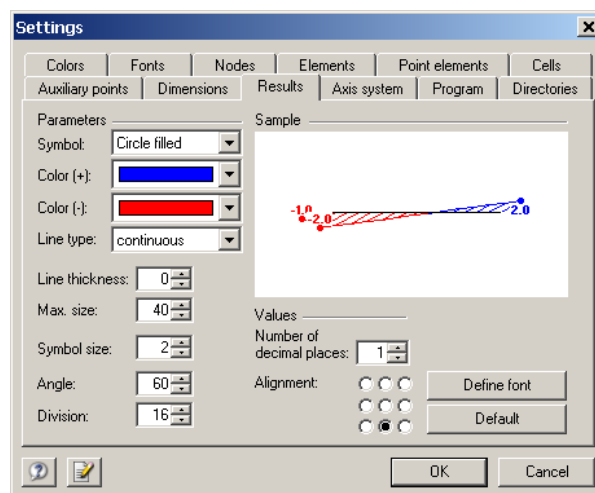

Figure 8.3: Dialog box *Settings*, *Results* tab

The editing options include the colors, line thickness and fonts of the results display which allow for a user-defined tuning of the results graphics.



It is also possible to apply a multi-color display of the results that can be activated via menu

Results → Color spectrum

or the corresponding button in the toolbar.

The colors of the lines are then allocated according to the spectrum of the control panel. Details on how to adjust this color spectrum can be found in chapter 4.3.6 on page 40.

As can be seen in the following image, there are two options available in the control panel. For the *Distribution* of the results diagrams, eleven colors are utilized for the lines instead of two. The option *Isosurfaces*, however, transfers the graphical results on the element thicknesses of the section.

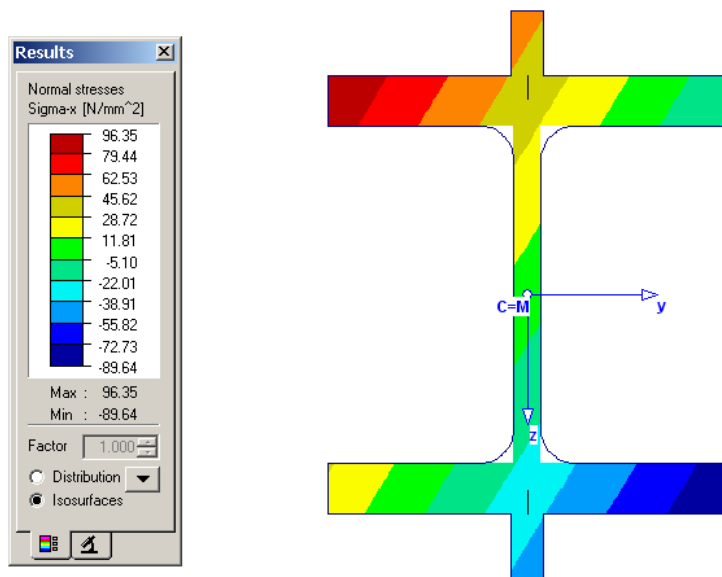

Figure 8.4: Multi-color results as *Isosurfaces* and color spectrum



For the two- or multi-color line display, the scaling of the results diagrams can be controlled via the [Display factor] button. This function is also accessible in the *Results* menu. It calls up a dialog box which allows for a user-defined scaling of the diagrams.

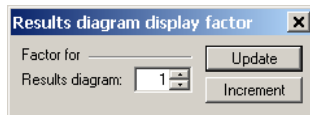

Figure 8.5: Dialog box *Results Diagrams Display Factor*



The *Filter* tab of the control panel can be used to select specific elements whose results are to be displayed exclusively. For details, see chapter 4.3.6 on page 42.

As usual, the items that are to be displayed can be controlled in the *Display* dialog box which is called up via menu

View → Display.

Activate the category *Results* for a detailed selection of the objects among this *Subcategory* that are to be shown in the results graphics.

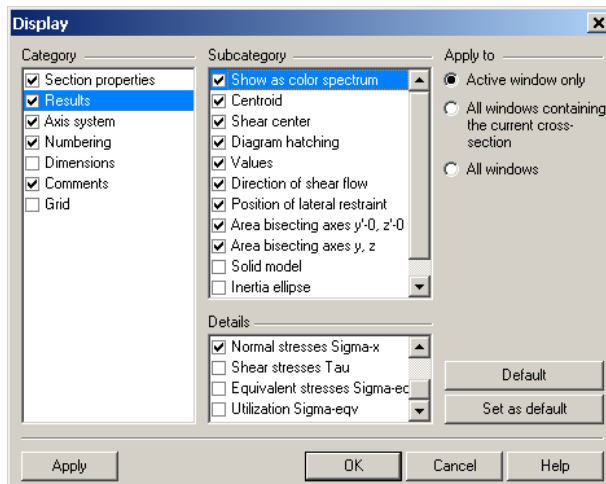

Figure 8.6: Dialog box *Display*, category *Results*

8.3 Results Values



Define font

The [Values] button, located next the list of locations x, controls the display of the results values in the diagrams.

The viewing options of the *Settings* dialog box control the locations of the results values and their display (cf Figure 8.3, page 139). Via the [Define font] button in this dialog box, the fonts, font styles and sizes of the values can be modified.

It is also possible to directly read various object or results data by placing the mouse pointer on the desired object or location of the element. After a short while, the tooltip appears.

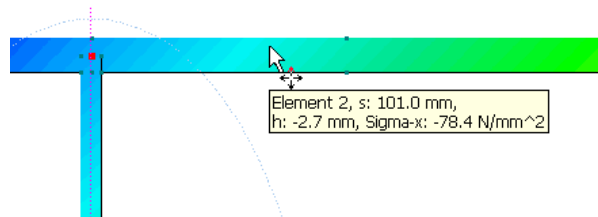

Figure 8.7: Tooltip of an element (stresses σ_x displayed as isosurfaces)

In the tooltip shown above, the parameter *s* represents the distance from the element start, *h* the distance from the center line of the element.



Detailed information on specific elements can be obtained via the *Element Info* function. It is activated via menu

Extras → Element info

or the corresponding button in the toolbar.

The *Element results* dialog box appears. When the mouse pointer is placed on an element, essential data on the element and its results can be read.

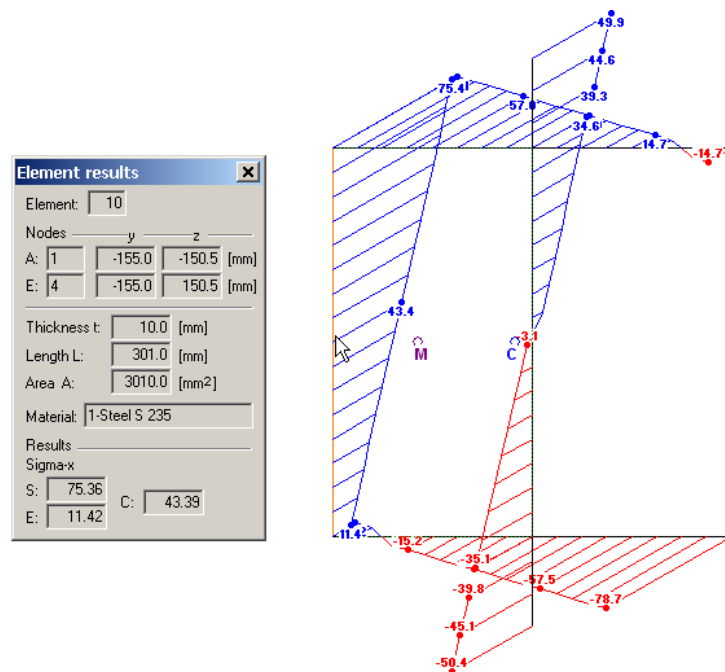

Figure 8.8: Dialog box *Element results* showing normal stresses of specific element

The results are listed of the start (S) and end (E) nodes of the element. Additionally, the result value of the element center (C) is indicated.



If plastic stresses are displayed in the graphics, the *Particle info* dialog box is called up instead. There, the characteristics of the Simplex element that is identified by the location of mouse pointer.

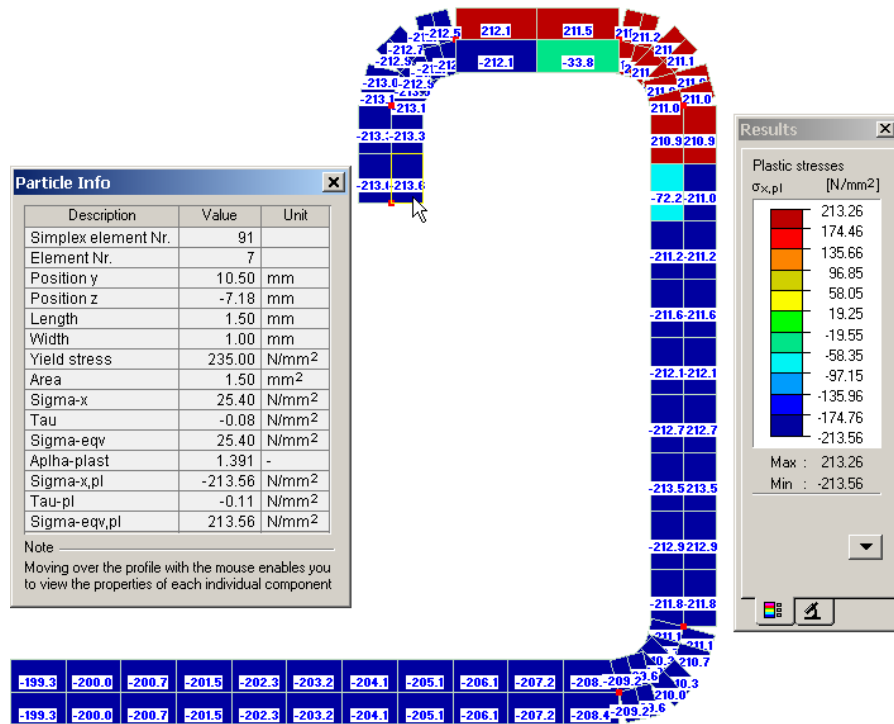

Figure 8.9: Dialog box *Particle Info* showing characteristics of specific Simplex element

8.4 Multiple Windows View



Several windows can be viewed together with different section characteristics or stresses at the same time. This option can be activated via menu

Results → Arrange results windows

or the corresponding button in the toolbar.

A dialog box opens where the different types of results can be selected.

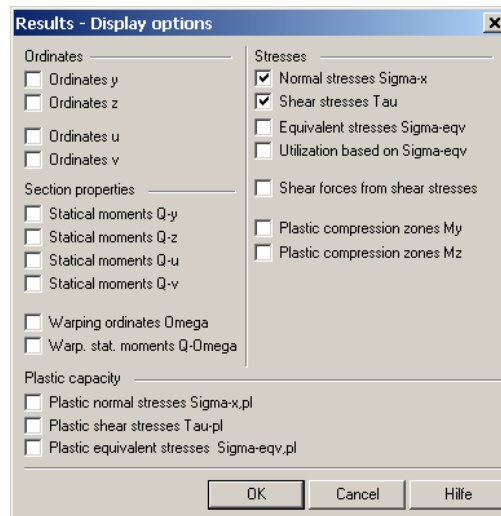

Figure 8.10: Dialog box *Results - Display options*

The multiple window view can also be used for the printout (cf chapter 9.2 on page 162).

8.5 Filter Results

There are several filter options for a better overview over the results. They can also be suited for the following documentation of the results.

Groupings

With groupings, it is possible to split the section into components graphically. The partial view functions are available in menu

View → Create grouping etc.

or the corresponding button in the toolbar.

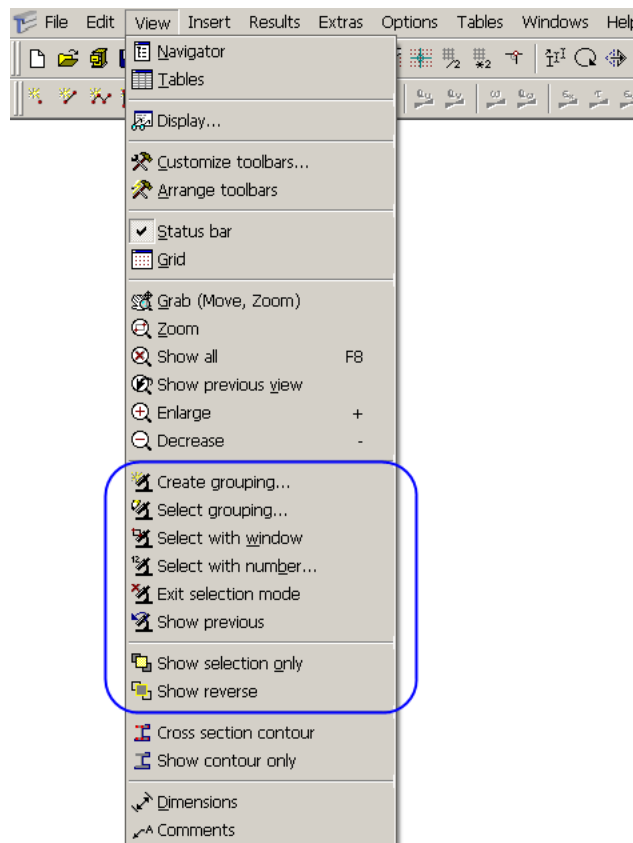

Figure 8.11: Menu View → Groupings

Create Grouping

If you have selected certain objects, you can save them as a so-called *Grouping*.

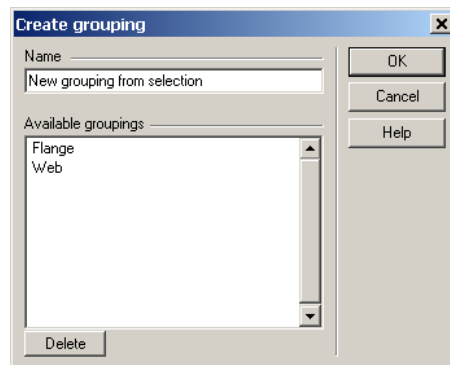

Figure 8.12: Dialog box Create grouping

In the dialog box, you have to define the *Name* of the partial view before this group of objects can be stored.

The menu function **Edit** → **Select** → **Special** can be useful to select objects. In a dialog box, detailed settings for the selection are possible (cf chapter 10.1.2, page 167).

Select Grouping

All defined partial views will be listed. SHAPE automatically creates partial views arranged by sections and materials.

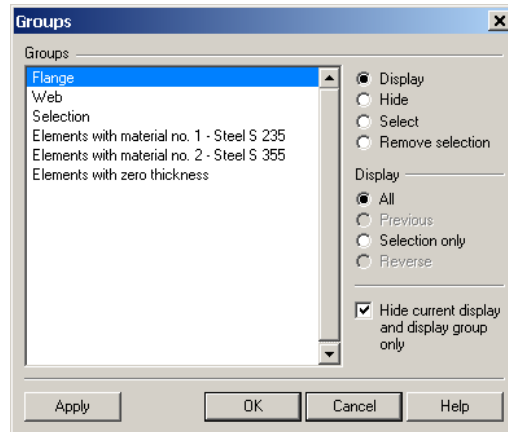

Figure 8.13: Dialog box *Select Grouping*

Grouping via Window

Partial views can also be created via the mouse by pulling up a window.

If you pull up the window from the left to the right, the partial view contains only objects that are completely within this window. If you pull up the window from the right to the left, the partial view contains also those objects that are cut by the window.



Grouping via Number

The numbers of objects for the partial view can be defined in a dialog box.

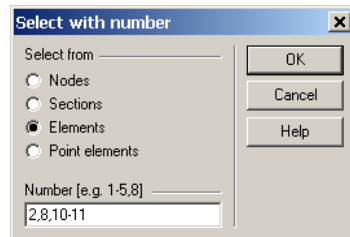

Figure 8.14: Dialog box *Select with number*

Exit Partial View Mode

This function restores the view of all objects.



Sections

Sections can be useful to filter results. They are also included in the list of groupings. Details on the sections can be found in chapter 5.3 (p. 73) and in chapter 10.1.8 (p. 171).



Filter Functions

The filter options shown above refer to the objects of the cross-section. It is also possible to use the section characteristics or stresses as selection criteria.

Filter Stresses



The panel has to be displayed to filter the internal forces in a structure. If it is not shown, activate it via menu *Results* → *Color Spectrum* or the button as seen to the left.

Details on the control panel can be found in chapter 4.3.6 on page 40. The filter settings for the results have to be done in the *Color Spectrum* tab. It can be defined that e.g. shear stresses exceeding 50 N/mm² or normal stresses within the interval of ±20 N/mm² are to be displayed in detail (cf Figure 4.14 on page 41).

In the following example, the equivalent stresses between 120 N/mm² and 220 N/mm² are displayed exclusively. The spectrum has also been modified in a way that one color range covers exactly 10 N/mm². Stresses that do not fulfill these conditions will not be shown.

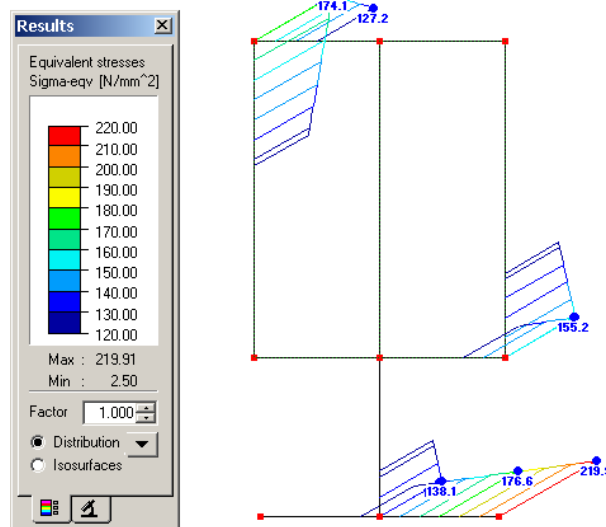

Figure 8.15: Filtering equivalent stresses with adjusted color spectrum

Filter Elements



In the *Filter* tab of the control panel, you can define the numbers of those elements whose results are to be shown exclusively in the graphics. Details on these functions can be found in chapter 4.3.6 on page 42.

Unlike the *Grouping* function, the section is shown completely. The following image shows the normal stresses of the flanges. The webs are displayed, too, but without any stresses.

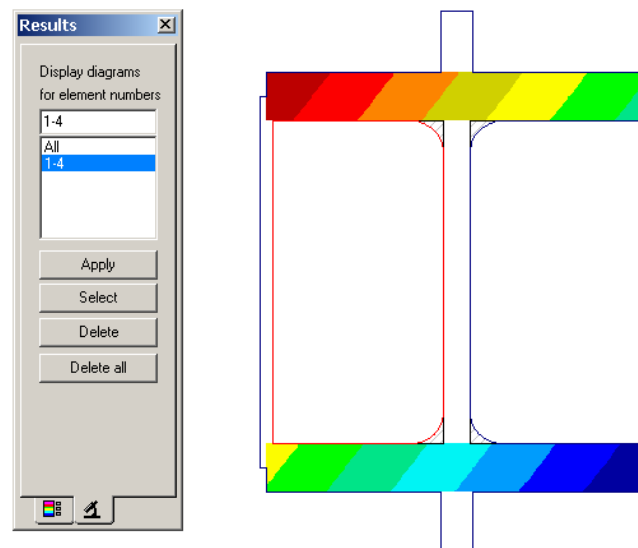

Figure 8.16: Filtering *Elements*: Normal stresses of the flanges

9. Printout

9.1 Printout Report

Instead of sending the data directly to the printer, it is recommended to create a so-called *printout report* from the input and results data first. It can be supplemented with graphics, explanations, scans, and other elements. In this printout report, you can also define which sectional data is to be included in the final printout.

For every section, several printout reports can be created. It is possible to create different printout reports for a SHAPE section. Depending on which data is needed, e.g. the design engineer and the detailer might receive different printout reports.

A printout report can only be called up if a default printer has been installed in Windows. The preview in the printout report uses this printer driver.

9.1.1 Create or Open Printout Report

A new printout report can be created via menu

File → **Printout report**,

the button in the toolbar, or the context menu in the navigator.

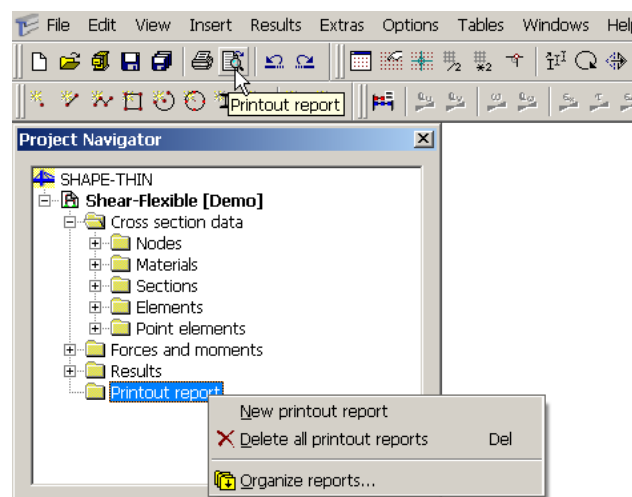

Figure 9.1: Button and context menu *Printout report*

The following dialog box is opened.

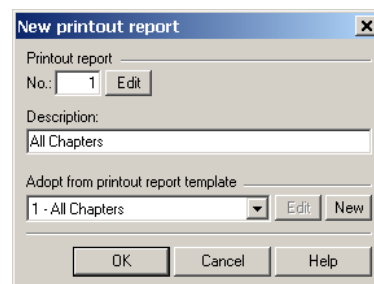

Figure 9.2: Dialog box *New Printout Report*

The number of the report is preset by the program but can be modified in the *No.* input field. In the input field *Description*, you can enter a name for the report which makes the selection in the lists easier. This description will not be printed.

From the list under *Adopt from printout report template*, you can select a specific report template. Details on the templates can be found in chapter 9.1.7 on page 157.

The buttons in this dialog box have the following functions:



	A new report template can be created.
	The selection of report can be changed (→ chapter 9.1.3, page 149).

Table 9.1: Buttons in dialog box *New Printout Report*



If a printout report has already been defined, it can be opened via menu **File → Printout Report**, the corresponding button in the toolbar, or by double-clicking it in the navigator.

9.1.2 Work in Printout Report

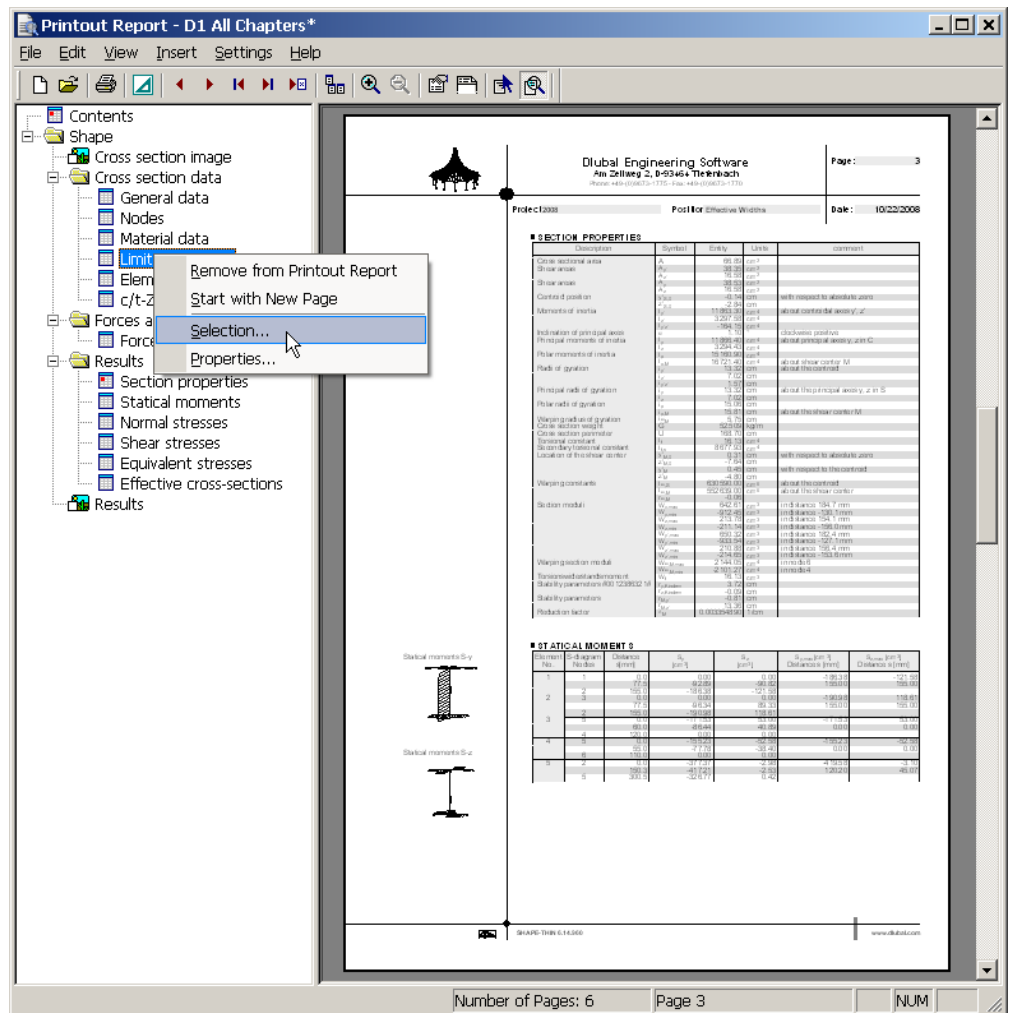

Figure 9.3: Printout report with context menu

If the printout report has been created, a navigator is shown on the left. On the right, the preview of the printout is presented.

The individual chapters can be moved in the navigator to any place by drag & drop.

The context menu offers additional options for the printout report. As usual for Windows applications, multiple selections are possible.

Remove from Printout Report

The selected chapter will be deleted. The global selection makes it possible to reinsert this chapter again (menu *Edit* → *Global Selection*).

Start with New Page

The selected chapter starts on a new page. It is marked by a red pin in the navigator.



Selection

The global selection dialog box opens (see following pages) where the selected chapter will be set by default.

Properties

The general properties of a chapter can be modified as shown in the following figure.

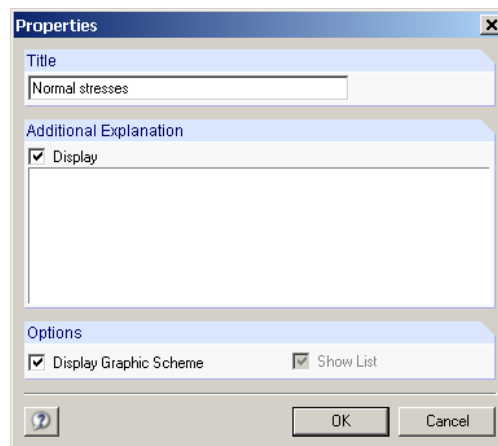









Figure 9.4: Dialog box *Properties*

Here you can change the *Title* of the chapter and enter an *Additional Explanation* which will then be displayed on the left margin of the report. This additional text as well as the accompanying *Graphic Scheme* (informative picture of cross-section or stress distribution) can be hidden. The check box *Show List* controls whether the number list of reduced chapter data (e.g. selected elements) will be displayed in the navigator and in the table of contents.

Navigation in the Printout Report

The easiest way to navigate to a specific page of the printout report is by clicking on the relevant chapter in the navigator. In the **View** menu, you have additional functions which can also be opened with the following buttons.

	Go to previous page in the preview
	Go to next page
	Go to first page
	Go to last page
	Enter page number that is to be displayed
	Switch between one sided and double sided view
	Zoom in
	Zoom out



	Selection Mode: Mouse clicks selects a chapter and open the selection dialog box
	Zoom Mode: Mouse click zooms in on selected chapter
	Redraw the view of the printout report

Table 9.2: Navigation buttons in the printout report toolbar *View*

9.1.3 Define Contents of Printout Report



In the global selection, the chapters are selected that are to be contained in the printout report. This function can be called up via menu

Edit → **Global Selection**,

the corresponding button in the toolbar, or the *Contents* context menu.

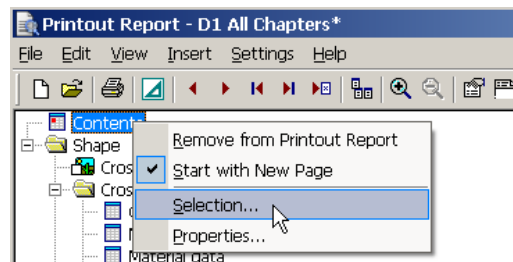

Figure 9.5: Opening the global selection via the *Contents* context menu.

The following dialog box will be displayed.

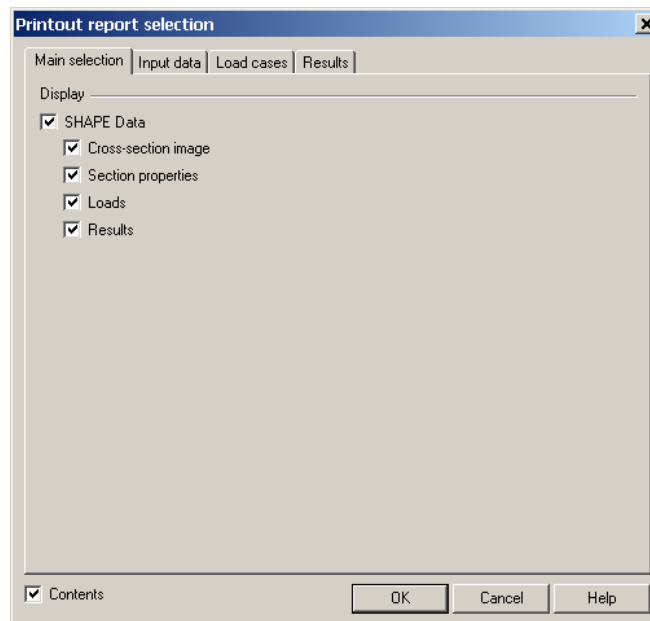

Figure 9.6: Dialog box *Printout report selection*, *Main selection* tab

The *Main Selection* tab controls the main chapters of the printout report. If a check box is deactivated there, the tab with its details will disappear, too.

A full-page *Cross-section image* incl. dimension lines and principal axes will be inserted in front of the sectional data if the respective check box is activated.

9.1.3.1 Select Section Data

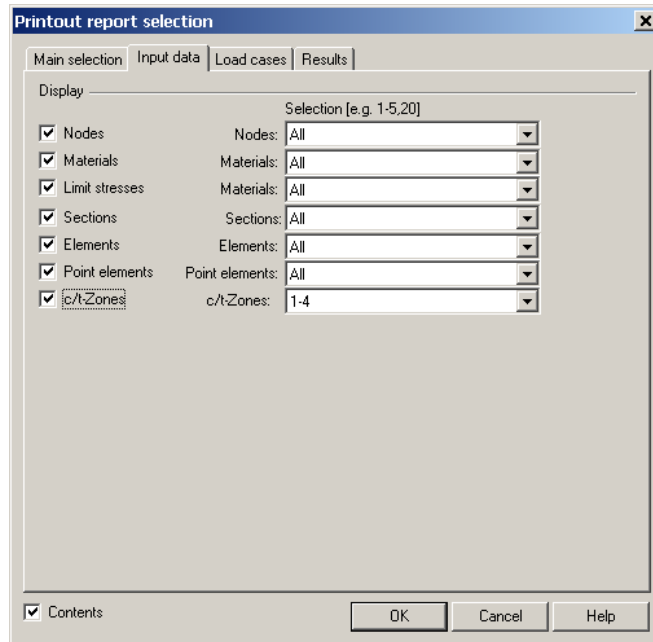

Figure 9.7: Dialog box *Printout report selection*, *Input data* tab

The *Display* column controls whether a chapter is to be included in the printout report.



The printout report is based on the input tables (cf chapter 5). The *Selection* column controls which table lines are to be included. By default, *All* objects are listed in the printout report. For a specific numerical selection, click the [▼] button at the end of the relevant input field to open a new, empty line. Then activate this line by a mouse click and insert the numbers of the specific objects.

9.1.3.2 Select Load Data

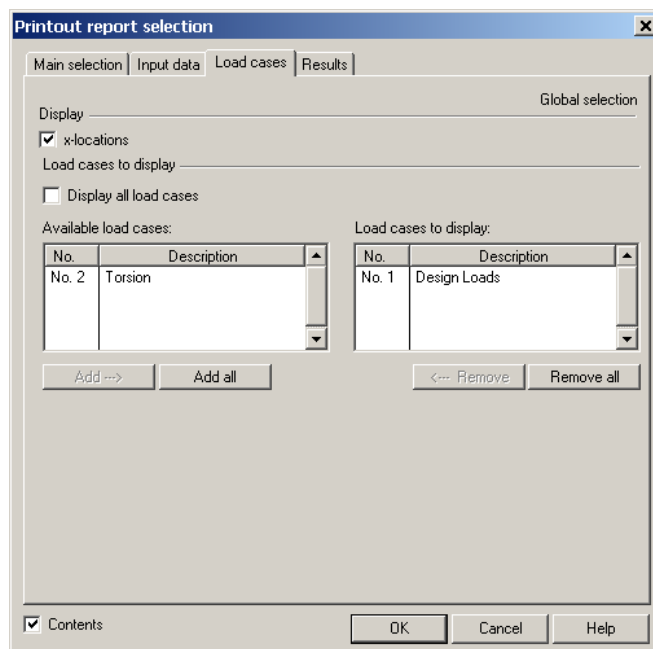
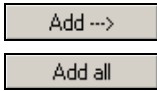

Figure 9.8: Dialog box *Printout report selection*, *Load cases* tab

The same procedure as for the selection of the sectional input data applies to these tables.

If the *Locations x* are set active, the input data of table 1.7 *Forces and moments* will be included in the printout report.

The check box *Display all load cases* controls whether the internal forces of all or only of specific load cases are to be printed. If you deactivate this option, you can select the relevant load cases via the two [Add] buttons beneath the list of *Available load cases*. Those will be transferred to the dialog section *Load cases to display*. It is also possible to select (and to deselect) a load case by double-clicking it.



9.1.3.3 Select Results

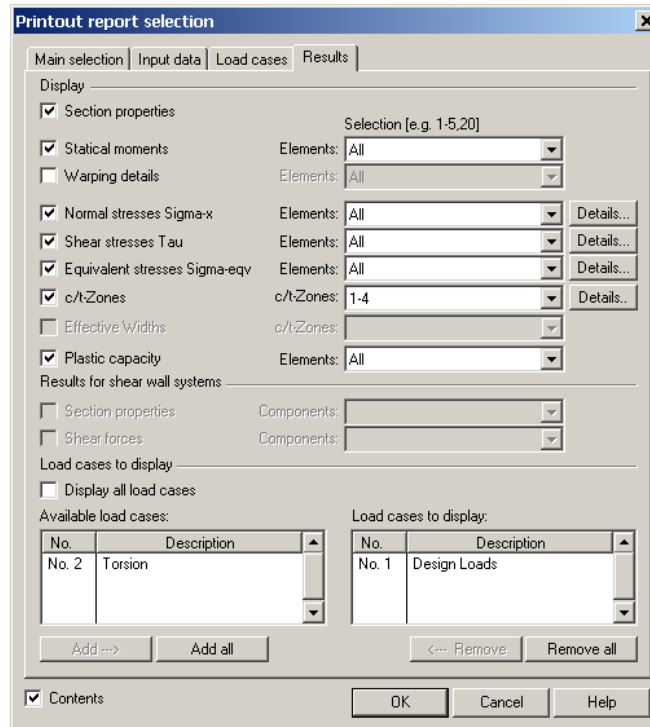

Figure 9.9: Dialog box *Printout Report Selection, Results* tab



Selecting the results data is similar to choosing the sectional input or load data. The table lines of the respective results tables (cf chapter 7) can be selected in the same way as those of the input data: For a specific numerical *Selection*, click the [▼] button at the end of the relevant input field to open a new, empty line. Then you can insert the numbers of the relevant objects.



For the stresses and *c/t* zones, the [Details] button allows for a specific control on the results data.

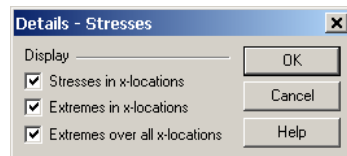
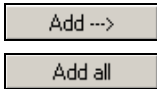

Figure 9.10: Dialog box *Details - Stresses*

Here you can choose whether all stresses of the locations *x* and/or only the maximum and minimum results are to be printed. The same applies to the *c/t* zones: It can be defined whether all *c/t* zones or only the decisive ones are to be included, which allows for reducing the printed contents.



In the dialog section *Load cases to display*, the printout can be confined to the results of specific load cases. If you deactivate the option *Display all load cases*, the relevant load cases can be selected via the two [Add] buttons beneath the list of *Available load cases*. Those will be transferred to the dialog section *Load cases to display*. It is also possible to select (and to deselect) a load case by double-clicking it.

9.1.4 Adjust Printout Report Header



Already during the installation, SHAPE creates a print header from the customer data. This default header can be changed via the printout report menu

Settings → Header

or the corresponding button in the toolbar of the printout report.

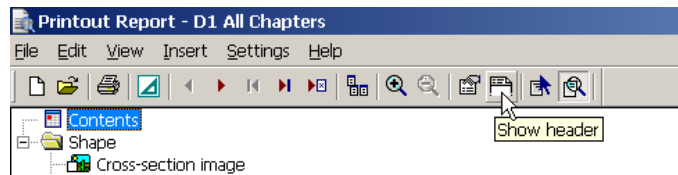

Figure 9.11: Button *Show header*

In the following dialog box, all settings for the printout header can be defined.

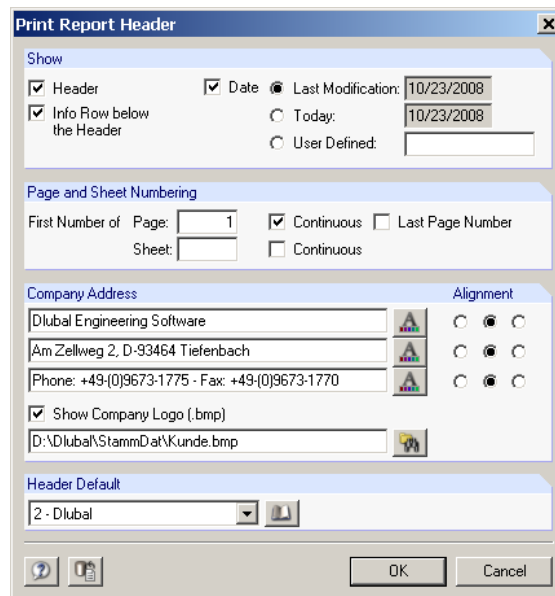

Figure 9.12: Dialog box *Print Report Header*

The dialog section *Show* specifies which elements of the header are shown and which *Date* is to be printed.

The option *Info Row below the Header* includes the general project and sectional data together with the date.

The *Project Description* is managed in the Project Manager among the general data of the project where it can be edited (cf chapter 4.4.1.1, page 49). The *Section Description* can be edited in the general data of the section (cf chapter 4.4.2.1, page 54).

The numbering can be adjusted in section *Page and Sheet Numbering*. If *Page* and *Sheet* have the same initial number, there is no difference in the numbering. But if you e.g. want to assign all pages to one sheet, then the sheet numbering is to be deactivated.

The check box *Continuous* defines whether the numbering is to be automatically increasing. The first number of the page and sheet numbering can be defined manually. The check box *Last page number* controls whether the number of the final page is added (e.g. *Page: 4/17*).



The section *Company Address* in the *Header* dialog box contains the customer data which can be edited here. There are three input fields available, one for each header line. Via the button [A], you can define the font for the selected line. The *Alignment* of the lines can also be defined individually.



You can also include the company logo as a graphical object in the left area of the header. This image must be a bitmap file. With graphics programs like e.g. MS Paint, you can save every image as a *.bmp file.



If you want to save the edited print header, click the [Set Header as Default] button that is located beneath the *Header Default* section. The dialog box *Header Template Name* appears where a name can be entered. This print header will then be the default setting in the list.



The [Header Library] button is recommended if you want to store or manage different print headers. It calls up following dialog box.

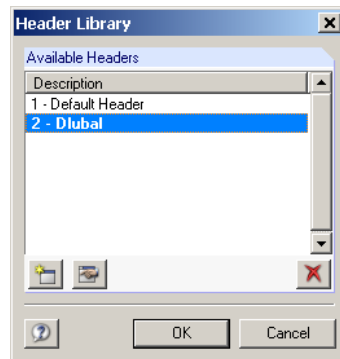

Figure 9.13: Dialog box *Header Library*

This dialog box is used to create, edit or delete the print header template. The functions of the buttons are as follows:



	A new header can be created. An additional dialog box allows for the data input.
	The selected header can be edited.
	The selected header will be deleted.

Table 9.3: Buttons in *Header Library* dialog box



If several headers are available, one of these can be selected in the *Header Default* dialog section. The button [Set as Default] applies this header to the printout reports of subsequent cross-sections.



The print headers are stored in the file **DlubalProtocolConfig.cfg** which is located in the common data file (e.g. C:\Program Files\Dlubal\Stammdat). Although this file is not overwritten by the installation routine, a backup copy might be advisable.

9.1.5 Insert Section Images



Every sectional image can be included in the printout report. The current SHAPE graphics is printed via menu

File → Print

or the corresponding button in the toolbar.

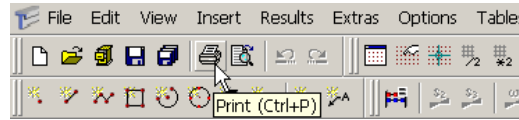

Figure 9.14: Button *Print* in the toolbar of the main window

The following dialog box is displayed:

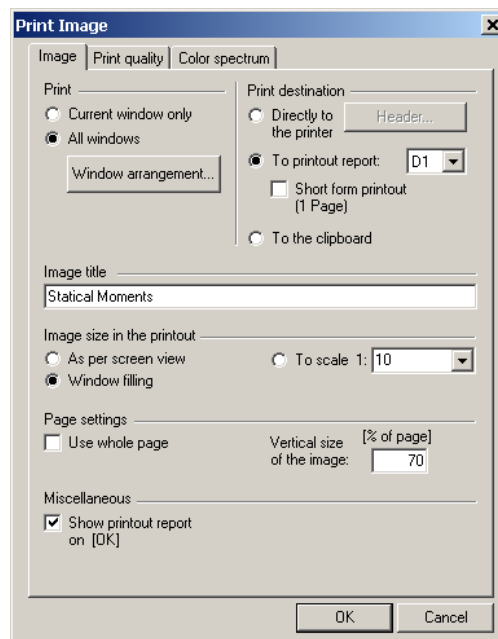

Figure 9.15: Dialog box *Print Image*, *Image* tab

In the *Print Image* dialog box, the option *To printout report* is to be selected. If more than one printout report exist, you can choose the number of the relevant report from the list next to the selection field.



For the printout report, dynamical images will be generated. This means that the graphics in the printout will be updated automatically according to changes in the section or results.

When the dialog box is closed with [OK], the printout report will be opened. In some cases this may not be desirable, e.g. when you want to print several images one after another. By deactivating the check box *Show printout report on [OK]*, it is possible to prevent the report from being opened.

Details on the remaining functions (e.g. the *Short form printout* option) in this dialog box can be found in chapter 9.2 on page 161.

9.1.6 Insert Graphics and Texts

There are various options to include any kind of images and texts in the printout report.

Insert Graphics

If you want to add an image that is not a SHAPE picture itself, you first need to open this graphic file in an image editor (e.g. MS Paint). There the image has to be copied to the clipboard via [Ctrl]+[C].

The image can then be inserted via the printout report menu

Insert → **Picture from Clipboard**.

Before it will be included, the chapter name is to be entered.

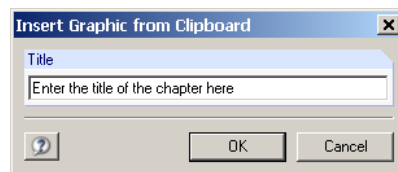

Figure 9.16: Dialog box *Insert Graphic from Clipboard*

This image will appear as a single chapter in the printout report.

Insert Texts

Short notes can also be added to the printout. This function is activated via menu

Insert → **Text**.

The following dialog box will be displayed.

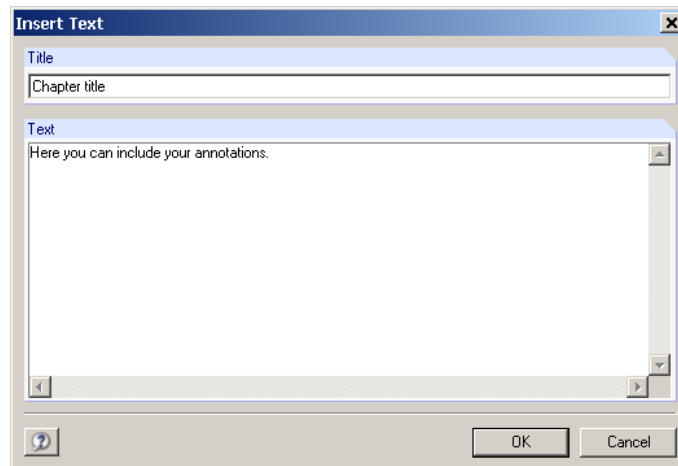

Figure 9.17: Dialog box *Insert Text*

Enter here a *Title* and the *Text*. With the [Enter] key you can define a manual word-wrap in this text.

After [OK], the chapter will be added to the printout report. You can move it to the desired position by Drag & Drop.

In the selection mode, the text can be modified by double-clicking it or by right-mouse-clicking its header in the navigator and then selecting *Properties* in the context menu.



Insert Texts from Text Files

You can also insert text files in the printout report. Recurrent texts can be stored in a file and in this way be used for the report. With this function, you can also integrate data of other programs, provided that these are ASCII text files.

Text files are imported via the printout report menu

Insert → **ASCII File**.

In the Windows dialog box *Open*, you first select the file. Before the file contents will be imported, an extra dialog box appears.

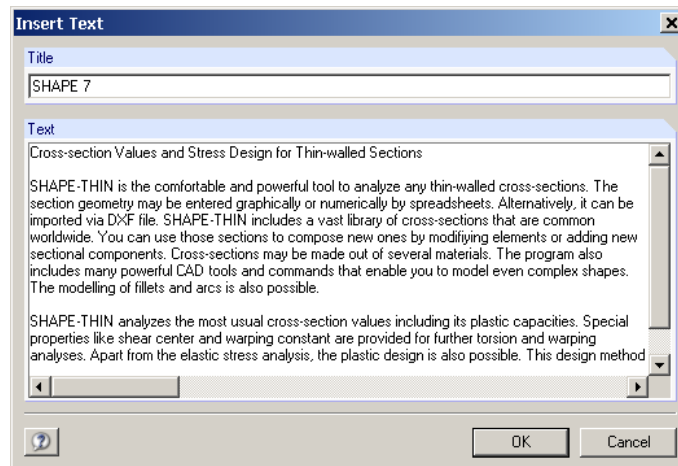

Figure 9.18: Dialog box *Insert Text*

You can still adjust the *Text* here and define a chapter *Title*.

After [OK], the chapter will be added to the printout report. You can move it to the desired position by Drag & Drop.

In the selection mode, the text can be edited by double-clicking it.



Insert Texts from RTF Files

The previously described option allows for inserting recurrent texts in the printout report. ASCII files, however, are not formatted texts.

The import of RTF files enables you to integrate formatted texts with embedded graphics in the report. This function can be activated via menu

Insert → **RTF File**.

In the Windows dialog box *Open*, you can select the *.rtf file. Before it can be included in the printout report, you still have to enter the chapter name.

After [OK], the chapter will be added to the printout report. You can move it to the desired position by Drag & Drop.

9.1.7 Printout Report Template

The selection as it is described in chapter 9.1.3 may be time-consuming. You can store the selection including images as a report template to reuse it later for different sections, which makes the creation of printout reports more efficient.

An existing report can be also used as a template subsequently.

Create New Template

A new template can be defined via these menus of the printout report:

- **Settings** → **Printout Report Template** → **New**
- **Settings** → **Printout Report Template** → **New from Current Printout Report**

New

First, the *Printout Report Selection* dialog box is called up (cf Figure 9.6, page 149) where you can select the contents to be printed. When you then close this selection with [OK], you can enter a *Description* for this new report template.

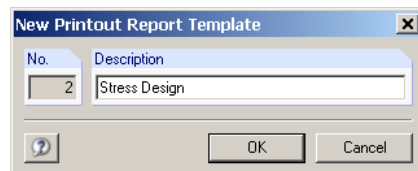

Figure 9.19: Dialog box *New Printout Report Template*

New from Current Printout Report

The selection of the current printout report will be used for the selection of the new template. You only have to enter the *Description* of the report template.

Apply Template

If a printout report has been already opened, the selection of a specific template can be applied to the current report via menu

Settings → **Printout Report Template** → **Select**.

In the following dialog box, the relevant report template can be chosen from the list of *Available Printout Report Templates*.

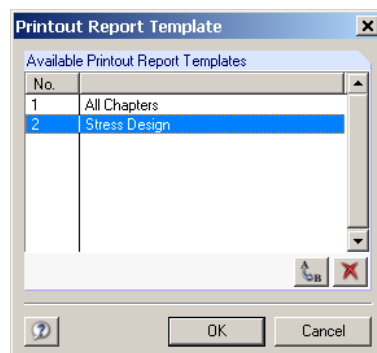

Figure 9.20: Dialog box *Printout Report Template*

After [OK] and confirming again, the current selection will be overwritten by the template.

If a new printout report is created (cf Figure 9.2, page 146), you can select a template from the list *Adopt from printout report template* whose settings are to be applied for the new printout report.

Details on the buttons of this dialog box can be found in Table 9.4.

Manage Templates

The templates are managed in the *Printout Report Template* dialog box (cf Figure 9.20) which is called up via the printout report menu

Settings → **Printout Report Template** → **Select**.

The buttons in this dialog box have the following functions.



	The name of the selected template can be changed.
	The selected template will be deleted.

Table 9.4: Buttons in dialog box *Printout Report Template*

These functions can be applied to user-defined templates only.



You can save your printout report templates before installing an update. These templates are stored in the file **DuenqProtocolConfig.cfg** which is located in the common data folder of SHAPE (e.g. C:\Program Files\Dlubal\DUENQ7\Stammdat). Although this file is not overwritten by the installation routine, a backup copy might be advisable.

9.1.8 Adjust Layout

The layout of a printout report can be adjusted with regard to the fonts and font colors, margin settings and table design.

This dialog box can be activated via the printout report menu

Edit → **Page Setup**.

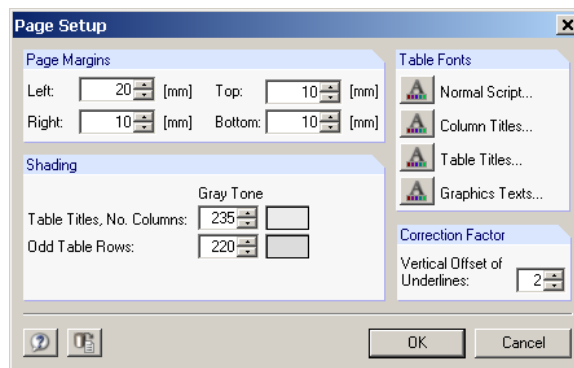

Figure 9.21: Dialog box *Page Setup*



The default fonts of the table contents and the table headers are relatively small. However, you should be careful when changing the default **Arial 8**. Larger fonts do not always fit in the columns.

9.1.9 Print Printout Report



The actual printing process is started via the printout report menu

File → **Print**

or the corresponding button in the toolbar of the printout report.

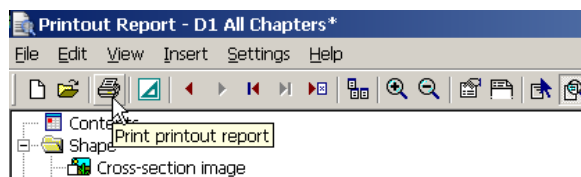

Figure 9.22: Button *Print printout report*

The default printer dialog box opens where the printer and the pages can be defined.

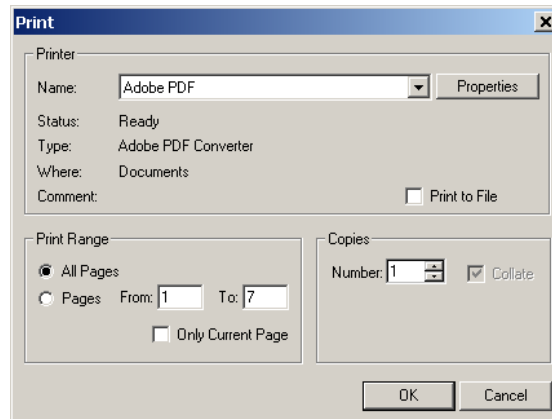

Figure 9.23: Dialog box *Print*

If you do not use the default printer, the page break and, therefore, the page numbers might be different from the print preview.

The option *Print to File* creates a file in the PRN format which can be sent to the printer via the **copy** command.

9.1.10 Export Printout Report

You can directly export the printout report as an RTF file and to the spreadsheet application *BauText*.

RTF Export

The RTF format can be read by all common word processing programs. The printout report will be exported together with the graphics.

The export to an RTF document can be started via the printout report menu

File → **Export to RTF File or BauText**.

The following dialog box appears.

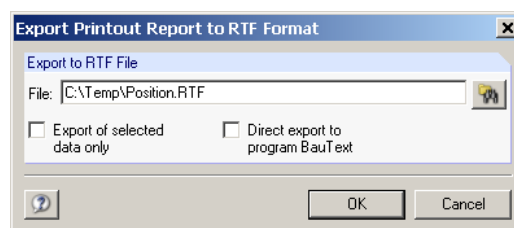

Figure 9.24: Dialog box *Export Printout Report to RTF Format*

The folder and file name of the RTF file have to be defined. When the check box *Export of selected data only* is activated, the selected chapters will be exported instead of the entire report.

BauText Export

BauText is a word processing program with specific extras for structural calculations.

The export to *BauText* can be started via menu

File → **Export to RTF File or BauText**

or the corresponding button in the toolbar of the printout report.

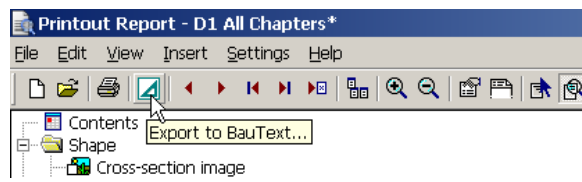

Figure 9.25: Button *BauText*

The dialog box as seen in Figure 9.24 is called up where the check box *Direct Export to BauText* can be activated. It is not necessary to enter a file name, but *BauText* should already be running. After [OK], the *BauText* import module will be started.

PDF Export

The direct export of the printout report to a PDF document is not possible. However, if you have installed the Adobe Acrobat™ or a similar product, then you have a virtual printer in the *Print* dialog box to create a PDF document.

There are also freeware tools to create PDF files, e.g. *Ghostscript* or *Win2PDF*. A printer has to be installed, too, that can print PostScript, e.g. HP Color LaserJet 5/5M PS. If this printer is set that it will print to a file, you can generate a PostScript file from every printout report that can be finally converted into a PDF file by e.g. *GhostScript*.

ASCII File

SHAPE also supports printing to an ASCII file. If you need the data in this format, you can either use the *Export to MS Excel* function in the input and output tables (cf chapter 10.3.6, page 188) or the general SHAPE menu

File → **Export**.

It calls up the Windows *Save as* dialog box which is explained in chapter 11.1 on page 198.

9.1.11 Language Settings

The language settings in the printout report are independent of the language that is set for the SHAPE user interface. In this way, you can create a German printout report with the English version of SHAPE and vice versa.

Change Language of Printout Report

The language of the printout report can be changed via the printout report menu

Settings → **Language**.

In the following dialog box, the desired language can be selected from the list.

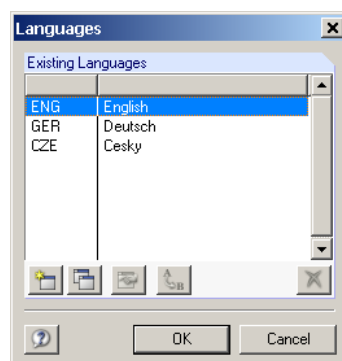
Figure 9.26: Dialog box *Languages*

9.2 Direct Graphic Printout

Every image of the section can be printed directly. This means that you do not need to integrate this picture in the printout report (cf chapter 9.1.5, page 154) to print it.



The current SHAPE image can be printed via menu

File → Print

or the corresponding button in the toolbar.

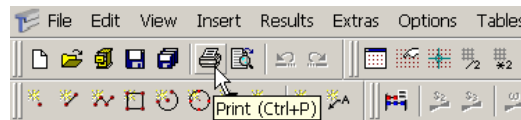

Figure 9.27: Button *Print* in the toolbar

A dialog box is displayed that is split into two (or three) tabs. These are described in the following chapters.

9.2.1 Image

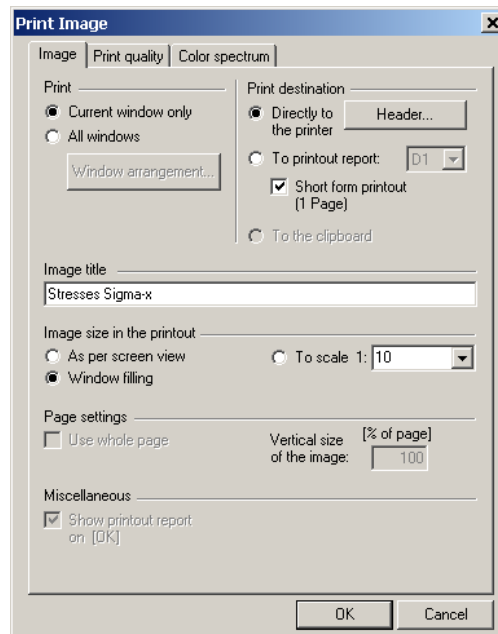

Figure 9.28: Dialog box *Print Image*, *Image* tab

Print

Several graphic windows can be displayed simultaneously in SHAPE (see following image).

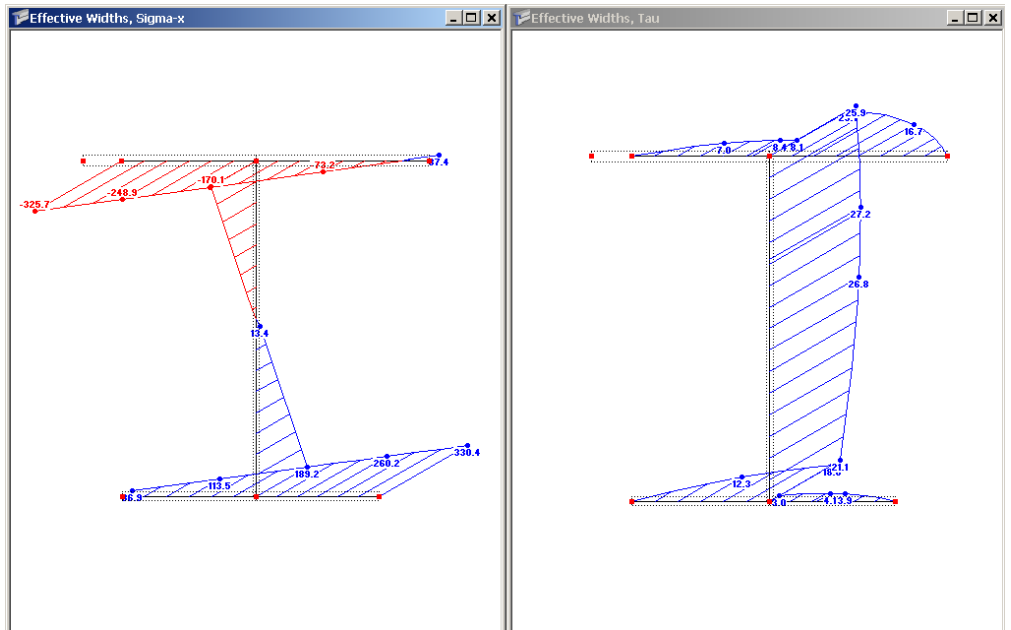

Figure 9.29: Two windows side by side

This dialog section is applicable for multiple windows settings in the printout. The option *Current window only* prints the window in focus, e.g. the left-hand window in Figure 9.29.

When *All windows* has been selected, the [Window arrangement] button becomes accessible to define the layout of the images on the page. The following dialog box opens.

Window arrangement...

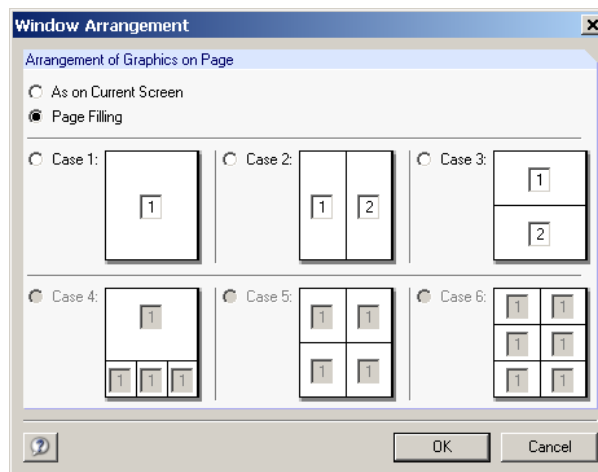

Figure 9.30: Dialog box *Window Arrangement*

Print Destination

Here you can choose between three options for the output of the image:

- Directly to printer
- To printout report (cf chapter 9.1.5, page 154)
- To clipboard

Header...

The option *Directly to Printer* is used for the direct printout. In this case, you can adjust the printed headlines via the [Header] button. The *Print Report Header* dialog box will be opened which is described in chapter 9.1.4 on page 152.

If you select the *Short form printout*, the most relevant sectional characteristics will be condensed on a single page next to the current image(s) of the section (cf Figure 9.31).

When you copy to the *clipboard*, the picture will be available also for other programs. There, you can import it via menu **Edit** → **Insert**.

Image Title

In this input field, a header is preset when calling up the dialog box. It can be modified here.

Image Size

This dialog section defines the scale of the image on the paper.

As screen view arranges the window on the sheet according to the displayed size on the monitor. Hence, the image on the page will then be wider than high. By means of the option *Window filling*, the entire sheet will be used instead.

If the same size of the image as on the monitor is desired, select the option *As screen view*. With this, zoomed areas or special displays can be printed. With the option *Window filling*, the complete section will be shown on the paper, however. The section is then displayed in the defined *Vertical size of the image* (see below).

The third option *To scale* prints the image to a definable scale.

Page Settings

In this dialog section, the size of the image on the sheet can be defined. These settings are not accessible for short form prints, however.

If the check box *Use whole page* has been activated, a page-filling image will be printed.

Unless the entire vertical size is to be used for the print, the *Vertical size of the image* can be defined as percentage of the page.



Dlubal Engineering Software
 Am Zellweg 2, D-93464 Tiefenbach
 Phone: +49-(0)9673-1775 - Fax: +49-(0)9673-1770

Page: 8

Project: 2008

Position: Effective Widths

Date: 10/23/2008

NORMAL STRESSES

LC 1
 Sigma-x (x: 0.0 mm)

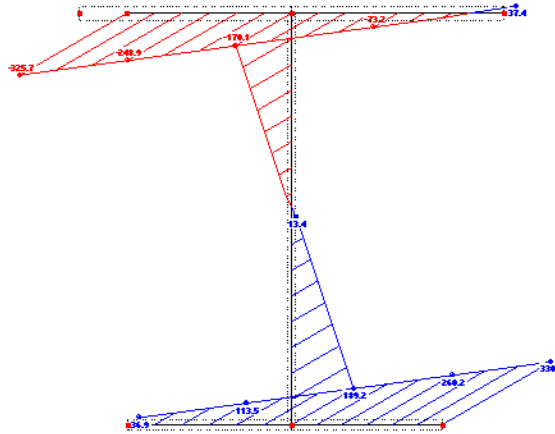

INPUT DATA

NODES [mm]				ELEMENTS [mm]			
No.	x	y	z	Nobeg	End	t	Mat length
1	-155.0	-150.5	-155.9	1	1	2	10.0
2	0.0	-150.5	-110.0	2	3	2	155.0
3	155.0	-150.5	-125.1	3	5	4	8.0
4	-120.0	150.0	-115.2	4	5	6	8.0
5	0.0	150.0	4.8	5	2	6	8.0
6	110.0	150.0	114.8	6	2	6	300.5

MATERIAL DATA [N/mm ²] [N/mm ²] [kN/m ³]			
No. description	E	G	gamma
1 Steel S 235	2.10E+05	8.10E+04	7.85E+01

LIMITING STRESSES [N/mm ²]			
No. Description	limit _x	limit _y	limit _z
1 Steel S 235	216.2	126.0	216.2

FORCES AND MOMENTS [kN] [kNm] [kNm ²]			
No. x	N	V _y	V _z
1 LC 1:	0.0	-50.00	40.00

SECTION PROPERTIES

A	66.89	cm ²	I, St.Ven.	16.13	cm ⁴
A _y	38.35	cm ²	I _{xx}	0.00	cm ⁴
A _z	16.58	cm ²	I _{yy}	8677.93	cm ⁴
A _y	38.35	cm ²	yM _D	0.31	cm
A _z	16.58	cm ²	zM _D	-7.64	cm
y _S D	-0.14	cm	yM _D	0.46	cm
z _S D	-2.84	cm	zM _D	-4.80	cm
I _y	11866.40	cm ⁴	I _{xy}	63050.00	cm ⁶
I _z	3297.58	cm ⁴	I _{yz}	552639.00	cm ⁶
I _y '	-164.15	cm ⁴	I _{xy}	-0.06	cm ⁶
I _z '	1.1	cm ⁴	W _{yy} max	642.61	cm ³
I _{yz}	11866.40	cm ⁴	W _{yy} min	-912.46	cm ³
I _{xy}	3294.43	cm ⁴	W _{yz} max	213.78	cm ³
I _{yz}	15160.90	cm ⁴	W _{yz} min	-211.14	cm ³
I _{xy}	16721.40	cm ⁴	W _{yy} max	650.32	cm ³
I _{yz}	13.32	cm	W _{yy} min	-933.54	cm ³
I _{xy}	7.02	cm	W _{yz} max	210.88	cm ³
I _{yz}	1.57	cm	W _{yz} min	-214.66	cm ³
I _{xy}	13.32	cm	W _{xy} M _{max}	2144.06	cm ⁴
I _{yz}	7.02	cm	W _{xy} M _{min}	-2101.27	cm ⁴
I _{xy}	16.06	cm	ry,Kindem	3.72	cm
I _{yz}	15.81	cm	rz,Kindem	-0.09	cm
I _{xy}	6.75	cm	W _M	0.003355	1/cm
I _{yz}	62.51	kg/m			
I _{xy}	168.70	cm			
I _{yz}	16.13	cm ⁴			

SHAPE-THIN 7.14.360

www.dlubal.com

Figure 9.31: Graphical short form printout

9.2.2 Print Quality

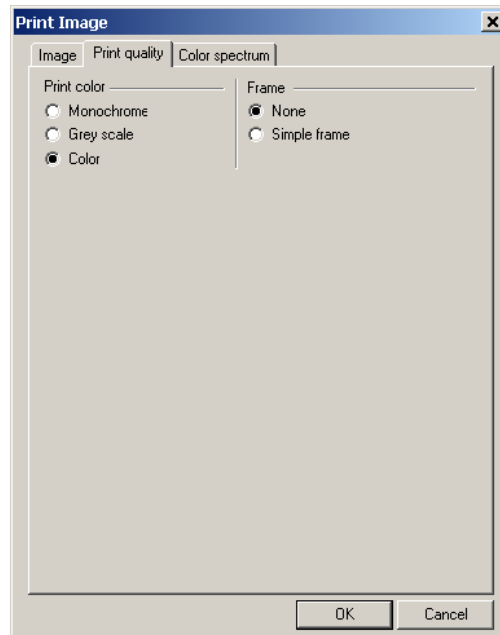

Figure 9.32: Dialog box *Print Image*, *Print quality* tab

Print Color

If the printing is to be directed to a black and white printer, the image can be printed *Monochrome* to improve the readability.



The conversion of the colored isosurfaces into gray scales is always managed by the printer and can therefore not be controlled in SHAPE.

Frame

A frame can be optionally printed around the image.

9.2.3 Color Spectrum

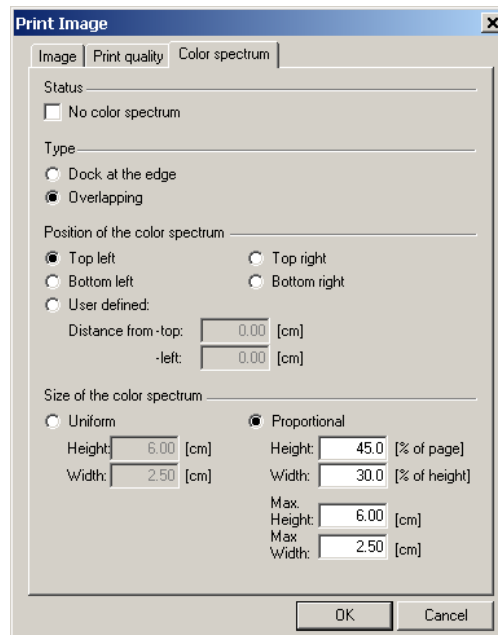

Figure 9.33: Dialog box *Print Image*, *Color spectrum* tab

This tab is presented additionally when the results are shown in multicolor display (cf chapter 8.2, page 139).

By default, the color scale of the control panel is printed, too. If this is not intended, the check box *No Color Spectrum* is to be activated.

If *Overlapping* has been selected for the position of the color spectrum, it will be placed inside the area of the sectional image. *Dock at the edge* reserves some part of the graphic window for the color spectrum.

Furthermore, it is possible to define the *Position of the color spectrum* in detail: It can be located in one of the four corners or arranged at a user-defined *Distance*.

The *Size of the color spectrum* can be specified in *Absolute* dimensions or *Proportional* to the picture size.

10. Tools

This chapter presents the different functions for the graphical and tabular input. They include the editing options for selected objects, the CAD functions to construct new sectional objects and the table operations. At the end of this chapter, a brief listing of the sectional generators is included.

10.1 Edit Objects

Objects that have been selected in the graphics can be modified by means of the graphical editing functions. The selected objects can be

- moved,
- copied,
- rotated,
- mirrored,
- divided or
- split up by an opening.

CAD tools, by contrast, require no previous selection. They facilitate the construction of new objects.

10.1.1 Graphic Selection

By selecting objects, specific elements are chosen to be manipulated. Those objects can be e.g. nodes, elements and point elements or auxiliary elements such as comments.

Objects can be selected by a mouse click and are then highlighted in the selection color (e.g. yellow or red). Only the currently highlighted object remains selected. If several objects are to be selected successively, use the [Ctrl] key when clicking on each object.

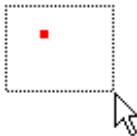

With the window selection, many objects can be selected in a single step. Draw a window around several objects to select them simultaneously. If the window is drawn from left to right, then all objects will be selected which are thoroughly located within this area. If this window is drawn inversely from right to left, also objects will be selected that are only partially within this area.

If the selection via a rectangular window turns out to be a bit difficult, the function *Selection with Rhomboid* can be used instead which is started via menu

Edit → Select → Select with Rhomboid.

10.1.2 Special Selection

Objects can be selected according to specific criteria. With this tool, objects can also be added to or removed from an existing selection.



The special selection can be started via menu

Edit → Select → Special.

The following dialog box appears.

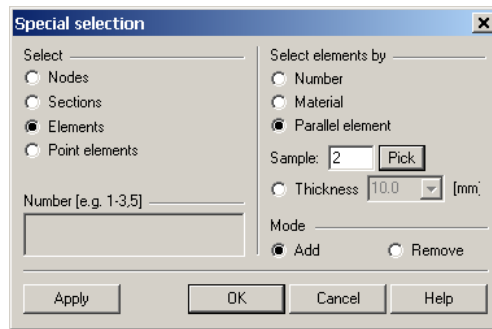

Figure 10.1: Dialog box *Special selection*

Certain types of objects are listed in dialog section *Select*. In the right part of this dialog box, a selection criterion can be defined and specified in detail with additional data.

The dialog section *Mode* controls whether the objects are to be added to or removed from the current selection.



When selecting parallel elements, it is possible to [Pick] the template element graphically.

10.1.3 Move and Copy

Selected objects can be moved or copied via menu



Edit → **Move/Copy**

or the corresponding button in the toolbar.

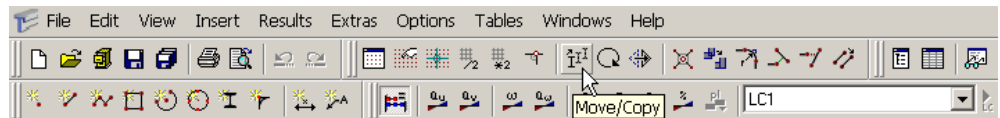

Figure 10.2: Button *Move and/or Copy*

The following dialog box appears.

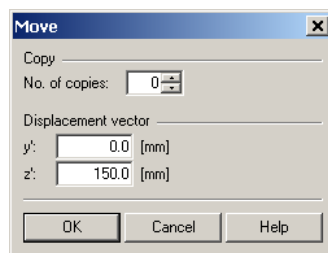

Figure 10.3: Dialog box *Move - Copy*

If the *Number of copies* is zero, the selected objects will be moved. Otherwise, the defined number of copies will be created.

The *Displacement vector* can be determined numerically by the coordinates *y'* and *z'* or defined graphically by picking two nodes or grid points.



Copies can also be quickly created via Drag & Drop of selected objects, while the [Ctrl] key is kept pressed.

10.1.4 Rotate



Selected objects can be rotated about a specific point of rotation via menu

Edit → Rotate

or the corresponding button in the toolbar.

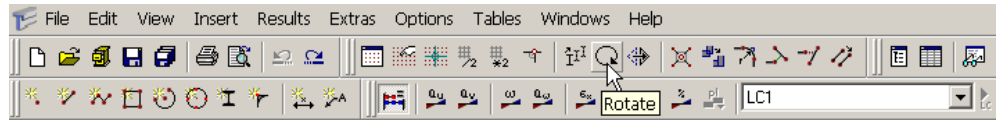

Figure 10.4: Button *Rotate*

The following dialog box will be displayed.

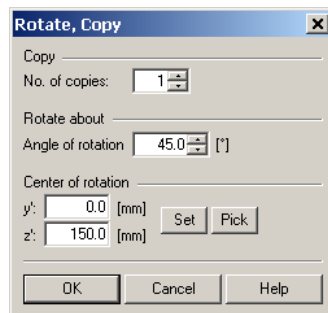

Figure 10.5: Dialog box *Rotate, Copy*

If the *Number of copies* is zero, the selected objects will be rotated. Otherwise, the defined number of copies will be created.

The *Angle of rotation* is related to a clockwise coordinate system. It can be defined either manually or also graphically after having selected the *Center of rotation* by a mouse click.

10.1.5 Mirror



Selected objects can be mirrored via menu

Edit → Mirror

or the corresponding button in the toolbar.

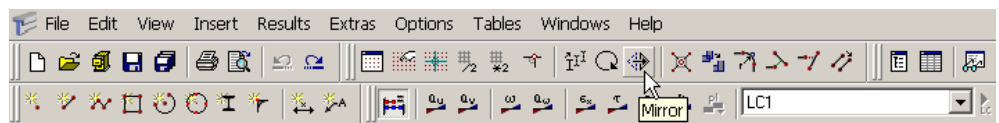

Figure 10.6: Button *Mirror*

The following dialog box appears.

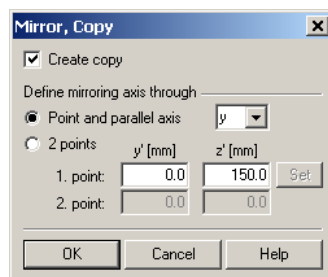

Figure 10.7: Dialog box *Mirror - Copy*

If the original objects are to be maintained, activate the check box *Create Copy*.

The *mirroring axis* can be defined in two ways:

- If it is parallel to one of the global axes *y* or *z*, it can be selected from the list after having activated the first selection field. Additionally, one *Point* is to be specified that lies on this axis.
- If the mirroring axis is oriented arbitrarily, the second selection field *2 Points* has to be activated. The axis can then be defined by entering the coordinates of two points or by picking them in the graphics.

10.1.6 Divide

An element can be divided by right-mouse clicking it and choosing *Divide elements* in the context menu. Alternatively, one of the two options of menu

Edit → Divide Elements

can be used.

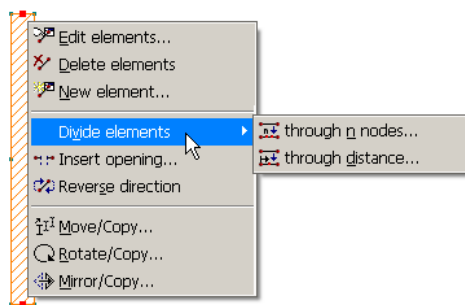

Figure 10.8: Context menu *Divide elements*

There are two options to divide the selected element.

n Nodes

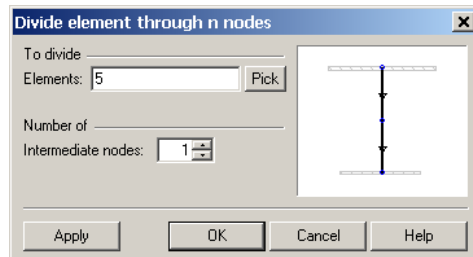

Figure 10.9: Dialog box *Divide element through n nodes*

This function divides the selected element equally into several new elements. The preferred way of division can be specified in the input field *Number of intermediate nodes*.

Distance

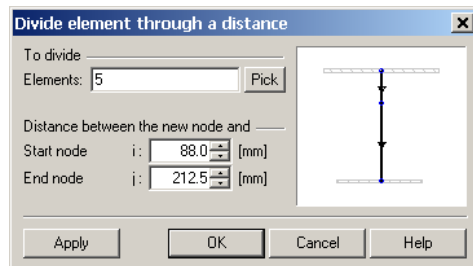

Figure 10.10: Dialog box *Divide element through a distance*

This function creates a division node at a definable location of the selected element. The defined *Distance between the new node* can refer to the *Start* or *End* node of the element. The right-hand interactive image in this dialog box gives information on the element direction which is essential when defining the distance.

10.1.7 Insert Opening

With this function, an opening is created within an element. An example of this feature can be found in the introductory example in chapter 3 of this manual on page 20.

To apply this function, right-mouse click the element and then choose *Insert opening* in the context menu. Alternatively, you can use the menu

Edit → **Insert opening in element**.

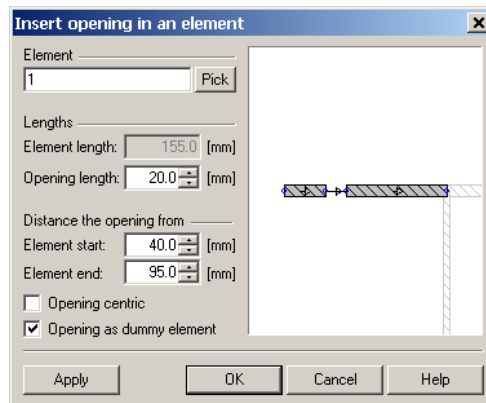

Figure 10.11: Dialog box *Insert Opening in Element*

If the element has not been selected before the dialog box was called up, you can choose it in the graphics via the [Pick] button.

Beneath the *Element length* which is indicated for information, the *Opening length* can be entered. The defined *Distance from the opening* can refer to the *start* or *end* node of the element. The right-hand interactive image in this dialog box gives information on the element direction which is essential when defining the distance.

If there is a *centric* opening, its input can be facilitated via the respective check box. The two input fields of the distances then become inaccessible.

By default, the opening is inserted as *dummy element*, which means that a zero element is created between the two element ends so that the shear flow is not interrupted. If no shear transfer is desired, however, the last check box has to be deactivated.

10.1.8 Create and Reduce Section

Create Section from Sectional Parts

It may be useful to classify certain areas of the section as a sectional unit, e.g. for composite sections. These will then be added to the list of sections in table 1.3 *Sections*.

Select the relevant elements and point elements with the mouse and the pressed [Shift] key or by pulling up a window over the relevant objects. Then call up menu

Edit → **Additional tools** → **Create section from selected elements**.

This function is also included in the element context menu which can be called up by right-mouse clicking one of the selected elements (cf Figure 10.8, page 170).

The following dialog box appears.

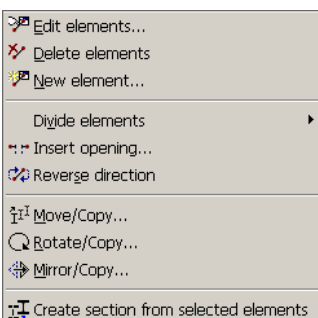

Element context menu

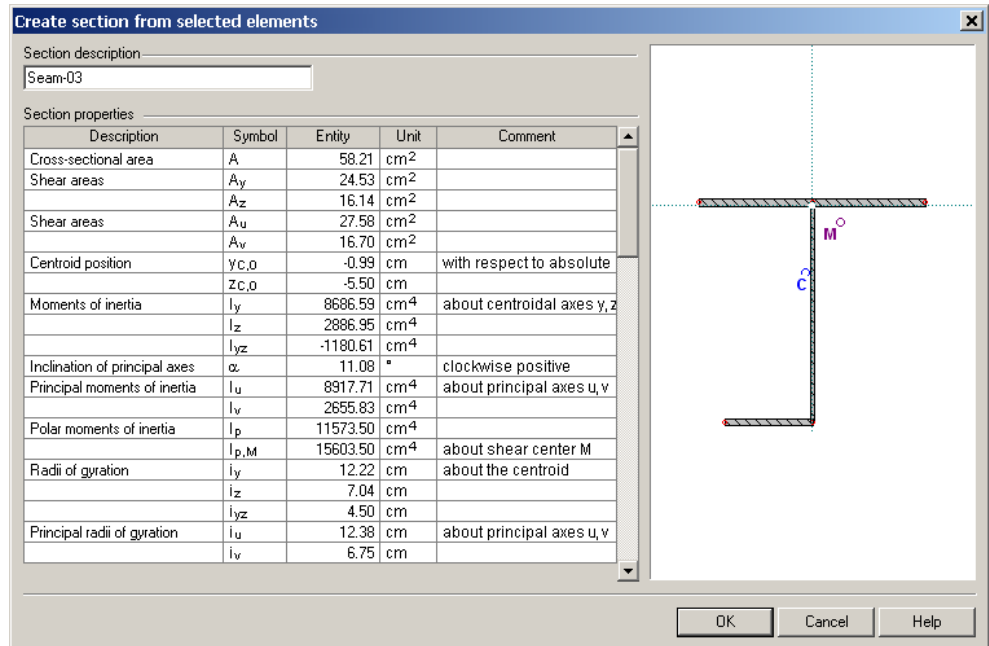

Figure 10.12: Dialog box *Create section from selected elements*

Enter the *Section description* to allocate a specific name for this user-defined sectional part. The selected elements are shown in the right-hand image which also displays the centroid C and the shear center M of this new section.

In this dialog box, all *Section properties* of the selected set of elements are listed in detail. The layout of this list corresponds to table 2.1 *Section properties*. If different materials are used in this section, the ideal section properties are presented.

After [OK], the new section will be added to the list in table 1.3 *Section*.

Reduce Section into Components

A section (cf chapter 5.3) has to be dismantled into its elements and point elements before its components can be edited, e.g. cutting off or adjusting elements.

To reduce a section into its components, click this section to select it and call up menu **Extras** → **Reduce section into elements**.

Alternatively, this function can be activated by right-mouse clicking the section. Then choose the context menu option *Reduce section into elements*.

The following message appears after the section has been dismantled.



Figure 10.13: Message when reducing section into its components

10.1.9 Scale Elements

The size of selected elements and point elements can be modified via menu **Edit** → **Additional tools** → **Scale**.

The following dialog box opens.

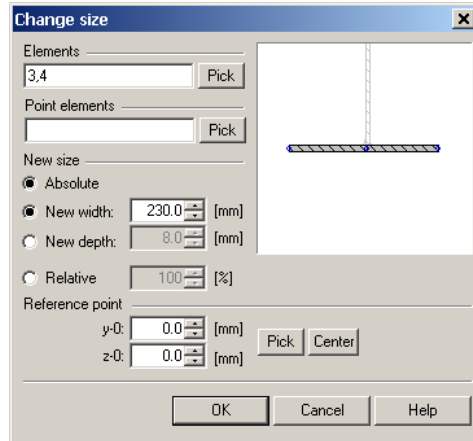

Figure 10.14: Dialog box *Change size*

Pick

If no *Elements* or *Point elements* have been selected yet, their numbers can be defined in the two input fields. Alternatively, you can [Pick] them in the graphics.

The *New size* of the selected elements can be defined by entering the *Absolute* values of the *New width* (size in direction y_0) or *New depth* (size in direction z_0). Alternatively, the scaling can be *Relative* via the percentaged factor.

Pick Center

The *Reference point* which is to represent the origin for the scaling can be defined by its coordinates y_0 and z_0 . You can also [Pick] it in the graphics. If the [Center] is selected, the scaling will be related to the centroid of all selected elements and point elements.

10.2 CAD Tools

The CAD tools facilitate the graphical input of objects, e.g. by means of grid options and features to create or combine elements.

10.2.1 Grid

Grid points are useful to define objects in the graphics. When setting elements, the cursor snaps on the grid points. The grid is switched on or off with the button as seen to the left.



The features of the grid are defined in the *Grid Settings* dialog box. It is called up via menu

Options → Grid

or the corresponding button in the toolbar.



Figure 10.15: Button *Set grid*

The following dialog box is called up.

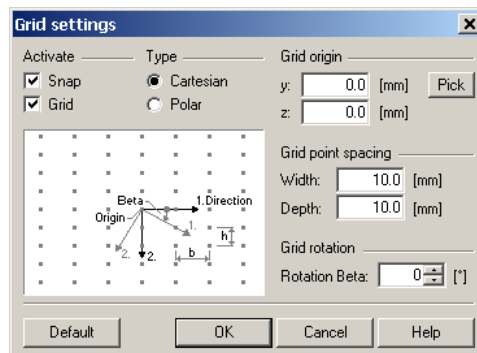

Figure 10.16: Dialog box *Grid settings*

Activate

The check box *Grid* switches the grid on or off. The snap function can be switched on or off via the check box *Snap*. The snap function also acts on the grid points of an invisible grid.

Type

The grid points can be arranged with reference to the Cartesian or polar coordinate system (cf chapter 5.1, page 66). This choice also controls the parameters of the grid point spacing.

Grid Origin

The origin of the grid is defined by its coordinates y_0 and z_0 . It can also be determined graphically with the [Pick] button.

Pick



Without the necessity to call up the *Grid Settings* dialog box, the button [Select grid origin] in the toolbar allows for a quick choice of the origin.

Grid Point Spacing

In the case of a Cartesian grid, the spacing of the grid points can be separately defined for the *Width* (b in the dialog box image) and the *Depth* (h in the image).

For the polar grid, the radial spacing R of the concentric circles can be determined. The angle α defines the grid point spacing on the circles.

Grid Rotation

Optionally, both the Cartesian and the polar grid can be rotated by the angle β .

10.2.2 Smoothen Corners

The section properties and stresses may not be accurately calculated where elements meet at an angle on a common node. To adjust those elements, activate menu

Edit → **Smoothen corners**

or click the corresponding button in the toolbar.

The mouse pointer then features an additional angle. Click into the intersecting area of both elements that has to be adjusted.

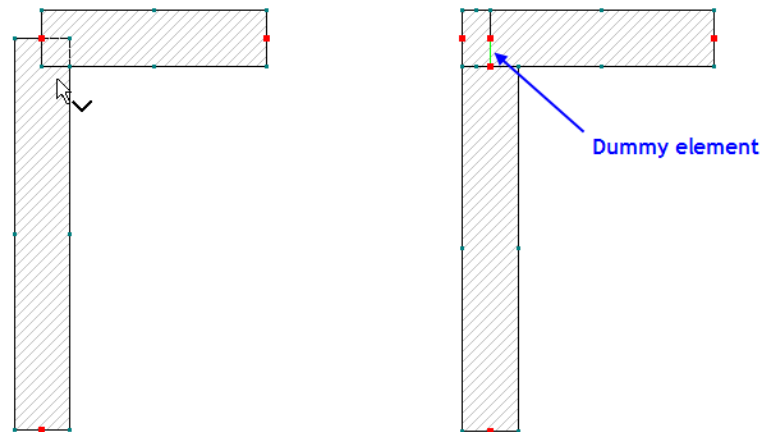

Figure 10.17: Smoothen corners – before and after

As a result, the selected element side is shortened, and the adjacent side is lengthened by adding a new element. Additionally, a dummy element is created so that the shear flow is not interrupted.

10.2.3 Round off Corners

Elements with a shared node can be connected by an arc element. Even non-connecting elements can be connected with this function.

To realistically model corners with a rounding radius, open menu

Edit → **Round off corners**

or click the corresponding button in the toolbar. The following dialog box opens.

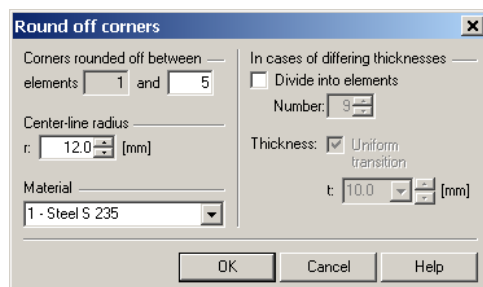

Figure 10.18: Dialog box *Round off Corners*

In this dialog box, it is recommended to determine the *Center line radius r* of the arc element first. The *Material* can be selected from the list.

If both elements do not have the same thickness, the arc can be divided into several elements with a continuous adjustment of the thicknesses. The *Number* of the divisions defines how many elements are to be created. If a *Uniform transition* with interpolated thicknesses is inappropriate, deactivate the check box and then define the *Thickness t* for all elements.

Now click the two elements successively that are to be connected by an arc. The element numbers of the current mouse pointer location will be shown in the two input fields
Corners rounded off between elements.

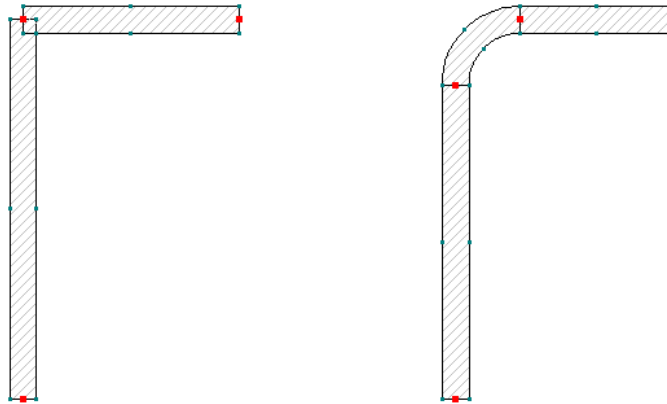

Figure 10.19: Round corners – before and after

10.2.4 Connect Elements

This function connects elements whose center lines cross without a common node. To adjust those elements, activate menu

Edit → Connect elements

or click the corresponding button in the toolbar.

The mouse pointer then features an additional rectangle. Pull up a window over the intersection area to call up the following dialog box.

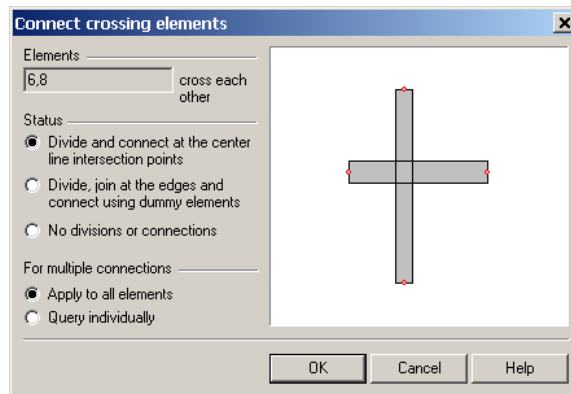

Figure 10.20: Dialog box *Connect crossing elements*

There are three options how to treat the selected elements:

- SHAPE can divide the elements and create new nodes at the intersection points of the *center lines*.
- The elements can be divided and joined at the element edges instead at the centers. *Dummy elements* are then used to connect the element edges to the center lines.
- It is also possible to apply *no division or connections*.

If several elements are to be connected at the same time, the selected option can be applied either to all elements or individually with extra queries for each action.



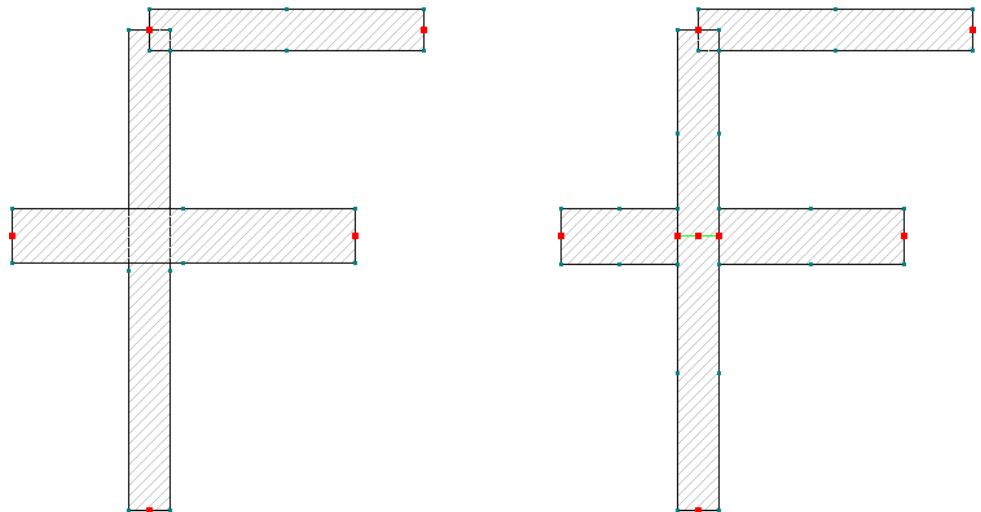

Figure 10.21: Connect elements with dummy elements – before and after

10.2.5 Connect Node and Element

Contrary to connecting elements, this function does not require a common intersection point to connect elements. A start or end node of an element is connected to another element by a dummy element. Thus, a rigid connection can be created between two elements that neither meet nor intersect.

If the connection is to be applied to the prolongation of the element, the function *Extend Element* is recommended (see next chapter).



The function is called up via menu

Edit → **Connect node and element**

or the corresponding button in the toolbar. The following dialog box appears.

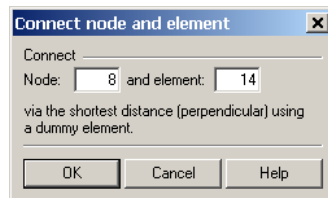

Figure 10.22: Dialog box *Connect node and element*

Define the *Node* number of the element that is to be connected or click the node in the graphics. Then define the number of the *element* that this node is to be joined with, which can be also done graphically. A dummy element will be created, using the shortest distance.

10.2.6 Extend Element to Element

This function adjusts the length of an element in general or extends it to another element.



It can be called up via menu

Edit → **Extend element to element**

or the corresponding button in the toolbar.

The following dialog box appears.

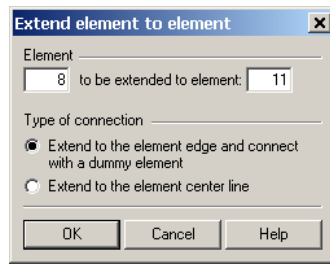

Figure 10.23: Dialog box *Extend element to element*

There are two options how the connection is to be realized:

- The first element can be extended to the element edge of the second element and then be connected by a *dummy element* to its center line.
- SHAPE can extend the element to the center line of the target element.

Define the numbers of both elements or simply click on them in the graphics.

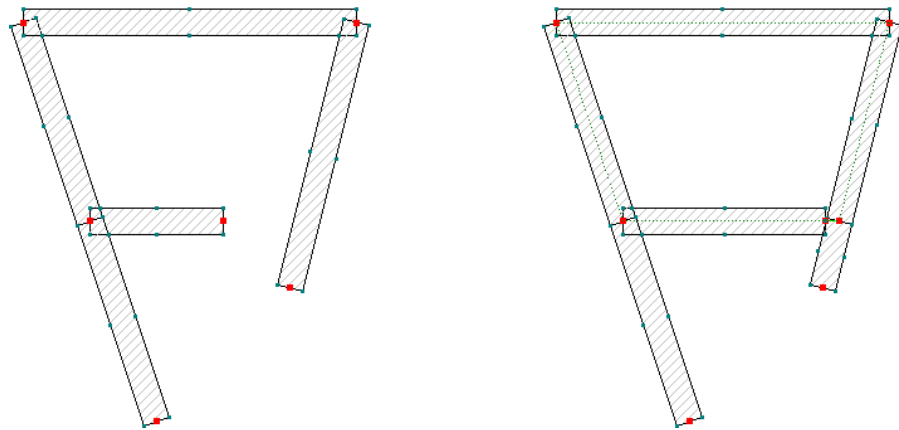

Figure 10.24: Extend element to element and connect with dummy element – before and after

10.2.7 Change Element Length

This function is useful to adjust the length of an element in general. It is called up via menu

Edit → **Change element length**.

The following dialog box appears.

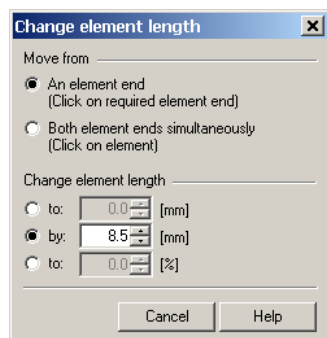

Figure 10.25: Dialog box *Change element length*

The modification can applied to *One element end* or at *Both element ends simultaneously*.

Before selecting the respective element resp. element end by a mouse click in the graphics, the *Change of element length* has to be defined. There are three selection fields available which allow for the specification of the absolute or relative new length of the element.

10.2.8 Set Parallel Elements

With this function, parallel elements can be set. It is called up via menu
Edit → Set parallel elements.

The following dialog box is opened.

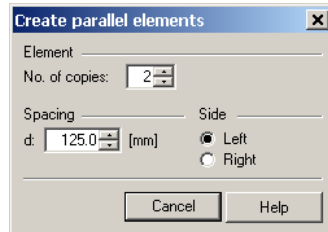

Figure 10.26: Dialog box *Create Parallel Elements*

Define the *Number of copies* and the *Spacing d* which represents the distances between the parallel elements. They are related to the center lines of the elements.

The *Side* refers to the element orientation, i.e. the order of the start and end nodes of the element that is to be copied. The parallel elements are then created by a mouse click on the specific element.



Parallel elements can also be quickly created via Drag & Drop of selected elements, while the [Ctrl] key is kept pressed.

10.2.9 Create Rectangular Hollow Section



With this tool, user-definable rectangular hollow sections with or without rounded corners can be generated. The dialog box which allows for the parametrized input is accessible via menu

Insert → Sections → Graphics → RHS

or the corresponding button in the toolbar. The following dialog box appears.

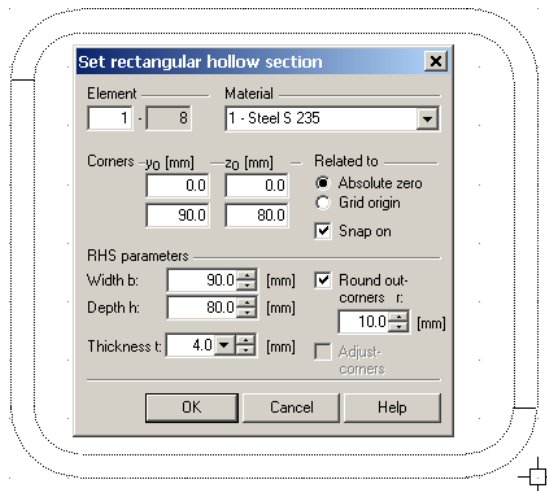

Figure 10.27: Dialog *Set rectangular hollow section*

The numbers of the generated elements are shown in the *Element* section of this dialog box where it is also possible to control the number of the first element. The *Material* can be selected from the list.

Set the *Corners* by entering the coordinates of the two nodes that represent the diagonal of the hollow section. These can be related to the *Absolute zero* point (y_0/z_0) or to the user-defined *Grid origin* (y/z). The nodes can also be set graphically. After having chosen the first corner, the dotted outline of the new section can be moved with the mouse pointer. The second corner is then anchored by another click. The *Snap on* option makes positioning on a grid point easier.

If the corner nodes are not defined graphically, the *RHS parameters* can be set by entering the *Width b* and *Depth h* of the section which refer to the outer contour of the section. The *Thickness t* has to be defined manually in any case, however.

If the section is to be created with *Rounded corners*, the *Radius r* of the arc can be defined. In this case, it is not possible to *Adjust corners* as this option is applicable only for right-angled corners for which smoothed corners can be created (cf chapter 10.2.2, page 175).

10.2.10 Create Circular Hollow Section



With this tool, user-definable circular hollow sections can be generated. The dialog box which allows for the parametrized input of pipes is accessible via menu

Insert → Sections → Graphics → CHS

or the corresponding button in the toolbar. The following dialog box is opened.

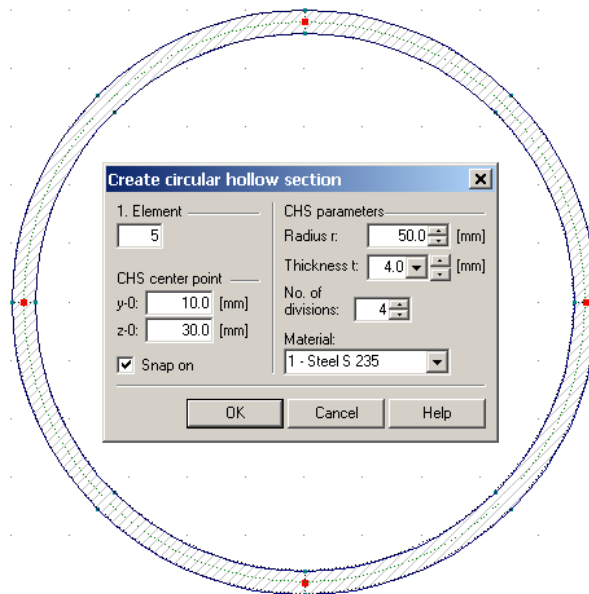

Figure 10.28: Dialog box *Create circular hollow section*

In this dialog box, it is possible to modify the number of the first generated *Element* and to select the adequate *Material* from the list.

Determine the *Center point* by entering its coordinates y_0 and z_0 or by clicking on this point in the graphics. The *Snap on* option facilitates the graphical selection of a grid point.

The *Radius r* refers to the outer diameter of the circular section. If it is selected graphically with the mouse by pulling up a circle, the projected pipe is interactively drawn by dotted lines. The *Number of divisions* controls the number of arc elements that are to be created.

When the *Thickness t* has been entered, the CHS can be set with [OK] or by a mouse click that defines the radius.

10.3 Table Functions

10.3.1 Editing Functions



Editing functions facilitate the tabular input. Contrary to the block operations (cf chapter 10.3.2), it is not necessary to previously select several cells. Editing functions only have an effect on the current cell in which the cursor is positioned.

Call up the Editing Functions

The cursor must have been placed in the table. All editing functions are available via menu **Tables → Edit**.

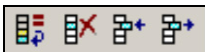

Some editing functions are also accessible in the toolbar of the table.



Figure 10.29: Buttons for some *Editing Functions* in the toolbar of the tables

Alternatively, these functions can be called up via the table context menu (cf Figure 10.30, page 182).

Functions and Commands



Function	Effect
Cut [Ctrl+X]	Removes the contents of the cell and saves it to the clipboard.
Copy [Ctrl+C]	Copies the contents of the cell to the clipboard.
Paste [Ctrl+V]	Inserts the contents of the clipboard. If the clipboard contents are bigger than a cell, the cells of the following columns and lines will be overwritten. Before this, a warning appears.
Copy Row [Ctrl+2]	Overwrites the following line with the contents of the current line.
Empty Row [Ctrl+Y] 	Deletes the contents of the line without deleting the line itself.
Insert Row [Ctrl+I] 	Inserts a new, empty line and moves all subsequent lines downwards.
Delete Row [Ctrl+R] 	Deletes the entire line and moves all subsequent rows upwards.
Find [Ctrl+F]	Searches a number or string within the table.
Replace [Ctrl+H]	Searches a number or string within the table and replaces it.
Pick [F7]	Opens a list within a cell.

Table 10.1: Editing functions

Examples

Copy Row

The function is called up via the context menu of row 6.

5	Cartesian	0	0.0	150.0		
6	Cartesian	0	110.0	150.0		
7	Cartesian	0	120.0			
8						
9						
10						
11						
12						
13						
14						
15						
16						
17						
18						
19						
20						

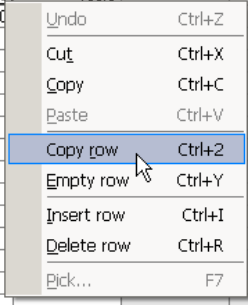

Figure 10.30: Copy row 6 via the context menu

Row 7 will be overwritten.

5	Cartesian	0	0.0	150.0		
6	Cartesian	0	110.0	150.0		
7	Cartesian	0	110.0	150.0		

Figure 10.31: Result

Insert Row

The function is called up via the context menu of row 3.

1	Cartesian	0	-155.0	-150.5		
2	Cartesian	0	0.0	-150.5		
3	Cartesian	0	155.0	-150.5		
4	Cartesian	0	-120.0			
5	Cartesian	0	0.0			
6	Cartesian	0	110.0			
7						
8						
9						
10						
11						
12						
13						
14						
15						
16						
17						

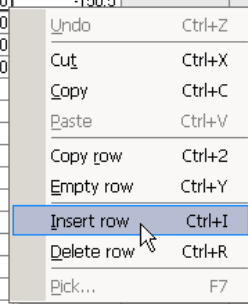

Figure 10.32: Inserting row via context menu

A new, empty row will be inserted. All subsequent rows are moved downwards.

1	Cartesian	0	-155.0	-150.5		
2	Cartesian	0	0.0	-150.5		
3	Cartesian	0				
4	Cartesian	0	155.0	-150.5		
5	Cartesian	0	-120.0	150.0		
6	Cartesian	0	0.0	150.0		
7	Cartesian	0	110.0	150.0		

Figure 10.33: Result

The *Value* which has to be added can be entered in a dialog box.

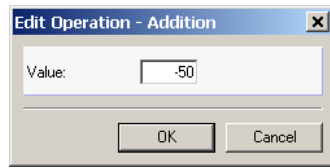

Figure 10.38: Dialog box *Edit Operation - Addition*

-200.5
-200.5
-200.5

Figure 10.39: Result

All numerical values within this selection have been reduced by 50. Empty cells are still empty.

Generate

With this function, it is possible to quickly fill cells. The numerical values are linearly interpolated from the start value of the top cell (e.g. 5.00) and the end value of the bottom cell (e.g. 350.00).

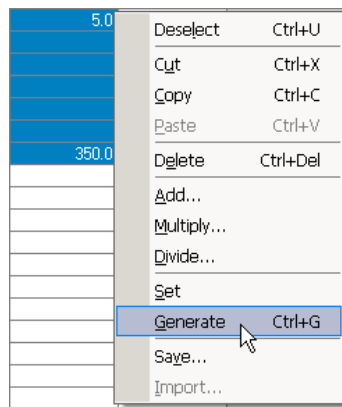

Figure 10.40: *Block* context menu

All selected cells will be filled with the intermediate values.

5.0
62.5
120.0
177.5
235.0
292.5
350.0

Figure 10.41: Result

10.3.3 Viewing Functions

By means of the viewing functions, the number of cells that are displayed can be reduced. Thus, the clarity within the tables is improved.

Call up the Viewing Functions

All viewing functions are available via menu

Tables → View.

Some viewing functions are also accessible in the toolbar of the table.



Figure 10.42: Buttons for *Viewing Functions* in the toolbar of the tables

Functions



Function	Effect
Used Rows Only 	Hides all empty rows.
Marked Rows Only 	Shows only selected rows.
Selected Objects Only 	Shows only objects that are selected in the graphics.
Title Bar	Switches the title bar on and off.
Toolbar	Switches the toolbar on and off.
Column Header	Switches the column bar (A, B, C, ...) on and off.
Status Bar	Switches the status bar of the table on and off.

Table 10.3: Viewing Functions

Example: Used Rows Only

A table contains several empty rows, which might be distracting.

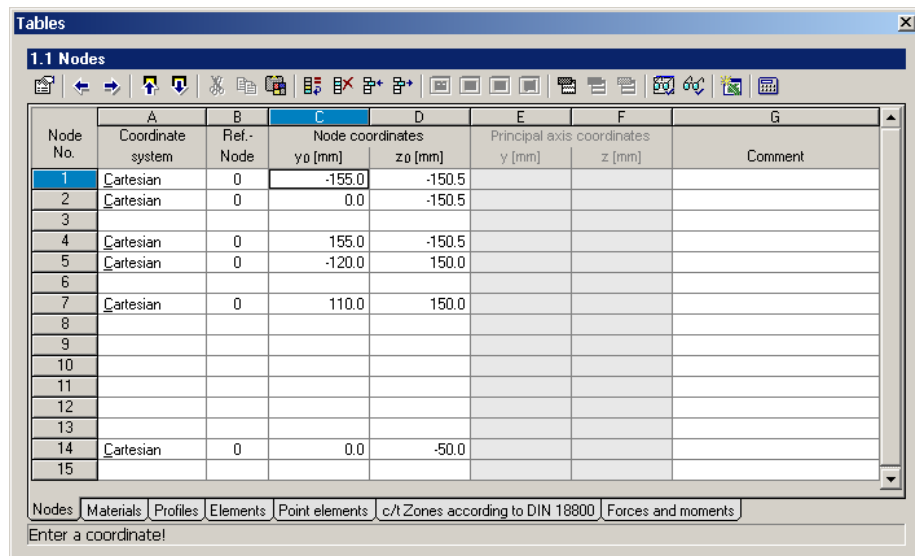

Figure 10.43: Table with empty rows

The function *Used Rows Only* hides all empty rows.

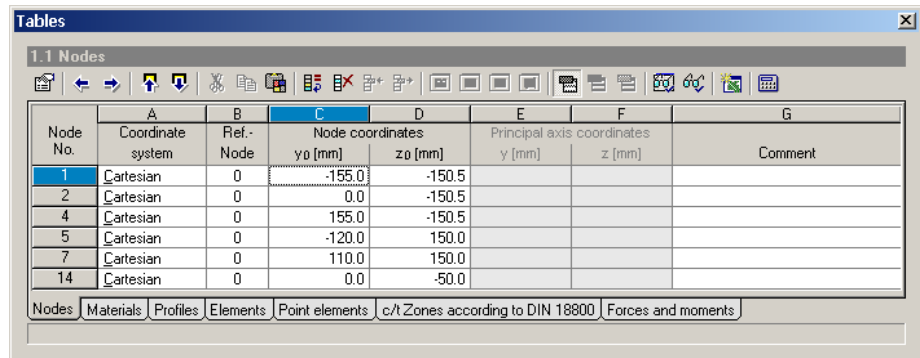

Figure 10.44: Table without empty rows

10.3.4 Table Settings

The fonts and colors of the tables can be adjusted. Furthermore, the selection of the graphics can be synchronized with the tabular selection.

Call up the Table Settings

All table settings are available via menu

Tables → Settings.

Some settings are also accessible in the toolbar of the table.



Figure 10.45: Buttons *Synchronization of the Selection*

Functions



Function	Effect
Colors	Calls up the <i>Colors</i> dialog box in which the color settings can be adjusted for all elements of the table individually
Fonts	Calls up the <i>Fonts</i> dialog box in which the font, font style and size can be changed for the tables
Select Object in Graphics 	If this option is active (default), the objects of the current cell(s) are selected in the graphics.
Show Selected Objects in Tables 	If this option is active (default), the selected objects of the graphics are highlighted in the table, too.

Table 10.4: Table Settings

10.3.5 Filter Functions

The filter options in the tables of the section characteristics and stresses allow for a user-definable layout of those results tables.

The result filters are accessible via menu

Tables → View → Columns filter

or the extra button in the toolbar of the table.

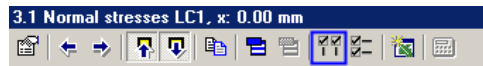

Figure 10.46: Button *Filter results* in the toolbar table 3.1 *Normal stresses*

The following dialog box opens in which the results that are to be displayed can be selected.

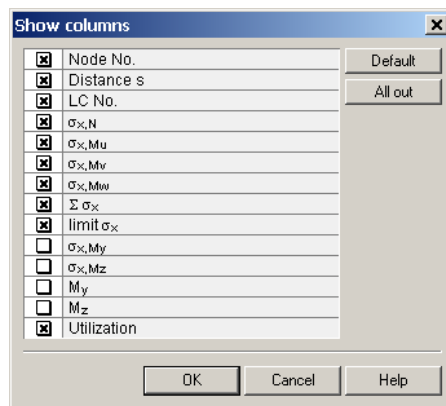

Figure 10.47: Dialog box *Show Columns*

10.3.6 Import and Export Tables

An Excel table can be imported directly into the current input table of SHAPE. MS Excel™ must have been started before these functions can be carried out. Vice versa, it is possible to export the current SHAPE table to Excel.

Call up the Import and Export Function

The function is started by clicking on the [Excel] button in the toolbar of the tables.

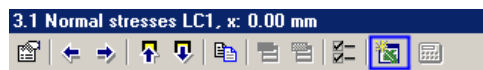

Figure 10.48: Button *Import/Export to MS Excel* in the table toolbar

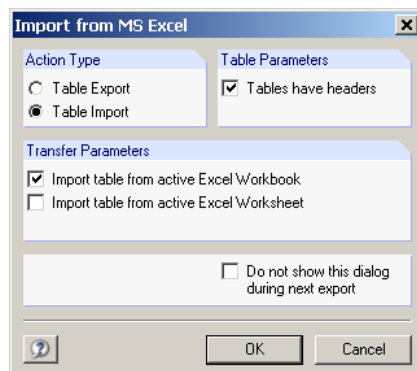

Figure 10.49: Dialog box *Import from MS Excel*



Figure 10.50: Dialog box *Export to MS Excel*

Depending on the *Action Type* settings of the dialog box, the import resp. the export options can be defined in detail.

Import Tables

Excel must have been opened before the import. In case of worksheets with headers, the check box *Table has Header* is to be activated. Then the header lines are ignored and only the selected list is imported in the SHAPE tables.

In section *Transfer Parameters*, the import of the active workbook or worksheet can be selected. When importing a complete workbook, the order and structure of the worksheets must completely correspond with the SHAPE tables.

The import is started with [OK].



If only parts of the worksheet are to be imported, the copying function is advisable: Mark the area in the Excel table and copy it to the clipboard with [Ctrl]+[C]. Then place the cursor in the adequate cell of the SHAPE table and insert the contents with [Ctrl]+[V].

Export Tables

Excel does not need to run in the background before exporting SHAPE tables. In the dialog section *Table Parameters*, the export with or without header can be defined. If the check box is active, the result in Excel will be the following:

	A	B	C	D	E	F
1		Description	Symbol	Value	Unit	Comment
2		Cross-sectional area	A	63,43	cm ²	
3		Shear areas	A _y	30,66	cm ²	
4			A _z	16,64	cm ²	
5			A _y	36,82	cm ²	
6			A _z	16,74	cm ²	
7		Centroid position	y' _{SO}	0,61	cm	with respect to absolute zero
8			z' _{SO}	-2,18	cm	
9		Moments of inertia	I _y	11318,90	cm ⁴	about centroidal axes y', z'
10			I _z	2615,70	cm ⁴	
11			I _{y_z}	-771,72	cm ⁴	
12		Inclination of principal axes	α	5,03	°	clockwise positive
13		Principal moments of inertia	I _y	11386,80	cm ⁴	about principal axes y, z in C
14			I _z	2547,80	cm ⁴	
15		Polar moments of inertia	I _p	13934,60	cm ⁴	
16			I _{pM}	14700,50	cm ⁴	about shear center M

Figure 10.51: Excel table with exported header

If the check box is inactive, then only the table contents are imported in Excel as shown in the following image.

	A	B	C	D	E	F
1		Cross-sectional area	A	63,43	cm ²	
2		Shear areas	A _y	30,66	cm ²	
3			A _z	16,64	cm ²	
4			A _y	36,82	cm ²	
5			A _z	16,74	cm ²	
6		Centroid position	y' _{SO}	0,61	cm	with respect to absolute zero
7			z' _{SO}	-2,18	cm	
8		Moments of inertia	I _y	11318,90	cm ⁴	about centroidal axes y', z'
9			I _z	2615,70	cm ⁴	
10			I _{y_z}	-771,72	cm ⁴	
11		Inclination of principal axes	α	5,03	°	clockwise positive
12		Principal moments of inertia	I _y	11386,80	cm ⁴	about principal axes y, z in C
13			I _z	2547,80	cm ⁴	

Figure 10.52: Excel table without header

The check box *Only Selected Rows* is available if a block was selected in the table. It controls whether only this block or the complete table is to be exported.

The *Transfer Parameters* control whether the active workbook is to be used. If this check box is deactivated, a new workbook will be created. The same applies to the option *Export table to active Excel Worksheet*. If the check box is activated, the current worksheet is used, with the option to overwrite it.

If *Rewrite Existing Worksheet in Excel* is enabled, a table with the same name as in SHAPE is searched for and then overwritten.

[OK] starts the export of the current SHAPE table.

10.4 General Functions

This chapter describes some program functions which are of general importance and which are accessible in many dialog boxes.

10.4.1 Display Objects

The display settings determine **which** graphical objects are shown. The viewing options that are described in the following chapter, however, control **how** the objects are displayed.

The dialog box to define the display parameters for the objects is called up via menu

View → Display

or the corresponding button in the toolbar. This option is also included in the context menu which can be activated by right-mouse clicking in the 'empty' work area.

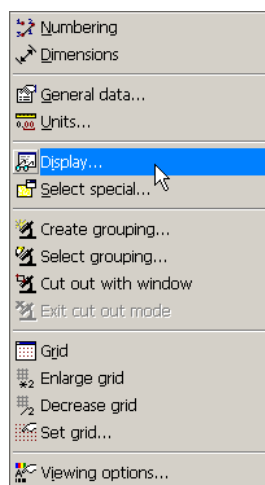

Figure 10.53: SHAPE context menu

The following dialog box appears.

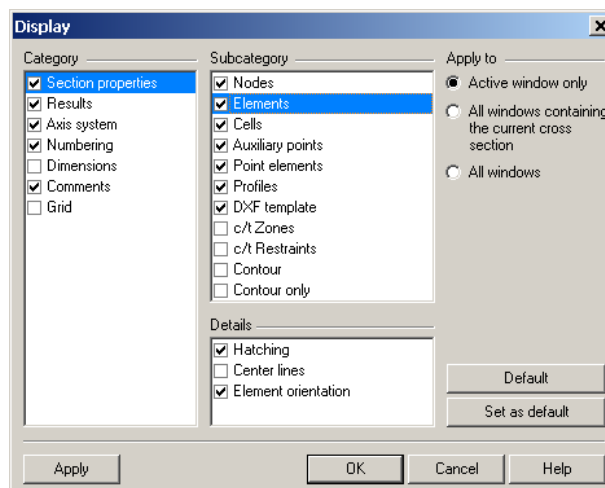

Figure 10.54: Dialog box *Display*, category *Section properties*

For every *Category*, many different items can be selected among the *Subcategories* that are to be displayed. The *Details* that can additionally be set depend on the selected item.

If several windows are being used in SHAPE, the reference of the modified settings can be specified in dialog section *Apply to*.

10.4.2 Viewing Options

The viewing options control **how** graphical objects are displayed. By contrast, the display settings that are described in the previous chapter determine **whether** an object is shown or hidden in the graphics.



The dialog box in which you can customize the viewing options is called up via menu

Options → Viewing options

or the general context menu which can be activated by right-mouse clicking in the 'empty' work area (cf Figure 10.53, page 191).

The following dialog box appears.

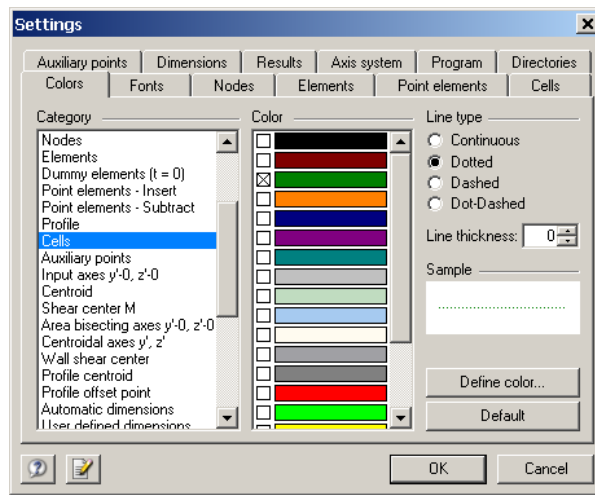

Figure 10.55: Dialog box *Settings*, *Colors* tab

This dialog box consists of several tabs which allow for a detailed allocation of colors, line types, fonts, sizes etc. of the various items. An interactive *Sample* is shown in each tab.

In general, the graphical object is selected from the *Category* list. Then its parameters can be defined for the display. The following figure illustrates all options for the elements.

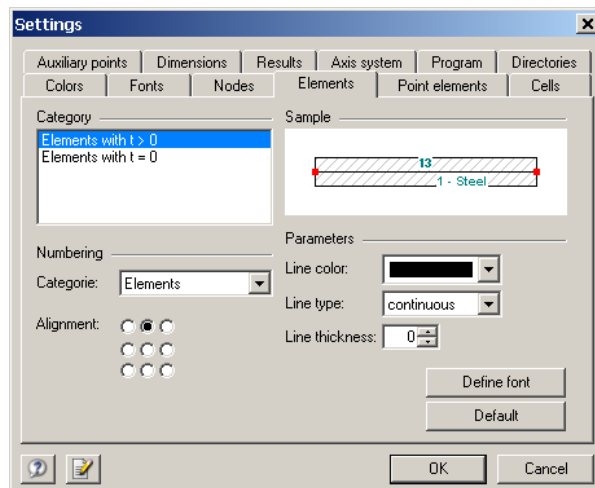
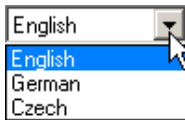

Figure 10.56: Dialog box *Settings*, *Elements* tab



The *Program* tab allows for program-specific settings. Among others, the language of the SHAPE user interface can be selected:

- English
- German
- Czech

It is possible to save user-defined viewing options via menu

Options → **Save as**.

The Windows dialog box *Save as* is called up where the location and the file name of the new configuration file (*.cfg) can be defined.

Vice versa, configuration files with user-defined settings can be imported via menu

Options → **Load**.

10.4.3 Units and Decimal Places

Units and decimal places are managed in a separate dialog box.



In the *General Data* dialog box, the units and decimal places can be directly accessed via the respective button. Alternatively, apply menu

Options → **Units**

to call up the following dialog box.

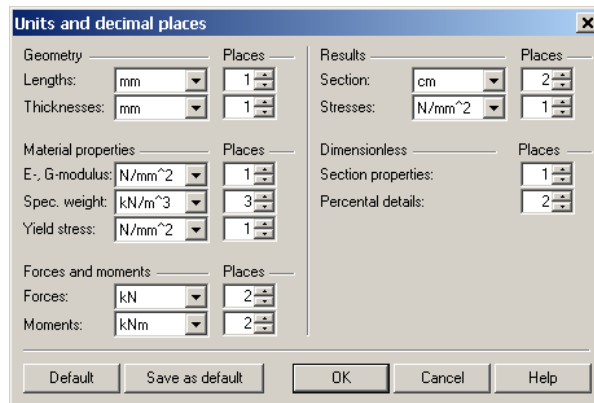
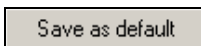

Figure 10.57: Dialog box *Units and Decimal Places*

The settings for the units and decimal places can be changed when working on a section. All numerical values are converted or adjusted.

All settings can be made in detail for the *Geometry* of the section, the *Material properties*, the *Forces and moments* and for the *Results*.



Via the [Save as default] button, the modified settings can be set as standard for new sections.

10.4.4 Dimensions

Apart from the automatically created dimensioning of the section, user-defined dimension lines can be added. The dimensions may refer to nodes, auxiliary points or some results data (e.g. centroid C , shear center M).



The function to set dimension lines is called up via menu

Insert → Dimensions

or the corresponding button in the toolbar.

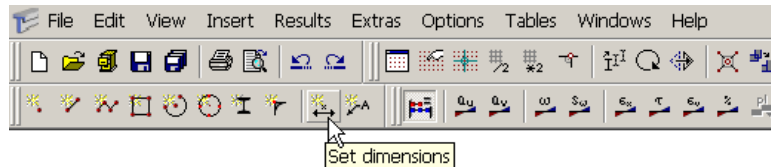

Figure 10.58: Button *Set dimensions*

The *Dimensions* dialog box appears.

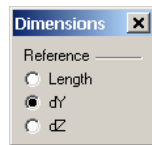

Figure 10.59: Dialog box *Dimensions*

Click the two objects (nodes, auxiliary points etc.) that represent the reference nodes of the new dimension line. Either the true length or the projection in the direction of one of the global axes can be selected as *Reference*.

The offset of the dimension line from the first selected object is determined by moving the mouse pointer in the graphics. The dimension line is finally set by a mouse click.

The display of the dimension lines is controlled in the *Display* dialog box or the general context menu in the work window.

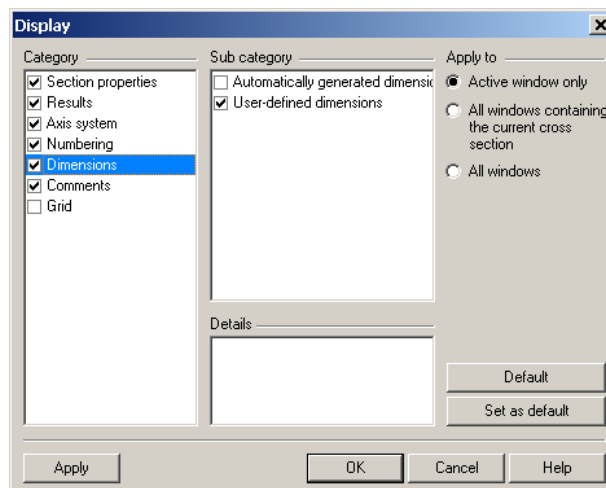

Figure 10.60: Dialog box *Display*: Category *Dimensions*



The dimension lines will be adjusted automatically when changes in the sectional geometry occur.

If you want to modify the offset of a dimension line or refer it to different objects, you have to delete the dimension line and define it again.

10.4.5 Comments

Two different types of comments are available: Texts can be inserted both in the graphics and in the comment boxes of the dialog boxes and tables (as seen e.g. in Figure 5.4 on page 66). This chapter deals with the comments in the graphical user interface.

Comments can be arranged for nodes, auxiliary points, elements and point elements via the snap function or can be placed arbitrarily in the current work plane.

The comment function can be called up via menu

Insert → Comment

or the corresponding button in the toolbar.

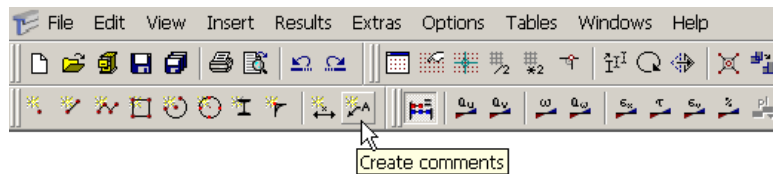

Figure 10.61: Button *Create comments*

The dialog box *Comment Text* appears.

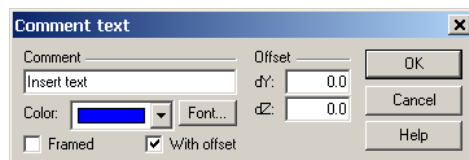

Figure 10.62: Dialog box *Comment text*

The *Comment* is entered in the respective input field. *Color*, [Font] and font size of the text can be specified in detail. Optionally, a *Frame* can be set around the comment.

If the check box *With offset* is activated, the comment will be arranged at a certain distance of the selected object. This distance can also be defined graphically: Click the relevant object first and then define the distance of the comment by a second click.

The display of the comments is controlled in the *Display* dialog box (cf Figure 10.60, page 194) or the general context menu which can be called up by a right-mouse click into an 'empty' area of the work window.

A comment can be edited at a later time by double-clicking it. If the offset is to be modified, a redefinition will be necessary.



10.4.6 Measure Function



Distances and angles can be measured in order to check the data. This function can be activated in the **Extras** menu.

There are three options available to measure the

- *Distance* between two objects (nodes, auxiliary points, centroid, shear center),
- *Angle* between three nodes,
- *Angle* between two elements.

Click the relevant objects one after another. The detailed result will be shown.

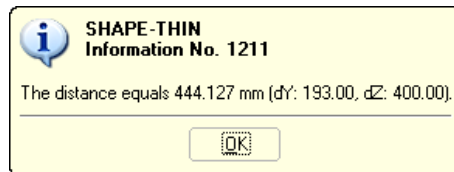

Figure 10.63: Information on *Distance*

10.4.7 Find Objects



The tables can be used when certain objects are searched for. If the cursor is positioned in a table line, the corresponding object will be highlighted in the graphics. It is important that the synchronization of the selection has been activated (see chapter 10.3.4, page 187). With this method, objects can be easily located in the graphics.

SHAPE also has an extra search function which is called up via menu **Extras** → **Find**.

The following dialog box appears.

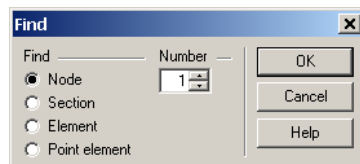

Figure 10.64: Dialog box *Find*

The *Find* list controls whether a node, section, element or point element is to be searched for. Its *Number* can be entered in the input field next to it.



After [OK], the sought-after object will be marked by an arrow in the graphics.

11. Interfaces

It is possible to exchange data between SHAPE and other programs. This allows for the use of templates that have been created in CAD applications. Moreover, the results data of SHAPE can be made available for add-on design software.

The sectional data of previous versions of SHAPE can also be accessed. You can import the input data from the DOS versions **SHAPE 1.xx/2.xx** or directly open **SHAPE 5.xx/6.xx** files in order to calculate the effective widths, for example.

There are interfaces to other programs of the DLUBAL family. On the one hand, the internal forces of members can be imported from RSTAB or RFEM. This is described in chapter 5.7 on page 88. On the other hand, the characteristics of user-defined SHAPE sections are available in RSTAB or RFEM and can be allocated to members. Several add-on modules allow for the design of SHAPE members, too.

For details on how to export print data as **RTF file**, see chapter 9.1.10 on page 159.

Moreover, SHAPE can be run externally via a programmable interface based on COM technology (e.g. Visual Basic). The additional module **DU-COM** (not contained in SHAPE) allows for user-defined input macros and follow-up programs.

The data import is started via menu

File → Import.

The common Windows *Open* dialog box appears.

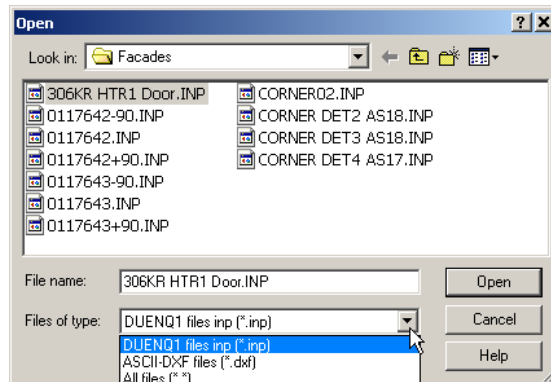

Figure 11.1: Dialog box *Import*

SHAPE files can be exported via menu

File → Export.

The common Windows *Save As* dialog box is opened.

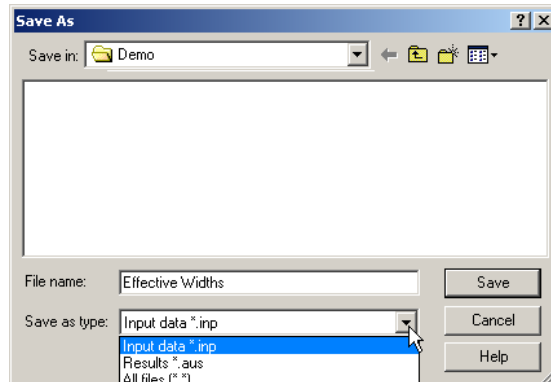

Figure 11.2: Dialog box *Export*

11.1 DLUBAL ASCII Files *.inp / *.aus

SHAPE 5/6 and SHAPE 7 can be installed parallel (cf chapter 2.2.4, page 10). If projects have been created in the Project Manager of SHAPE 5/6, they are automatically shown with the contained sections in the Project Manager of SHAPE 7.

Import



SHAPE 1/2 files in the DOS format *.inp can be imported via menu

File → Import.

The dialog box shown in Figure 11.1 opens in which the folder and the file name of the DOS section can be selected. The *Files of type DUENQ1 files inp (*.inp)* are preset.

After [Open], the dialog box *New Cross-Section - General Data* appears with the *Section* name of the DOS file. This section will be automatically integrated in the current project, which can be changed via the *Project* list.



If several DOS files are to be imported, it is recommended to connect the entire project via the Project Manager. Details on this feature can be found in chapter 4.4.1.1 on page 48.

Export



SHAPE 7 files can be exported to the ASCII format *.inp and *.aus via menu

File → Export.

The dialog box shown in Figure 11.2 opens in which the folder and the file name of the ASCII data can be selected. Among the *Files of type* list, three control options are available:

- *Input data *.inp* creates an ASCII file with the input data only.
- *Results *.aus* creates an ASCII file with the results data only.
- *All files *.** creates two ASCII files that contain the input and results data each.



Alternatively, the SHAPE tables can be exported to an MS Excel™ file *.xls. For details on this function, see chapter 10.3.6 on page 189.

11.2 ASCII Files *.dxf

Via the DXF interface, templates of sections can be imported that have been created in CAD applications. The DXF format transfers the general information on the lines of a section.



It is advisable to use a 'cleaned-up' DXF file for the import. If necessary, delete e.g. dimension lines or comments in the DXF file as those are irrelevant for SHAPE. To avoid problems, complex objects should also be dismantled (via *Explode* in AutoCAD™, for example).



Files in the format *.dxf can be imported via menu

File → Import.

This calls up the dialog box shown in Figure 11.1 where the *Files of type ASCII DXF files (*.dxf)* can be selected. Before the actual import, a new section has to be defined in SHAPE.



If the DXF template is to be applied for the current SHAPE section, however, it can be imported via menu

File → Load DXF template or
Extras → Load DXF template.

The Windows *Open* dialog box appears in which the folder and the name of the *.dxf file can be selected. After [OK], the *Import DXF template* dialog box is called up.

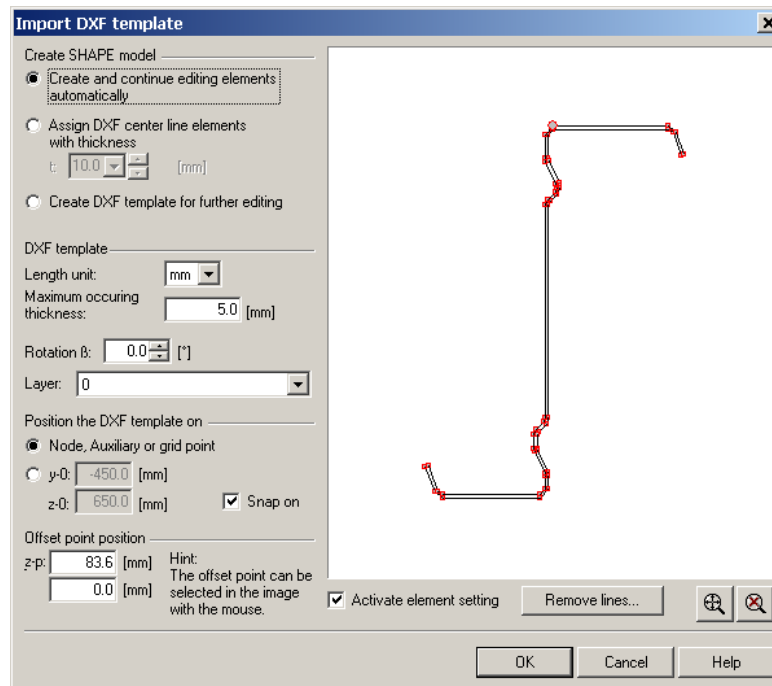
Figure 11.3: Dialog box *Import DXF template*

In the dialog section *Create SHAPE model*, there are three options available:

- *Create elements automatically* converts parallel lines of the DXF model to elements.
- *Assign element thickness to center lines* applies a uniform thickness to all lines.
- *Create DXF template for further editing* only generates a layer.



Detailed settings control the conversion of the *DXF template*. Apart from the *Length unit*, the *Maximum occurring thickness* is decisive for the automatic detection of parallel elements. If the allowance is too large, defective elements may be created.

For the template, a convenient angle of *Rotation* β can be defined. If there are several layers in the template, the relevant *Layer* is to be selected from the list.

It is possible to *Position the DXF template* on a node, auxiliary or grid point or on a user-defined point by entering its coordinates y_0 and z_0 .

The location of the *Offset point* can be defined in the template coordinate system y_p and z_p or simply picked in the image of the template.

The [Remove lines] button calls up an extra dialog box in which irrelevant lines of the template can be deleted by left mouse clicks.

After [OK], SHAPE tries to automatically convert as many elements as possible. Center lines are created from parallel lines, and nodes of elements are created at their intersections. If not all lines can be converted to elements, a message appears that the DXF template has not been correctly defined. This means that some reworking of the section is required.

If the option *Activate element setting* has been enabled in the *Import DXF template* dialog box, the following dialog box is called up after the conversion.

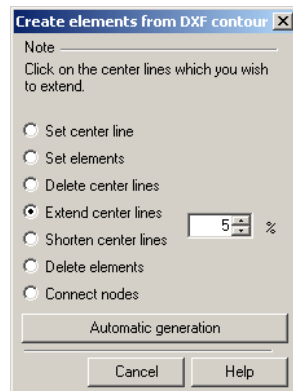

Figure 11.4: Dialog box *Create elements from DXF contour*

Set center lines allows for manually defining center lines by selecting the two parallel DXF lines one after another.

If there is no intersection between center lines, it is possible to *Extend* one (or both) lines by a percentaged value. This can be done by clicking on the side of the line – repeatedly, if necessary – until the intersection has been reached.

To *Set elements* on the center lines between two intersection nodes, simply click the relevant center lines.

The option *Connect nodes* inserts a new element with an intermediate thickness between two nodes that have been created with their elements.

The [Automatic generation] is the default setting when importing DXF files. Via this button, the elements can be created once again after having reworked the center lines.



Please note that sectional models with irregular contours may be problematic. Parallel lines or arcs in the DXF file are prerequisite for a successful conversion into SHAPE elements.



It is possible to subsequently create elements from an imported DXF template via menu

Extras → Set elements from DXF template.

The dialog box as seen in Figure 11.4 is called up.

A Literature

- [1] DASt-Richtlinie 016: Bemessung und konstruktive Gestaltung von Tragwerken aus dünnwandigen kaltgeformten Bauteilen. Deutscher Ausschuss für Stahlbau. Stahlbau-Verlagsgesellschaft, Köln, Juli 1988
- [2] DIN 18 800 Teil 1: Stahlbauten, Bemessung und Konstruktion. November 1990
- [3] GORIS, A.; RICHTER, G.: Schneider-Bautabellen, 14. Auflage, Kapitel 5 B, Stahlbeton- und Spannbetonbau nach DIN 1045-1 (neu). Werner Verlag, Düsseldorf, 2001
- [4] KINDMANN, R.; FRICKEL, J.: Elastische und plastische Querschnittstragfähigkeit. Grundlagen, Methoden, Berechnungsverfahren, Beispiele. Verlag Ernst & Sohn, Berlin, 2002
- [5] LINDNER, J., SCHEER, J., SCHMIDT, H.: Erläuterungen zu DIN 18800 Teil 1 bis Teil 4. Beuth-Kommentare. Verlag Ernst & Sohn, Berlin, 1998
- [6] MAIER, W., WEILER, P.: Bemessungshilfen für den Nachweis von Stabquerschnitten im plastischen Zustand nach DIN 18 800, November 1990. Forschungsbericht 2/1997. Deutscher Ausschuss für Stahlbau
- [7] OSTERRIEDER, P.: Tragfähigkeit von Stahlquerschnitten mit Schnittkraftinteraktion. Wissenschaft und Praxis, Veröffentlichung der Fachhochschule Biberach, 24. Stahlbauseminar 2002, S. 6-1 bis 6-10
- [8] OSTERRIEDER, P., WERNER, F., KRETZSCHMAR, J.: Biegedrillknicknachweis Elastisch-Plastisch für gewalzte I-Querschnitte. Stahlbau 67 (1998), H. 10, S. 794-801
- [9] PETERSEN, C.: Stahlbau. Grundlagen der Berechnung und baulichen Ausbildung von Stahlbauten. Verlag Vieweg & Sohn, Braunschweig/Wiesbaden, 1993

B Index

A

Arc	77, 83
Arc Elements	58, 60
Archive Data	52
Area	74, 78, 81, 94
Area Bisecting Axes	103
ASCII File	198
Auxiliary Point	75, 79
Axial Force	84, 107
Axis y	55

B

BauText	159
Bending	124
Bending Moment	86, 108, 109
Beuth Comment	60, 121
Bimoment	86
Block Functions	183
Boundary Stresses	128, 135
Bredt	97, 111, 126
Buckling Curves	57, 104
Buckling Factor k_G	132, 135
Button	33

C

c/t Check	55, 60, 69
c/t Ratio	83, 121
c/t Zone	61, 62, 82, 120, 128, 134
Calculate	54
Calculation Theory	91, 122
Cartesian Coordinate System	66, 174
Category	140, 191, 192
Cell	97, 100, 106, 111, 126
Center Lines	58, 199, 200
Centroid	95
Change Section Description	51
Check Box	34
CHS	83, 180
Circle	80
Circular Hollow Section	83, 180
Classification	127, 130
Clipboard	163

Color Print	165
Color Spectrum	40, 139, 145, 166
COM Interface	197
Comment	195
Company Address	153
Composite Sections	122
Compression Zone Factor α	121, 128
Connect Elements	176
Connect Folder	48
Connect Node	177
Contained Elements	123
Context Menu	33, 45, 182, 183
Control Panel	145, 166
Coordinate System	66
Copy	168
Copy Section	50
Corners	175
Correction Factor η	58
Create Project	48
Create Section	53
Crossing Elements	90
Cross-Section Library	74
Current Project	47
Czech	193

D

Dearchive Data	52
Decimal Places	193
Default Buttons	43
Delete Project	49
Delete Section	51
Description	135, 152
Design Method	60
Design Stress $f_{y,d}$	69
Details	56
Determine Stresses	58
Dialog Input	64
Dialog Section	33
Dimensions	194
Direction	78
Disconnect Folder	49
Discretization Settings	60

Displacement Vector.....	168	German	160, 193
Display Objects	191	Graphic Input.....	64
Display Settings	192	Graphic Printout.....	161
Distance.....	107, 110	Graphics	139
Distribution.....	139	Gray Scales	165
Divide	170	Grid	174
Division Node	171	Grid Type.....	174
Dummy Element	75, 77, 91, 171, 176, 178	Grouping.....	143, 144
DXF File.....	198	H	
DXF Template	198, 199, 200	Header Printout Report	152, 162
E		Header Template	153
Effective Cross-Section.....	55, 61, 69, 94, 131	I	
Effective Thickness.....	77, 97, 110, 113	Ideal Section Properties... 56, 68, 94, 104, 123	
Effective Widths.....	131, 133, 136	Image Size.....	163
Elastic Modulus	69	Imperfection Factor α	57
Elastic Section Moduli.....	100	Import	189, 197, 198
Element Direction	105	Import Internal Forces	87
Element Edges	58	Inclination	95
Element Info	141	Input Field	34
Element Number.....	76	Input Tables	65
Element Orientation	77	Insert.....	79
Elements.....	58, 76, 83, 127, 132, 199	Installation	9
End Restraint	61, 62	Interconnecting Elements.....	91
English	160, 193	Interfaces	197
Enlargement Factor	116, 118	Internal Divisions.....	58
Equivalent Stresses	57, 114, 115	Internal Forces.....	84
Excel	188, 189	Intersecting Elements.....	176
Expand Material Library.....	71	Intersections.....	176
Export.....	189, 197, 198	Iso-surfaces	139
Export Printout Report.....	159	I_T Calculation	58
Extend Element.....	177	K	
Extremes	107, 110, 114	Keyboard Functions.....	44
F		L	
Favorites Material	70	Language Settings.....	160, 193
FEA calculation	58	Lateral Restraint D.....	56, 85
File Location.....	54	Layout	158
Fillet.....	79	Length.....	78, 80
Filter	42, 140, 143, 145, 188	Limit Stresses.....	70, 109, 112, 115
Filter Functions	144, 188	Limiting Proportions λ	128
Find Objects.....	196	List	34
Fonts.....	141	Load Case.....	84, 86, 107, 110, 120, 151, 152
G		Load Combination.....	88
General Data.....	53, 54	Location x.....	84, 86, 88, 107, 110, 138

Logo	153	Plastic Moments	101
Long Arc	78	Plastic Reserve Capacities	102
M		Plastic Section Moduli	102
Material	68, 73, 76, 81	Plastic Section Properties	54
Material Description	68	Plastic Shear Areas	103
Material Factor ϵ	128	Plastic Shear Force	103
Material Library	70	Plastic Stresses	118
Measure Function	196	Plate Slenderness $\lambda_{p,\sigma}$	133, 135
Member	88	Plausibility Check	90
Mirror	169	Point Elements	58, 79
Moments of Inertia	95, 96, 123	Polar Coordinate System	67, 174
Monochrome Print	165	Position	81
Move	168	Position Offset Point	73
Multicolor Display	139	Primary Torsional Moment	85
Multiple Windows View	142, 162	Principal Axis	95
N		Principal Axis Coordinates	68
Navigator	38	Principal Axis Inclination α	58
Network Sections	63	Print Images	154, 161
New Page	148	Print Quality	165
Nodal Coordinates	67	Printing	158
Node Number	66	Printout Report	146, 150, 151
Nodes	66	Printout Report Template	157
Normal Stresses	107, 108, 114, 121	Project	54
Number of Iterations	62	Project Description	48, 49, 152
O		Project Manager	46, 198
Offset Point	73, 75, 79, 80, 199	R	
Open Section	50	Radii of Gyration	96
Opening	171	Radius	78, 80
Orientation	77	Rectangle	80
P		Rectangular Hollow Section	179
Page Numbering	152	Reduce Section	75, 172
Panel	40	Reduction Factor	101
Parallel Axis Theorem	91, 95, 99, 123	Reduction Factor ρ	133, 136
Parallel Elements	179	Reference Material 56, 94, 104, 109, 114, 123	
Parallel Installation	10	Reference Node	67
Partial Safety Factor γ_M	57	Reference of Internal Forces	56
Particle Info	142	Reference Point	173
PDF Print	160	Remove	79
Perimeter	97	Rename Project	50
Pipes	180	Rename Section	51
Plastic Axial Force	104	Restraint Type	120, 127, 132, 134
Plastic Calculation	91	Restraints	83
Plastic Capacity	55, 59, 69, 116	Results	93, 138

Results Display	139	Smoothen Corners	175
Results Evaluation	138	Snap	174
Results Values	138, 141	Special Selection	144, 167
Rhomboid	167	Specific Weight	69
RHS	179	St. Venant	58, 111, 126
Right Side	78	Start Calculation	92
Rise	78	Statical Moments	105
Rotate	169	Status	79
Rotation	73, 75, 81	Status Bar	39
Round Corners	175	Straight	83
Rounding	80	Stress Diagrams	139
Row	181, 186	Stress Points	58
RTF File	156, 159, 197	Stress Ratio	109, 112, 115
S		Stress Ratio ψ	62, 121, 128, 132, 135
Safety Factor γ_M	69	Structure Description	54
Saint Venant	97	Subtracted Length	83, 120, 127, 132, 134
Scaling	140, 173	System Requirements	9
Search Function	196	T	
Secondary Torsional Moment	85	Tab	33
Section Characteristics Diagrams	139	Table Functions	181
Section Description	73	Table Settings	186, 187
Section Library	73, 74	Tables	39, 186
Section Properties	93	Tabular Input	183
Section Ranges	101	Text Files	156
Sections	73, 74, 144, 171	Thickness	77, 83, 121, 128, 132, 135
Selection	167, 187	Thickness-Related Stresses	69
Selection Field	35	Toolbar	36, 37
Selection Printout Report	148, 151	Tooltip	36
SHAPE 6	10, 198	Torsion	125
Shear Areas	94	Torsional Constant	97, 123
Shear Center	98, 123	Torsional Moment	84, 101, 111, 112
Shear Flow	77, 171	Torsional Section Modulus	100
Shear Forces	84, 110, 112, 113, 124	Tresca	57, 118, 119
Shear Modulus	69	Triangle	80
Shear Stresses	110, 112, 115, 126	Type c/t Zone	83
Shear Wall	108	Type Point Element	80
Shear Wall Section	122	U	
Shear Wall Theory	91, 122	Units	193
Short Form Printout	162	Unutilized Reserve	119
Sigma-equiv	57, 115	Updates	10
Sign Convention	55, 86	V	
Simplex Elements	59, 60, 91, 116, 119, 142	Value Spectrum	41
Smooth Color Transition	41	von Mises	57, 117, 118

W

Warp Rotation 99
Warping Bimoment 108
Warping Constant 99, 123
Warping Ordinates 106
Warping Section Modulus 100
Warping Statical Moments 106
Warping Torsion 85, 86, 125
Weight 97

Welds 57, 115
Width 80, 83, 120, 127, 132, 135
Width-to-Thickness Ratio 60, 83, 121, 128
Window Arrangement 162, 163

Y

Yield Criteria 115, 116
Yield Stress $f_{y,k}$ 69

Z

Zone 120, 127, 131, 134