

Version
December 2011

Add-on Module

ALUMINIUM

**Ultimate Limit State and
Serviceability Limit State Design
according to Eurocode 9**

Program Description

All rights, including those of the translation, are reserved.
No portion of this book may be reproduced – mechanically,
electronically, or by any other means, including photocopying –
without written permission of ING. SOFTWARE DLUBAL.

© Ing. Software Dlubal

Am Zellweg 2 D-93464 Tiefenbach

Tel: +49 (0) 9673 9203-0
Fax: +49 (0) 9673 9203-51
E-mail: info@dlubal.com
Web: www.dlubal.com

Contents

Contents		Page	Contents		Page
1.	Introduction	4	5.	Evaluation of Results	42
1.1	Add-on Module ALUMINIUM	4	5.1	Results on RSTAB Model	43
1.2	ALUMINIUM Team	5	5.2	Result Diagrams	45
1.3	Using the Manual	5	5.3	Filtering Results	46
1.4	Starting ALUMINIUM	6	6.	Printout	48
2.	Input Data	8	6.1	Printout Report	48
2.1	General Data	8	6.2	Print ALUMINIUM Graphics	48
2.1.1	Ultimate Limit State	8	7.	General Functions	50
2.1.2	Serviceability Limit State	10	7.1	ALUMINIUM Design Cases	50
2.1.3	National Annex (NA)	11	7.2	Cross-Section Optimization	52
2.2	Materials	12	7.3	Import and Export of Materials	54
2.3	Cross-Sections	14	7.4	Units and Decimal Places	55
2.4	Lateral Intermediate Supports	17	7.5	Export of Results	55
2.5	Effective Lengths - Members	18	8.	Example	57
2.6	Effective Lengths - Sets of Members	22	A	Literature	69
2.7	Nodal Supports - Sets of Members	23	B	Index	70
2.8	Member Releases - Sets of Members	25			
2.9	Serviceability Data	26			
3.	Calculation	27			
3.1	Details	27			
3.1.1	Ultimate Limit State	27			
3.1.2	Stability	28			
3.1.3	Serviceability	30			
3.1.4	Other	31			
3.2	Start Calculation	32			
4.	Results	34			
4.1	Design by Load Case	34			
4.2	Design by Cross-Section	35			
4.3	Design by Set of Members	36			
4.4	Design by Member	36			
4.5	Design by x-Location	37			
4.6	Governing Internal Forces by Member	38			
4.7	Governing Internal Forces by Set of Members	39			
4.8	Member Slendernesses	39			
4.9	Parts List by Member	40			
4.10	Parts List by Set of Members	41			

1. Introduction

1.1 Add-on Module ALUMINIUM



Eurocode 9 determines rules for the design, analysis and construction of aluminium structures in all member states of the European Union. With the add-on module ALUMINIUM from the company ING. SOFTWARE DLUBAL all users obtain a highly efficient and universal tool to design aluminium structures according to this standard. The rules specific for particular countries are set in national annexes. In ALUMINIUM a great number of national annexes is already available. It is also possible for the user to define limit values and create new national annexes in the module.

All typical designs of load capacity, stability and deformation are carried out in the module ALUMINIUM. Different actions are taken into account during the load capacity design and there is the possibility to choose some interaction designs for a given standard. The allocation of designed cross-sections into classes 1 to 4 makes an important part of the design according to Eurocode 9. The purpose of this classification is to determine the range in which the local buckling in cross-section parts limits the load capacity so that the rotational capacity of cross-sections can be verified. Further, ALUMINIUM automatically calculates the c/t ratios of compressed parts and carries out the classification automatically.

For the stability design, you can determine for every single member or set of members whether buckling is possible in the direction of y-axis and/or z-axis. Lateral supports can be added for a realistic representation of the structural model. All comparative slendernesses and critical loads are automatically determined by ALUMINIUM on the basis of the boundary conditions. For the design of lateral torsional buckling, the elastic critical moment that is necessary for the design is calculated automatically. It can also be entered manually. The location where the loads are applied, which influences the elastic critical moment, can also be defined in the detailed settings.

The serviceability limit state has become important in modern civil engineering as more and more slender cross-sections are being used. In ALUMINIUM, load cases and groups and combinations of load cases can be arranged individually to cover the various design situations.

Like other modules, ALUMINIUM is fully integrated into the RSTAB program. However, it is not only an optical part of the program. Results from the module can be incorporated to the central printout report. Therefore, the entire design can be easily – and uniformly – organized and presented.

The program includes an automatic cross-section optimization and a possibility to export all modified profiles to RSTAB.

Individual design cases make it possible to flexibly analyze separate parts of extensive structures.

We wish you much success and delight when working with our module ALUMINIUM.

Your ING. SOFTWARE DLUBAL company.

1.2 ALUMINIUM Team

The following people participated in the development of the ALUMINIUM module:

Program Coordinators

Dipl.-Ing. Georg Dlubal
 Ing. Ph.D. Martin Čudejko

Dipl.-Ing. (FH) Younes El Frem
 Ing. Pavol Červeňák

Programmers

Ing. Zdeněk Kosáček
 Ing. Ph.D. Martin Čudejko
 Zbyněk Zámečník
 Dr.-Ing. Jaroslav Lain

Ing. Martin Budáč
 Mgr. Petr Oulehle
 Ing. Roman Svoboda
 DiS. Jiří Šmerák

Library of Cross-Sections and Materials

Ing. Ph.D. Jan Rybín

Jan Brnušák

Design of Program, Dialog Boxes and Icons

Dipl.-Ing. Georg Dlubal
 MgA. Robert Kolouch

Ing. Jan Milěš

Testing and Technical Support

Ing. Ctirad Martinec
 Ing. Ph.D. Martin Čudejko
 Dipl.-Ing. (FH) Steffen Clauß
 Dipl.-Ing. (FH) Matthias Entenmann
 Dipl.-Ing. (FH) René Flori

Dipl.-Ing. (FH) Walter Fröhlich
 Dipl.-Ing. (BA) Andreas Niemeier
 Dipl.-Ing. (FH) Walter Rustler
 M. Sc. Dipl.-Ing. (FH) Frank Sonntag
 Dipl.-Ing. (FH) Christian Stautner

Manuals, Documentation and Translations

Ing. Ph.D. Martin Čudejko
 Ing. Ladislav Kábrt
 Ing. Mgr. Hana Macková
 Ing. Petr Míchal

Mgr. Michaela Kryšková
 Mgr. Petra Pokorná
 Dipl.-Ing. (FH) Robert Vogl
 Dipl.-Ü. Gundel Pietzcker

1.3 Using the Manual

All general topics such as installation, user interface, results evaluation and printout report are described in detail in the manual of the main program RSTAB. Hence, we omit them in this manual and will focus on typical features of the add-on module ALUMINIUM.



During the description of ALUMINIUM, we use the sequence and structure of the different input and output tables. We feature the described **icons** (buttons) in square brackets, e.g. [Pick]. The buttons are simultaneously displayed on the left margin. The **names** of dialog boxes, tables and particular menus are marked in *italics* in the text so that they can be easily found in the program.

The index at the end of this manual enables you to quickly look up specific terms.

1.4 Starting ALUMINIUM

It is possible to initialize the add-on module ALUMINIUM in several ways.

Main Menu

You can call up ALUMINIUM by the command from the main menu of the RSTAB program:

Additional Modules → Design - Aluminium → ALUMINIUM.

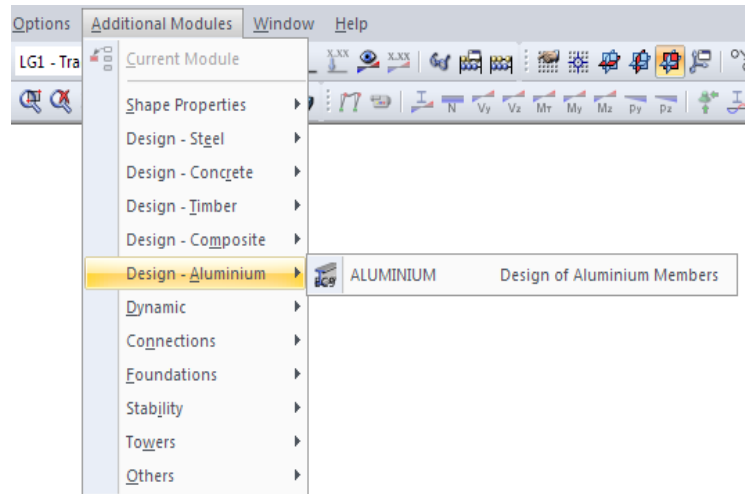

Figure 1.1: Main Menu: *Additional Modules → Design - Aluminium → ALUMINIUM*

Navigator

Further, it is possible to start ALUMINIUM from the *Data* navigator by clicking on the item

Additional Modules → ALUMINIUM.

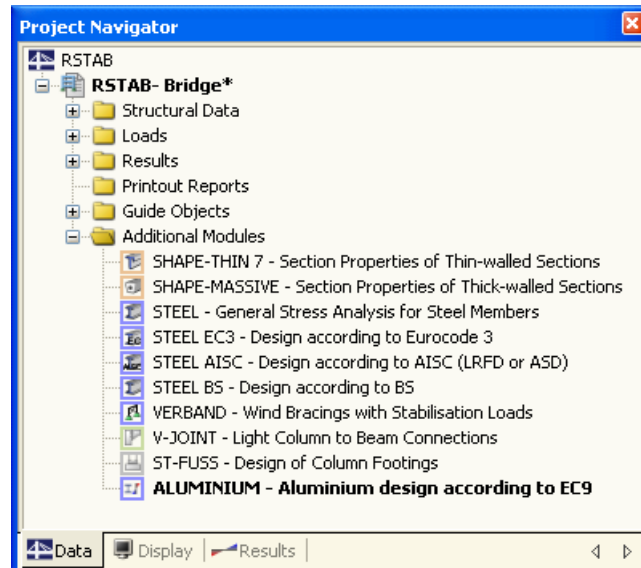

Figure 1.2: Data Navigator: *Additional Modules → ALUMINIUM*

Panel

If results of ALUMINIUM are already available in the RSTAB position, you can set the relevant design case of this module in the list of load cases in the menu bar. The design criterion on members is displayed graphically in the work window of RSTAB by using the [Results on/off] button.

The [ALUMINIUM] button that enables you to start of ALUMINIUM is available in the panel.

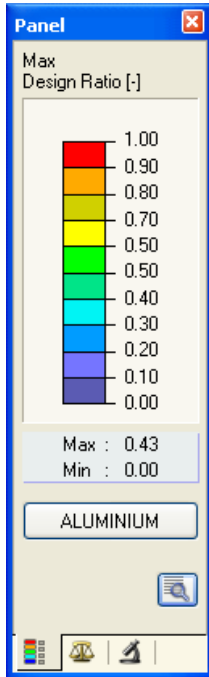
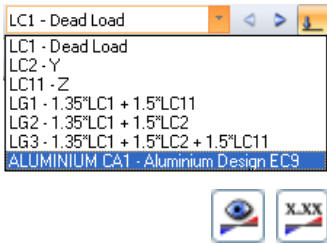

Figure 1.3: [ALUMINIUM] button in Panel

2. Input Data



The data of the design cases is entered in different tables of this module. Furthermore, the graphic input using the function [Pick] is available for members and sets of members.

After the initialization of the ALUMINIUM module, a new window is displayed. In its left part, a navigator is shown that enables you to access all existing tables. The roll-out list of all possibly entered design cases is located above this navigator (see chapter 7.1, page 50).

If ALUMINIUM is called up for the first time in a position of RSTAB, the following important data is loaded automatically:

- Members and sets of members
- Load cases, load groups and load combinations
- Materials
- Cross-sections
- Internal forces (in the background – if calculated)



You can switch among the tables either by clicking on individual navigator items of ALUMINIUM or by using the buttons visible on the left. The [F2] and [F3] function keys can also be used to browse the tables in both directions.

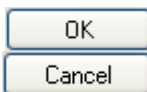

Save entered data by the [OK] button and close the module ALUMINIUM, while by the [Cancel] button you terminate the module without saving the data.

2.1 General Data

In the table 1.1 *General Data*, members, sets of members and actions are to be selected for the design. You can specify load cases, groups and combinations for the ultimate limit state and the serviceability limit state design separately in the corresponding tabs.

2.1.1 Ultimate Limit State

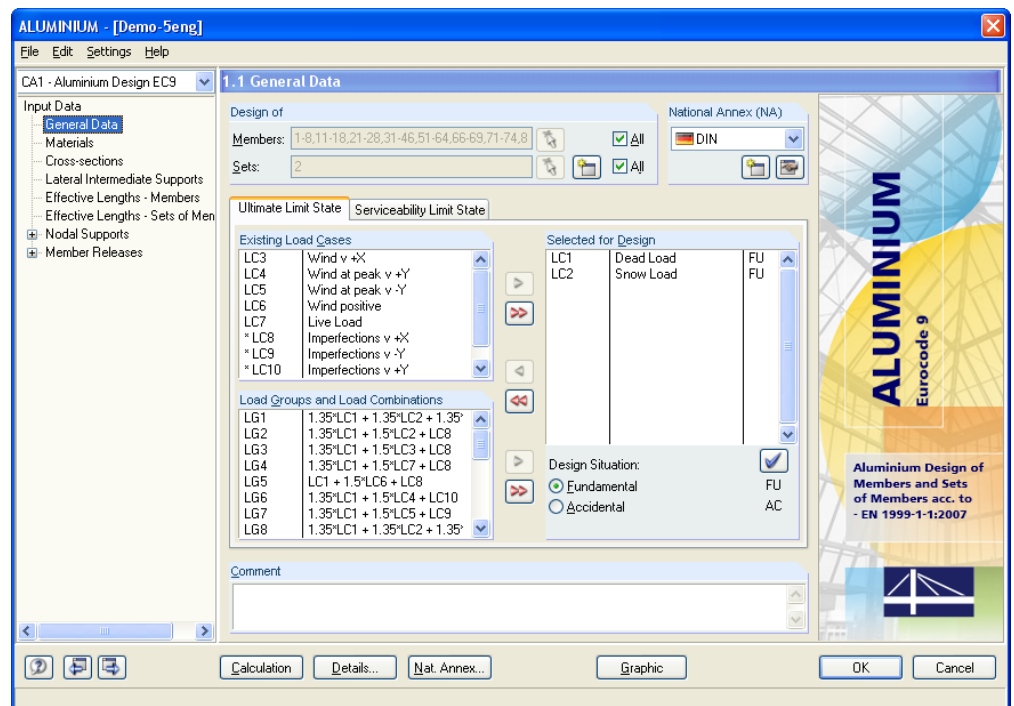

Figure 2.1: Table 1.1 *General Data*, *Ultimate Limit State* tab

Design of



You can select both *Members* and *Sets of Members* for the design. If only specific objects are to be designed, it is necessary to clear the check box *All*. By doing so, both input boxes become accessible and you can enter the numbers of the relevant members or sets of members there. With the [Pick] button, you can also select members or sets of members graphically in the RSTAB work window. To rewrite the list of default member numbers, select it by double-clicking it, and then enter the relevant numbers.



If no sets of members were defined in RSTAB yet, they can be created in ALUMINIUM via the [New Set of Members...] button. The familiar RSTAB dialog box to create a new set of members opens in which you enter the relevant data.

Designing a set of members has the advantage that the total maxima of the design ratios is determined of all members contained in the set. In this case, the results tables 2.3 *Design by Sets of Members*, 3.2 *Governing Internal Forces by Set of Members* and 4.2 *Parts List by Set of Members* are displayed additionally.



National Annex (NA)

This list box controls the national annex which is to be applied for the design parameters and limit deformations.

Use the [Edit] button open a dialog box in which you can check or modify the settings of the selected national annex. This dialog box is explained in chapter 2.1.3 on page 11.



Existing Load Cases / Load Groups and Load Combinations

All design-relevant load cases, load groups and load combinations that were created in RSTAB are listed in these two sections. The [▶] button moves the selected load cases, load groups or load combinations to the list *Selected for Design* on the right. Single items can be also transferred by double-clicks. The [▶▶] button moves all items to the list on the right.

If an asterisk (*) is displayed at load cases or combinations, as you can see e.g. in Figure 2.1 at load cases 8 to 10, they are excluded from the design. It signifies that no loads were assigned to these load cases or that they contain only imperfections (as in our example).

Please note that only load combinations can be chosen whose minimum and maximum values can be determined unambiguously (i.e. alternative combinations with the combination criterion *Permanent*). This restriction is necessary because the calculation of the elastic critical moment at lateral buckling requires the unambiguous assignment of moment diagrams. If an invalid load combination is selected, the following warning appears:

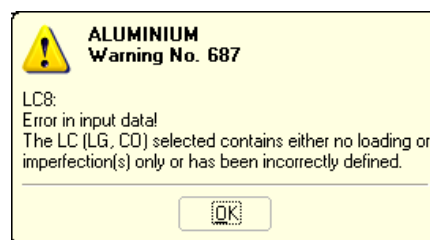

Figure 2.2: Warning when selecting invalid LC, LG or CO

A multiple choice of load cases can be done by using the [Ctrl] key, as a routine procedure in Windows. Hence, you can select and transfer several load cases to the list on the right simultaneously.

Selected for Design



The loads selected for the design are listed in the right column. By the [◀] button you can remove the selected load cases, load groups or combinations from the list. As before, they can be transferred by double-clicks. The [◀◀] button removes all items from the list.



Generally, the calculation of an enveloping *Or* load combination is faster than the analysis of all contained load cases or groups. On the other hand, you must keep in mind the above-mentioned restriction: to determine the maximum or minimum values unambiguously, the *Or* load combination must only contain load cases, groups or combinations which enter the combination with the criterion *Permanent*. Moreover, the design of an enveloping load combination makes it a bit difficult to retrace the influence of the contained actions.

2.1.2 Serviceability Limit State

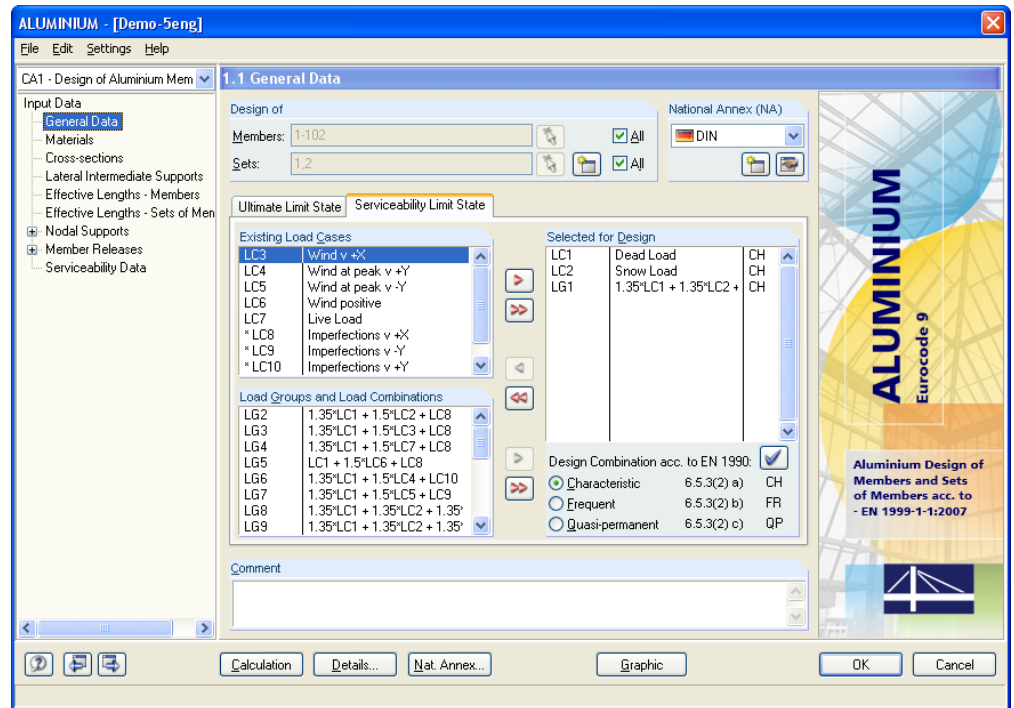

Figure 2.3: Table 1.1 *General Data, Serviceability Limit State* tab

Existing Load Cases / Load Groups and Load Combinations

All load cases, load groups and load combinations that were created in RSTAB are listed in these two sections.

Selected for Design

Adding load cases and their groups and combinations to the list for the design, resp. removing them from the list is done in the same way like in the previous tab (see chapter 2.1.1).

Design Combination acc. to EN 1990

In this dialog section, you can set different limit values that are to be applied for the deflections of combined actions.



The relevant limit value for the selected design combination can be assigned as follows: Click the action in the list *Selected for Design* to select it. Then click the blue tick to allocate the relevant criteria. The limit values are controlled by the National Annex. They they can be modified in the dialog box that contains the parameters of the national annex (see Figure 2.4, page 11).

The governing reference lengths for the SLS design are managed in table 2.9 (see chapter 2.9, page 26).

Comment

In this entry field you can make a comment on the current case in ALUMINIUM.

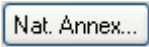

The [Nat. Annex] button enables you to open the dialog box any time to check or modify the following parameters of the current National Annex: partial safety factors, limit values for SLS design and limit ratio for general yield criterion (see chapter 2.1.3).

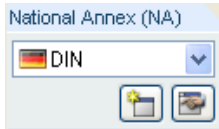

2.1.3 National Annex (NA)

In this list, the *National Annex* can be selected whose design parameters and limit deformation values are to be applied.

Use the [Edit] button to open the dialog box with detailed settings of the selected National Annex (see Figure 2.4). You can also modify some parameters, if necessary.

By the [New] button, it is possible to create a user-defined national annex.

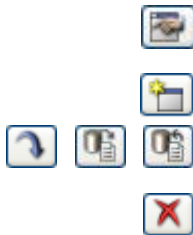

The buttons located in the left bottom corner enable you to save the modified parameters as default or, by contrast, to restore the default settings of the program.

Any user-defined National Annex can be removed by using the [Delete] button.

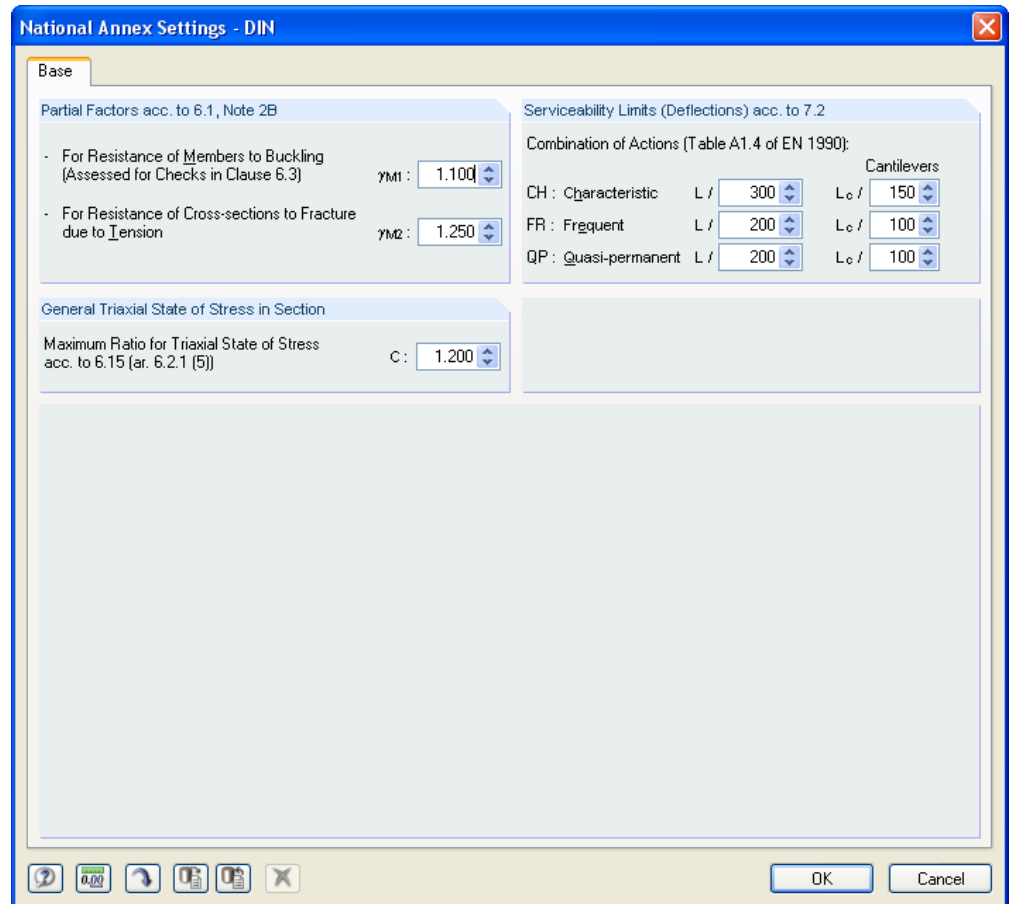

Figure 2.4: Dialog box *National Annex Settings - DIN*

2.2 Materials

This table is divided into two parts. The materials for the design are listed in the upper part. In the lower part, the *Material Properties* of the current material are displayed, i.e. the material whose line is selected in the upper table.

Materials that are not used for the design are written in gray letters. Inadmissible materials are displayed with red, modified materials with blue fonts.

The material properties that are necessary to calculate the internal forces in RSTAB are described in detail in the RSTAB manual, chapter 5.2. The design-relevant material characteristics are stored in the global material library. Those are automatically set as default.

Units and decimal places of the material properties and stresses can be edited from the main menu **Options** → **Units and Decimal Places** (see chapter 7.4, page 55).

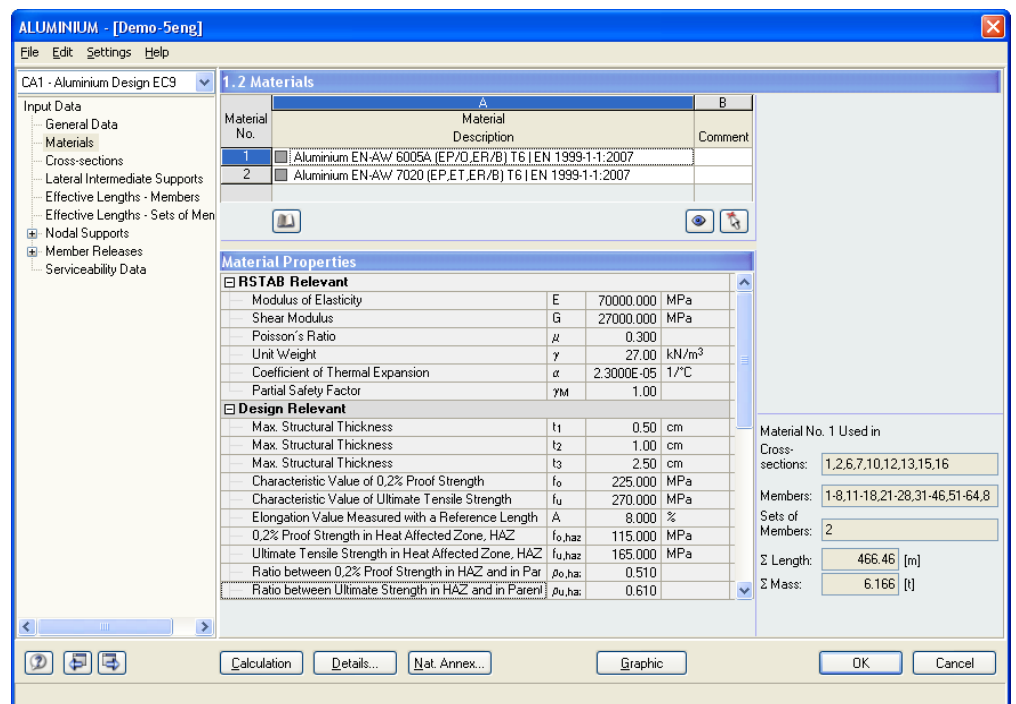

Figure 2.5: Table 1.2 Materials

Material Description

The materials that have been defined in RSTAB are set by default. You can also enter materials manually here. If the *Material Description* corresponds to an entry in the material library, ALUMINIUM automatically imports the relevant material properties.

To select a material from the list, place the cursor in column A and click on the [▼] button or press the [F7] function key. A list is opened that you can see on the left. As soon as you have chosen the appropriate material, the material characteristics are updated in the table below.

This list of materials includes only materials from the category **Aluminium**. How to import materials from the library is described below.

As a matter of principle, it is not possible to edit the material properties in ALUMINIUM.

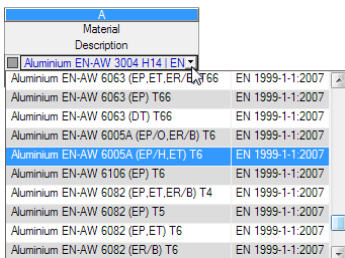

Import Material from Library

A considerable amount of materials is stored in the library. Open the library via menu

Edit → Material Library...

or by clicking on the button visible on the left.

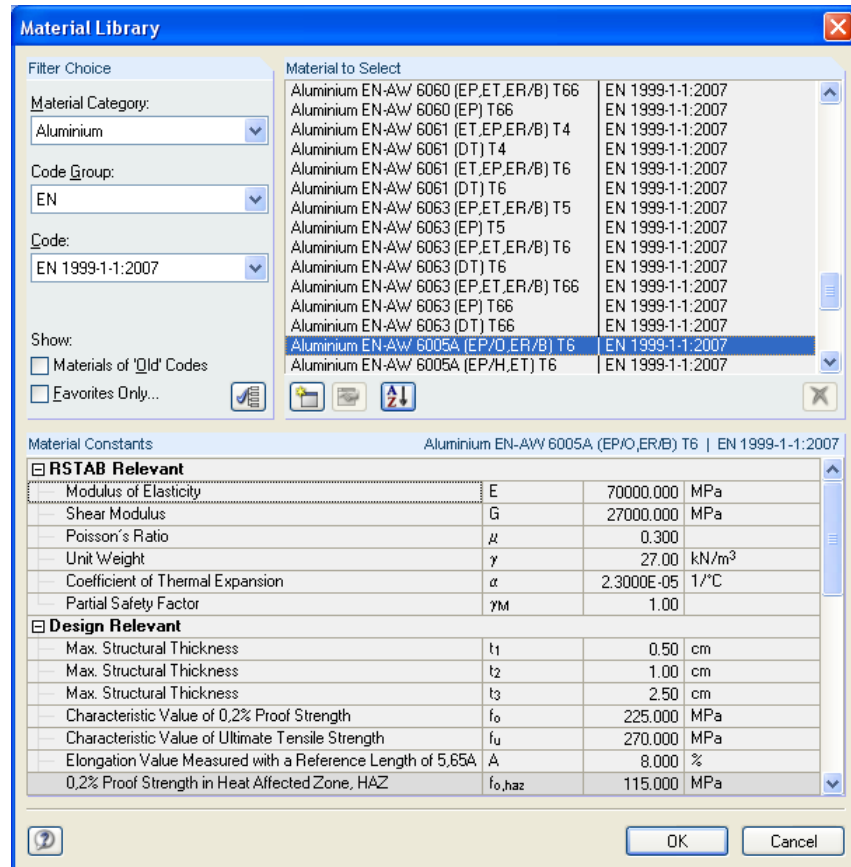
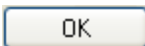

Figure 2.6: Material Library dialog box



In the section *Filter Choice*, the material category *Aluminium* is set by default. In the list *Material to Select* which is located on the right, you can select a particular material, and in the lower part of the dialog box you can check its characteristic values. After clicking on [OK] or pressing the [↵] key, the material is taken over to the table 1.2 of ALUMINIUM.

Chapter 5.2 of the RSTAB manual explains in detail how materials can be filtered, added to the library or newly classified.

Only materials included in EN 1999-1-1 (table 3.2) are supported in ALUMINIUM. Furthermore, it is not possible to modify the material properties in the add-on module.



ALUMINIUM does not check the product form of the material (see [1] Table 3.2b, column *Product form*) and the shape of the cross-section. Thus, the appropriate material has to be selected by the user.

2.3 Cross-Sections

This table controls the cross-sections that are to be designed. The parameters for the optimization can be defined here as well.

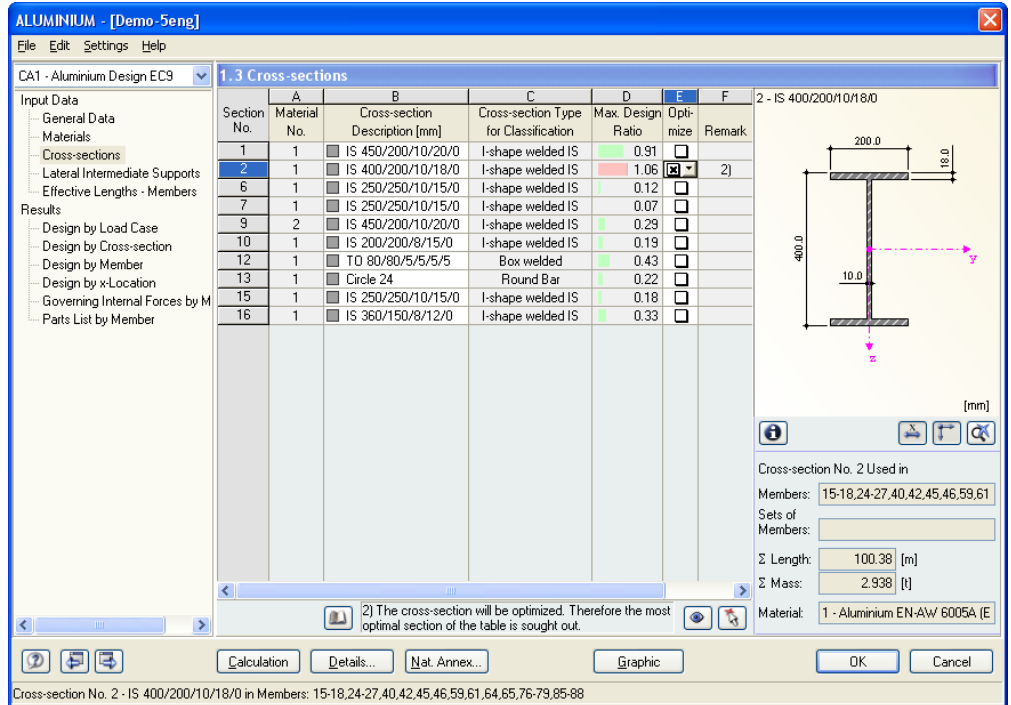

Figure 2.7: Table 1.3 Cross-sections

Cross-Section Description

When you open this table, the sections that were defined in RSTAB are set by default, including the assigned material numbers.

The cross-sections can be changed any time for the design. The description of a modified cross-section is highlighted in blue color.

In order to edit a cross-section, enter the new description in the corresponding line or select the new section from the library. Open this library as in RSTAB by clicking on the [Import Cross-Section from Library...] button. Alternatively, place the cursor in the corresponding line and click on the [...] button or press the [F7] key. The RSTAB library resp. the dialog box with the cross-section table of the input line opens.

Chapter 5.3 of the RSTAB manual describes in detail how cross-sections can be selected from the library.

ALUMINIUM allows for the comprehensive design of the following types:

- I sections: rolled/welded, doubly symmetrical or symmetrical about z-axis only
- Hollow and box sections: rolled/welded, square or rectangular, doubly symmetrical
- Solid sections: round and flat bars
- Pipes
- Angles: rolled/welded single sections with equal or unequal legs
- T sections: rolled/welded, symmetrical about z-axis
- Channels: rolled/welded, symmetrical about y-axis

It is also possible to design other cross-sections of the RSTAB library or SHAPE-THIN which are labeled as "General". For those, some specific features of design are not available, however. SHAPE-THIN sections must have straight elements exclusively in order to be designed.



General cross-sections (shaded)

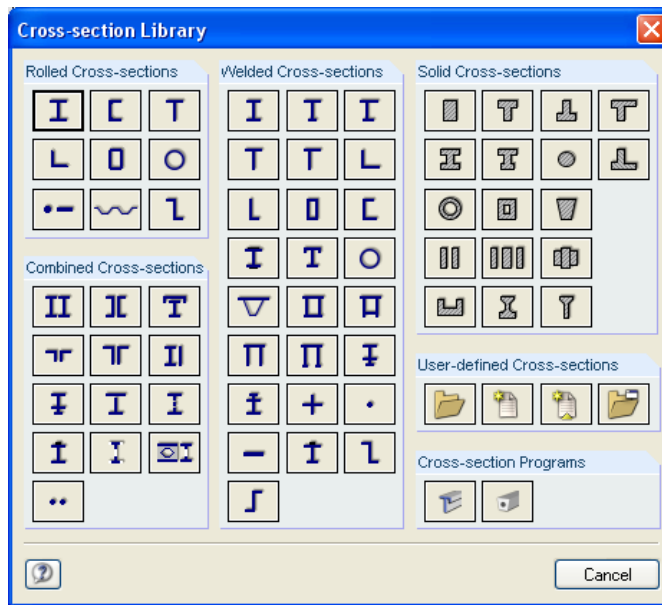

Figure 2.8: Cross-Section Library

Tapered Member



It is not possible to design tapered members in ALUMINIUM. This type of combined cross-sections is not supported. There will be error 1021) after the calculation.

Info about Cross-Section



There are different display options for stress points and c/t cross-section parts: Select the cross-section in table 1.3 and open the following dialog box by clicking the [Info] button.

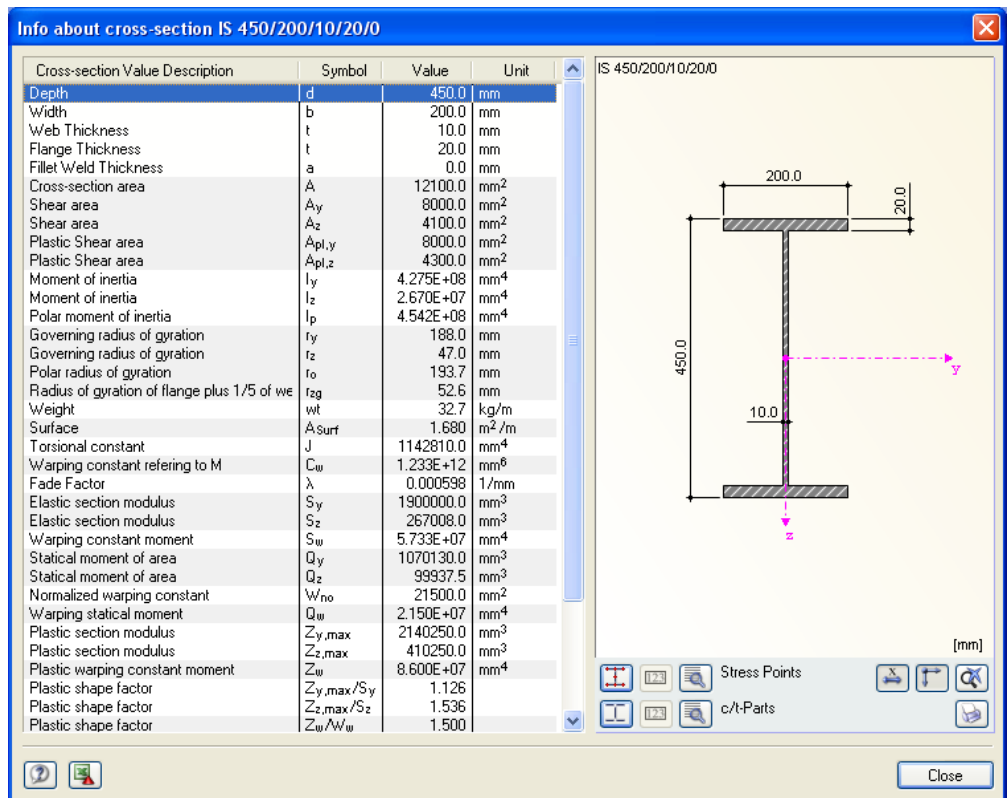

Figure 2.9: Dialog box Info about cross-section

The currently selected cross-section is displayed in the right part of the dialog box. The various buttons below have the following functions:







Button	Function
	The stress points are switched on and off.
	The cross-section parts (c/t) are switched on and off.
	The numbering of stress points, resp. of cross-section parts (c/t) is switched on and off.
	The details of stress points, resp. of cross-section parts (c/t) are displayed.
	The dimensioning of the cross-section is switched on and off.
	The principal axes of the cross-section are switched on and off.
	The overall view of the cross-section is restored.

Table. 2.1: Buttons for Cross-Section Graphics

Max. Design Ratio

This column is only displayed after the calculation. Due to those values, you can decide whether to carry out an optimization. It is apparent from the design ratios and colored relation scales which cross-sections have a low utilization and therefore are oversized, resp. which sections are overstrained and too weak.

Optimize

Every cross-section of the library can be optimized. During the optimization process, the cross-section within the same table of cross-sections is determined on the basis of the internal forces from RSTAB which fulfills best the maximum design ratio.

The maximum allowable design ratio for the optimization is controlled in the *Details* dialog box (see Figure 3.4, page 31). Further information on the optimization of cross-sections can be found in chapter 7.2 on page 52.



Remark

In this column, the references to footnotes (below the list of cross-sections) are shown.



If the message *Incorrect cross-section data!* is shown, then this is due to a cross-section that is not contained in the cross-section library. It may be a user-defined cross-section or a section that was not calculated in the module SHAPE-THIN. Via the [...] button in column B *Cross-section Description*, you can set a cross-section that is suitable for the design (see Figure 2.8).



There are several *Welded Cross-sections* in the section library. Those are parameterized sections that are usually combined by welding sheets in steelwork. Please note that the design of welds (effect of HAZ) is not implemented in the current ALUMINIUM program version.

2.4 Lateral Intermediate Supports

In this table, lateral intermediate supports on members can be defined. The program always assumes these supports as perpendicular to the minor axis z (see Figure 2.9) of the cross-section. Hence, it is possible to change the effective lengths of the member that are important for the design of buckling and lateral torsional buckling.



Lateral intermediate supports are always considered as forked supports for the design.

Member No.	Lateral Supports	Length L [m]	Number	x1	x2	x3	x4	x5	x6	x7	x8	x9
1	<input checked="" type="checkbox"/>	3,000	2	0.333	0.667							
2	<input type="checkbox"/>	3,000										
3	<input checked="" type="checkbox"/>	5,000	3	0.250	0.500	0.750						
4	<input type="checkbox"/>	5,000										
5	<input checked="" type="checkbox"/>	3,000	4	0.200	0.400	0.600	0.800					
6	<input type="checkbox"/>	3,000										
7	<input type="checkbox"/>	5,000										

Relatively (0 ... 1)

Settings for Member No. 1

Cross-section	15 - IS 250/250/10/15/0
Lateral Supports Existing	<input checked="" type="checkbox"/>
Member Length	L 3,000 m
Number of Lateral Intermediate Supports	n 2
Position of Lateral Support No. 1	x1 0.333
Position of Lateral Support No. 2	x2 0.667

Set Inputs for Members No.: []

Buttons: Calculation, Details..., Nat. Annex..., Graphic, OK, Cancel

Figure 2.10: Table 1.4 Lateral Intermediate Supports

In the upper part of this table, up to nine lateral intermediate supports can be created per member. The lower part of the table displays the summary of the entered data for the member that is selected in the upper table.

Relatively (0 ... 1)

Lateral intermediate supports can be defined either by directly entering the distances or by specifying the support locations *Relatively*. For the latter, it is necessary to tick the associated check box below the list. The relative distances of the supports are then calculated from the member lengths.

If the *Member-like Input* (see dialog box *Details, Stability* tab as displayed in Figure 3.2, page 28) is used for straight sets of members, lateral supports can be applied to the intermediate nodes of each set of members. If not, it is not possible to place lateral supports directly in nodes.

2.5 Effective Lengths - Members

The table 1.5 consists of two parts so that a good overview of the data is given. In the upper table, the buckling length coefficients $k_{cr,y}$ and $k_{cr,z}$, the effective lengths $L_{cr,y}$ and $L_{cr,z}$, the lateral-torsional buckling coefficients k_z and k_w and the effective lengths L_w and L_T are summarized for every member. In the lower part of this table, detailed information on the member that is selected in the upper table is displayed.

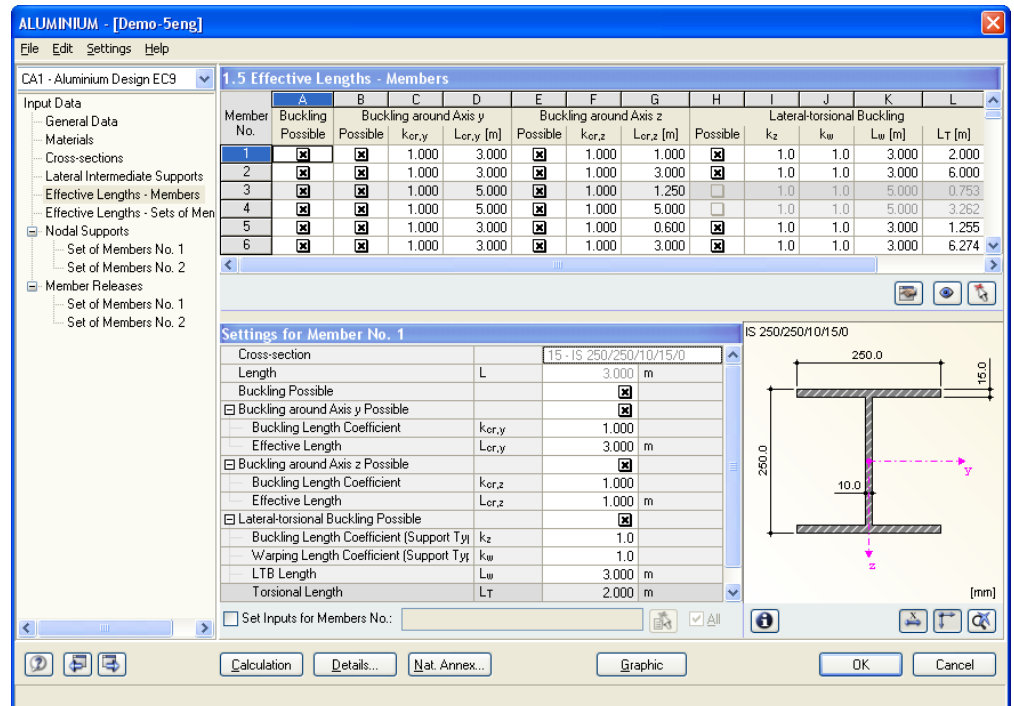

The screenshot shows the 'ALUMINIUM - [Demo-5eng]' software window. The main table, titled '1.5 Effective Lengths - Members', lists six members with their buckling and lateral-torsional buckling parameters. The 'Settings for Member No. 1' dialog box is open, showing detailed parameters for member 1, including cross-section, length, and various buckling coefficients and lengths. A diagram of an I-beam cross-section is also visible on the right side of the settings dialog.

Member No.	Buckling Possible	Buckling around Axis y		Buckling around Axis z			Lateral-torsional Buckling					
		Possible	$k_{cr,y}$	$L_{cr,y}$ [m]	Possible	$k_{cr,z}$	$L_{cr,z}$ [m]	Possible	k_z	k_w	L_w [m]	L_T [m]
1	<input checked="" type="checkbox"/>	<input checked="" type="checkbox"/>	1.000	3.000	<input checked="" type="checkbox"/>	1.000	1.000	<input checked="" type="checkbox"/>	1.0	1.0	3.000	2.000
2	<input checked="" type="checkbox"/>	<input checked="" type="checkbox"/>	1.000	3.000	<input checked="" type="checkbox"/>	1.000	3.000	<input checked="" type="checkbox"/>	1.0	1.0	3.000	6.000
3	<input checked="" type="checkbox"/>	<input checked="" type="checkbox"/>	1.000	5.000	<input checked="" type="checkbox"/>	1.000	1.250	<input type="checkbox"/>	1.0	1.0	5.000	0.753
4	<input checked="" type="checkbox"/>	<input checked="" type="checkbox"/>	1.000	5.000	<input checked="" type="checkbox"/>	1.000	5.000	<input type="checkbox"/>	1.0	1.0	5.000	3.262
5	<input checked="" type="checkbox"/>	<input checked="" type="checkbox"/>	1.000	3.000	<input checked="" type="checkbox"/>	1.000	0.600	<input checked="" type="checkbox"/>	1.0	1.0	3.000	1.255
6	<input checked="" type="checkbox"/>	<input checked="" type="checkbox"/>	1.000	3.000	<input checked="" type="checkbox"/>	1.000	3.000	<input checked="" type="checkbox"/>	1.0	1.0	3.000	6.274

Figure 2.11: Table 1.5 Effective Lengths - Members

The effective lengths for the buckling about the minor principal axis are automatically aligned with the input in the previous table 1.4. If a member is divided into different lengths by lateral intermediate supports, then no values are displayed in the corresponding columns G, K and L of the table 1.5.

It is possible to change the buckling length coefficients both in the summary table in the upper part and in the detailed settings in the lower part. The data of the corresponding part of this table is then updated automatically. The buckling length of a member can also be defined graphically by using the function [Pick].

The tree structure in the lower part of the *Settings for Member* table contains the following parameters:

- *Cross-section*
- *Length* (actual length of the member)
- *Buckling Possible* (cf. column A)
- *Buckling around Axis y* (buckling lengths, cf. columns B to D)
- *Buckling around Axis z* (buckling lengths, cf. columns E to G)
- *Lateral-torsional Buckling Possible* (lateral-torsional buckling length coefficient and lengths, cf. columns H to L)

It is also possible to modify the *Buckling Length Coefficients* in the relevant directions and decide whether the buckling design is to be executed. If the buckling length coefficient is changed, the respective effective member length is modified automatically.

If the option *Lateral-torsional Buckling Possible* is unchecked, there is no design of lateral torsional buckling due to bending about the major axis. Torsional buckling and torsional-flexural buckling due to axial compression are automatically disabled, too.

Buckling Possible

For the stability design of the buckling and lateral buckling, it is necessary for the member to transfer compression forces. Members that cannot transfer compression forces due to their definitions (e.g. tension members, elastic foundations, rigid couplings) are a priori excluded from the stability design in ALUMINIUM. Those lines are grayed out and a corresponding comment is displayed in the column *Comment*.

The column *Buckling Possible* enables you to classify specific members as compression ones or, alternatively, to exclude them from the design. Hence, the check boxes in column A and also in table *Settings for Member No.* control whether the input options for the buckling length parameters are accessible for a member.

Buckling around Axis y / Axis z

The columns *Possible* control if a member is to be designed for buckling around its axes y and/or z. The axis y represents the "major" principal member axis, the axis z the "minor" principal member axis. The buckling length coefficients (effective length factors) $k_{cr,y}$ and $k_{cr,z}$ can be freely chosen for the buckling around the major and minor axes.

The orientation of the member axes can be checked in the cross-section graphics of the table 1.3 *Cross-Sections* (see Figure 2.7). In the RSTAB work window which can be opened any time via the [Graphic] button, you can display the local member axes from the *Display* navigator.

Graphic

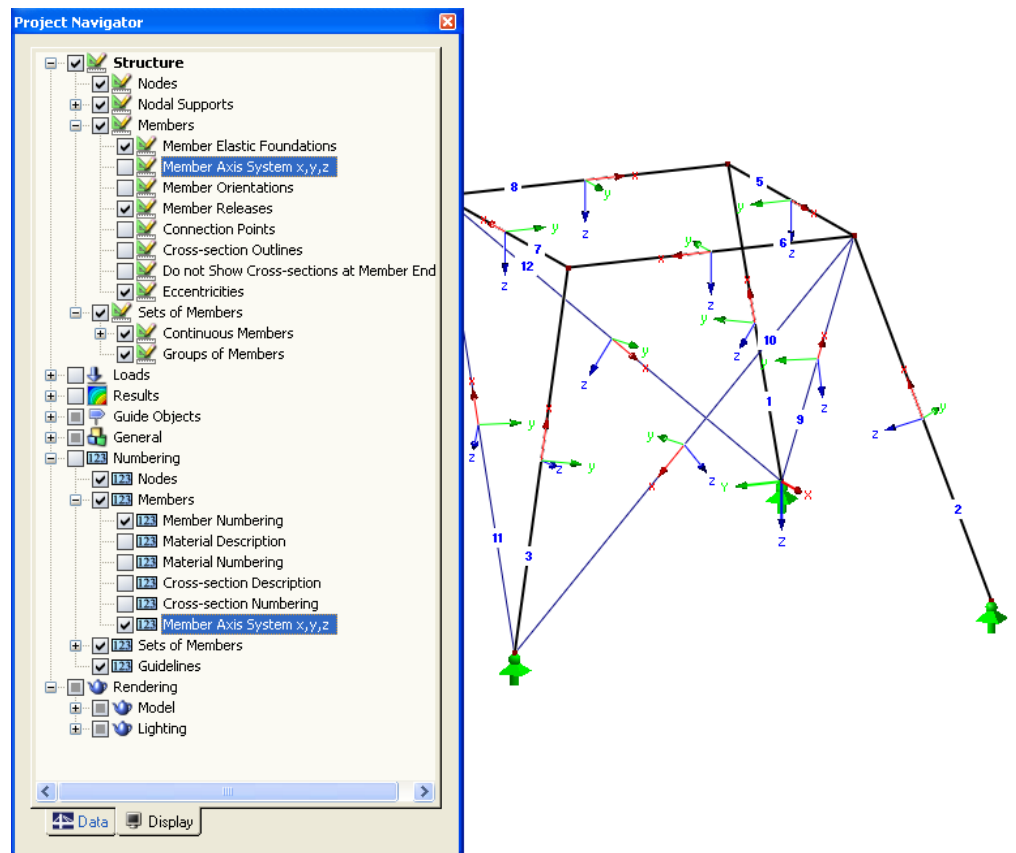

Figure 2.12: Displaying the local member axes in the *Display* Navigator of RSTAB

If buckling is possible around one or both member axes, the precise values can be entered in columns C and D respectively F and G or in table *Settings for Member No.* below.

If you define the buckling length coefficient k_{cr} the buckling length L_{cr} is determined by multiplying the member length L with this buckling length coefficient. The input fields are interactive.



Via the [...] button at the end of the L_{cr} input fields, you can select two nodes in the RSTAB work window graphically. Their distance then defines the buckling length.



The effective length factors of the members can also be defined in a special dialog box which is called by the button [Select Effective Length Factor] below the upper table.

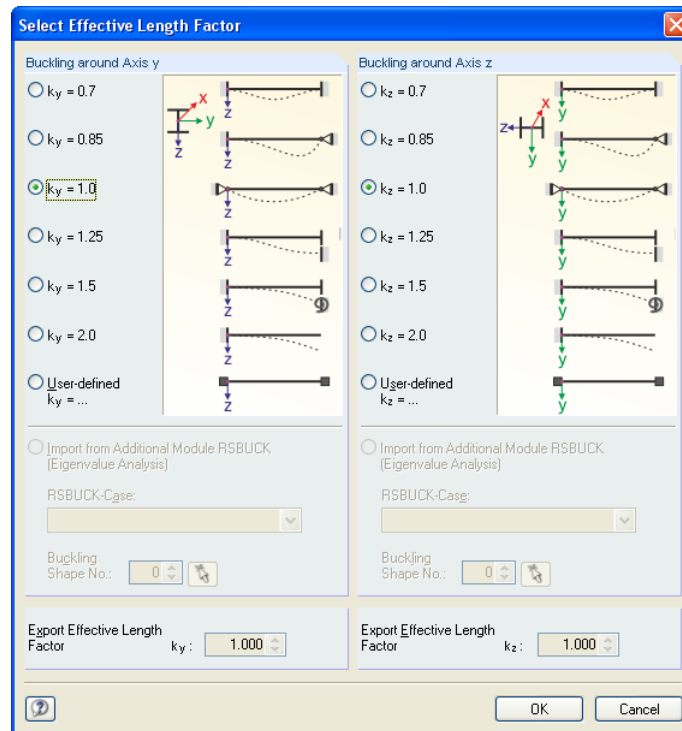

Figure 2.13: Dialog box *Select Effective Length Factor*

The predefined values of effective length factors $k_{cr,y}$ and $k_{cr,z}$ correspond to the following definitions in [1], Table 6.8:

- $k = 0.70$ held in position at both ends + restrained in direction at both ends
- $k = 0.85$ held in position at both ends + restrained in direction at one end
- $k = 1.00$ held in position at both ends + not restrained in direction at either end
- $k = 1.25$ held in position at one end + restrained in direction at both ends
- $k = 1.50$ held in position and restrained in direction at one end + not held in position and partially restrained in direction at other end
- $k = 2.00$ held in position and restrained in direction at one end + not held in position and not restrained in direction at other end

The effective length factors can be also imported from the add-on module RSBUCK.

Lateral-Torsional Buckling

Column H controls for which members a lateral torsional buckling design is to be carried out.

To calculate M_{cr} by means of the eigenvalue method, it is necessary to create an internal member model with four degrees of freedom. The coefficients k_z and k_w (see below) convey the degrees of freedom on the supports of this internal model:



- $k_z = 1.0$ forked support at both beam ends
- $k_z = 0.7le$ restrained at left end and forked support at right end
- $k_z = 0.7ri$ restrained at right end and forked support at left end
- $k_z = 0.5$ restrained at both beam ends
- $k_z = 2.0le$ restrained at left end and free right end
- $k_z = 2.0ri$ restrained at right end and free left end

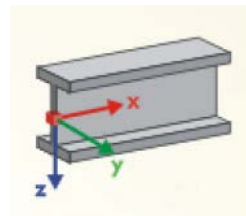

Figure 2.14: Axis for k_z and k_w

The forked support with $k_z = 1.0$ corresponds to a rigid support in the y-direction and a restriction of rotation around the x-axis (longitudinal axis) of the member. If there is a full restraint, the rotation around the z-axis is restricted additionally. The abbreviations *le* and *ri* represent the left and right sides. "Left" is always related to the support conditions at the member start.



Regarding the fact that the coefficients k_z and k_w are always related to the member start and end, intermediate supports have to be handled with care. Those supports split up the member into segments for the design. Thus, intermediate supports are not applicable for cantilever beams: They would imply statically underdetermined segments with fork-type supports on only one side each.

By the factor k_w , the fourth degree of freedom on the support is defined. It has to be decided whether warping is possible for the cross-section. Regarding the fact that the internal member model uses only four degrees of freedom, no more degrees of freedom (displacements in directions x and z) have to be defined.

The coefficient k_w which you can define in column J controls the torsional and torsional-flexural buckling design. It has an effect on the calculation of the elastic critical moment at lateral buckling M_{cr} . The list contains the following options:

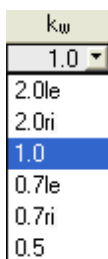

- $k_w = 1.0$ support without warping restriction at both beam ends
- $k_w = 0.7le$ restrained at left end and forked support at right end
- $k_w = 0.7ri$ restrained at right end and forked support at left end
- $k_w = 0.5$ support with warping restriction at both beam ends
- $k_w = 0.7le$ restrained at left end and free right end
- $k_w = 0.7ri$ restrained at right end and free left end

The values in column K represent the lengths between the points that are laterally restrained. L_w is used to determine the critical moments M_{cr} .

The torsional lengths L_T in column L are required to calculate the torsional forces $N_{cr,T}$ and the torsional-flexural buckling critical forces $N_{cr,TF}$.



The check box *Set Inputs for Members No.* is located beneath the *Settings* table. If you tick this box, the data entered consequently will become valid for selected resp. *All* members. You can select the members graphically via [Pick] or enter the numbers manually. This function can be used to assign identical boundary conditions to several members. Please notice that this function must be activated prior to entering data. If you define the data and choose this option later, the data will not be re-assigned.

Comment

You can insert specific remarks in the last column for every member, e.g. to explain the defined buckling criteria of a member.

2.6 Effective Lengths - Sets of Members

The input table 1.6 controls the effective lengths for sets of members. It is only available if one or more sets of members have been selected in table 1.1 *General Data*.

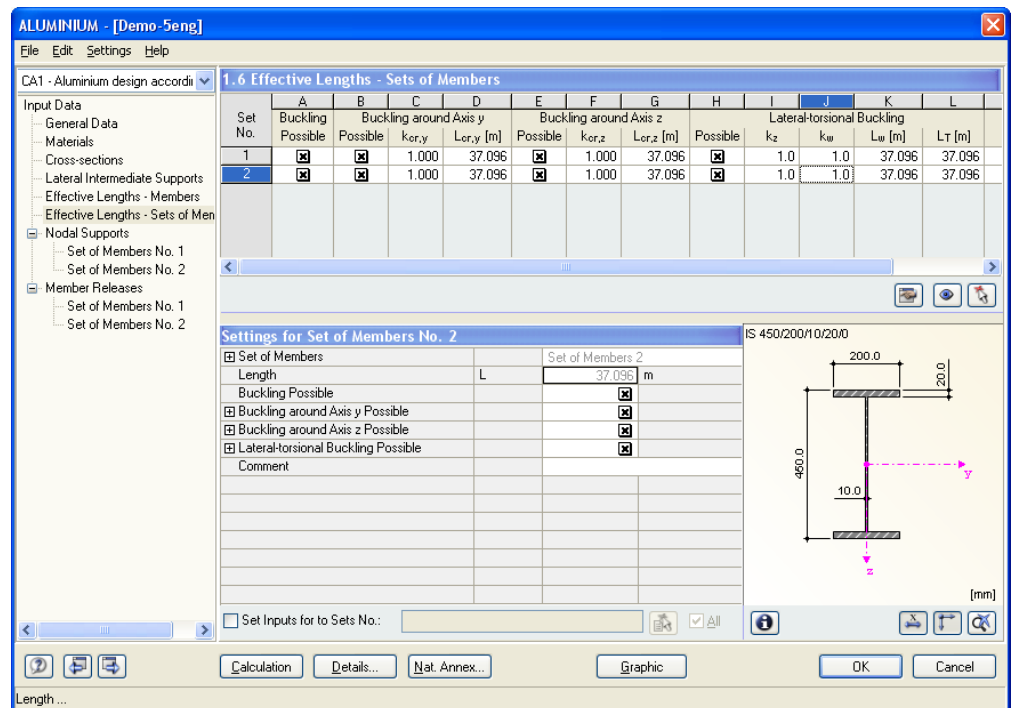

Figure 2.15: Table 1.6 *Effective Lengths - Set of Members*

This table is very similar to the previous table 1.5. With regard to the effective lengths for buckling around the major and minor axes of the cross-sections, it is identical to table 1.5.

There are differences, however, with regard to the parameters k_z and k_w for torsional and lateral-torsional buckling. These are used only for straight sets of members if the *Member-like Input* option is checked in the dialog box *Details, Stability* tab (cf. Figure 3.2, page 28). Otherwise, the parameters can be defined by specific boundary conditions in tables 1.7 and 1.8 (cf. chapters 2.7 and 2.8) for sets of members not covered by the *Member-like Input*.

If the *Member-like Input* (cf. Figure 3.2, page 28) is enabled and if the set of members is straight, tables 1.7 and 1.8 are not displayed. The lateral supports can be then defined by intermediate nodes in table 1.4.



Do not use the determination of x_s acc. to [1], eq. (6.71) for the lateral-torsional stability design of non-straight sets of members: The bending moments at the start and the end of a set of members can imply misleading values of x_s , ω_x and ω_{xLT} and, thus, deviant results.

2.7 Nodal Supports - Sets of Members

If the *Member-like Input* is enabled (cf. Figure 3.2, page 28) and if the set of members is straight, this table is not displayed. The lateral supports can be defined by intermediate nodes in table 1.4.



The stability design of sets of members is based on the loads and boundary conditions of the selected sets of members. The value of the bifurcation factor α_{cr} has to be determined for the entire set of members in order to obtain critical moment M_{cr} . The calculation of α_{cr} also depends on the settings in the *Details* dialog box (cf. chapter 3.1).

To determine α_{cr} , a planar member structure with four degrees of freedom per node is created. The specific support conditions are defined in table 1.7. This table is only available if you have selected one or more sets of members in table 1.1 *General Data*.

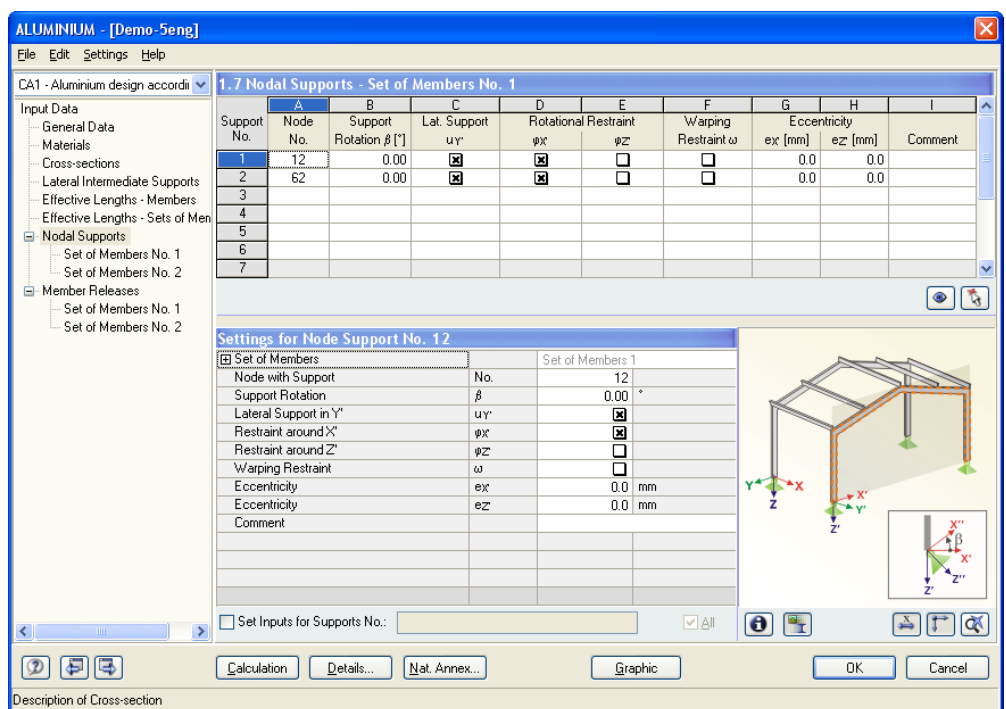

Figure 2.16: Table 1.7 Nodal Supports - Set of Members



To define the nodal supports, the orientation of the axes within a set of members is important. The program internally checks the location of the relevant nodes and then determines the axis system for the nodal supports that are to be defined in table 1.7 (cf. Figure 2.17 to Figure 2.20).

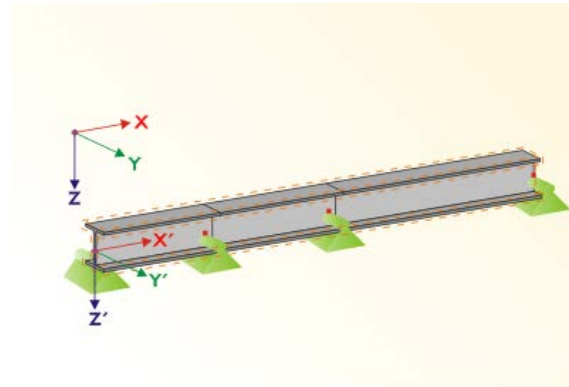

Figure 2.17: Auxiliary coordinate system for nodal supports – straight set of members

If all the members within the set of members lie on a straight line (Figure 2.17), the local coordinate system of the first member is applied for the entire set of members.

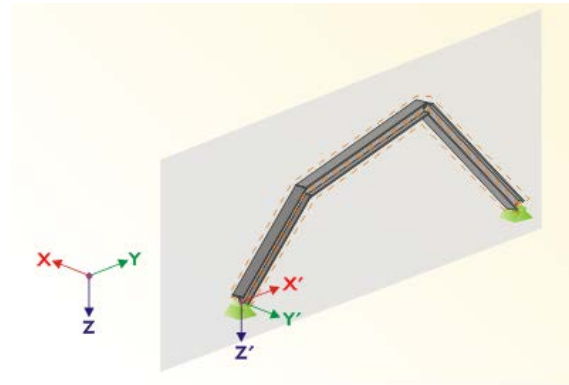

Figure 2.18: Auxiliary coordinate system for nodal supports – set of members in vertical plane

Even if the members within a set do not lie on a straight line, they still must lie in a plane. We can see a vertical plane in Figure 2.18. In this case the axis X' is horizontal and in the plane direction. The axis Y' is also horizontal, but perpendicular to the axis X' . The axis Z' points vertically downwards.

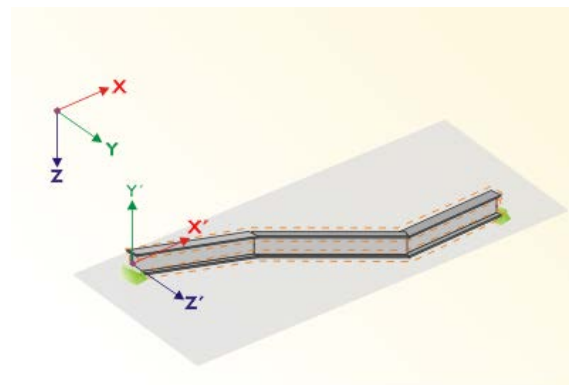

Figure 2.19: Auxiliary coordinate system for nodal supports – set of members in horizontal plane

If the members are located in a horizontal plane (Figure 2.19), the axis X' is parallel with the axis X of the global coordinate system. The axis Y' then points in the opposite direction of the global axis Z . The axis Z' is parallel with the axis Y of the global coordinate system.

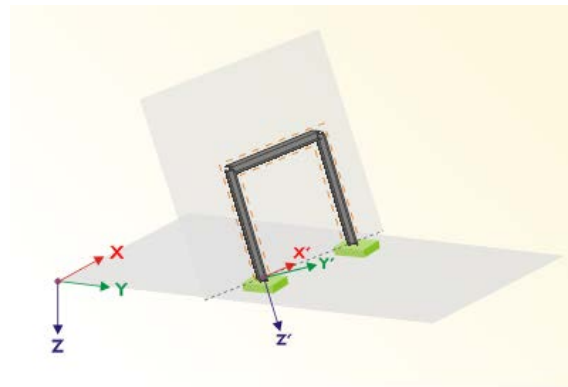

Figure 2.20: Auxiliary coordinate system for nodal supports – set of members in oblique plane

Figure 2.20 shows the most general case. The members within a set of members do not lie on a straight line but are located in an oblique plane. The orientation of the axis X' is then determined by the intersection between the oblique and the horizontal plane. The axis Y' is perpendicular to the axis X' and is also perpendicular to the oblique plane. The axis Z' is perpendicular to the axes X' and Y' .

2.8 Member Releases - Sets of Members

This table is only available if one or more sets of members have been selected in table 1.1 *General Data*. If any member in a given set is not able to transfer internal forces corresponding to the degrees of freedom restricted in the table 1.7, then nodal releases can be inserted to a set of members in the table 1.8. There is also possibility to exactly define on which *Member Side* the release is to act or to place the release at both sides.

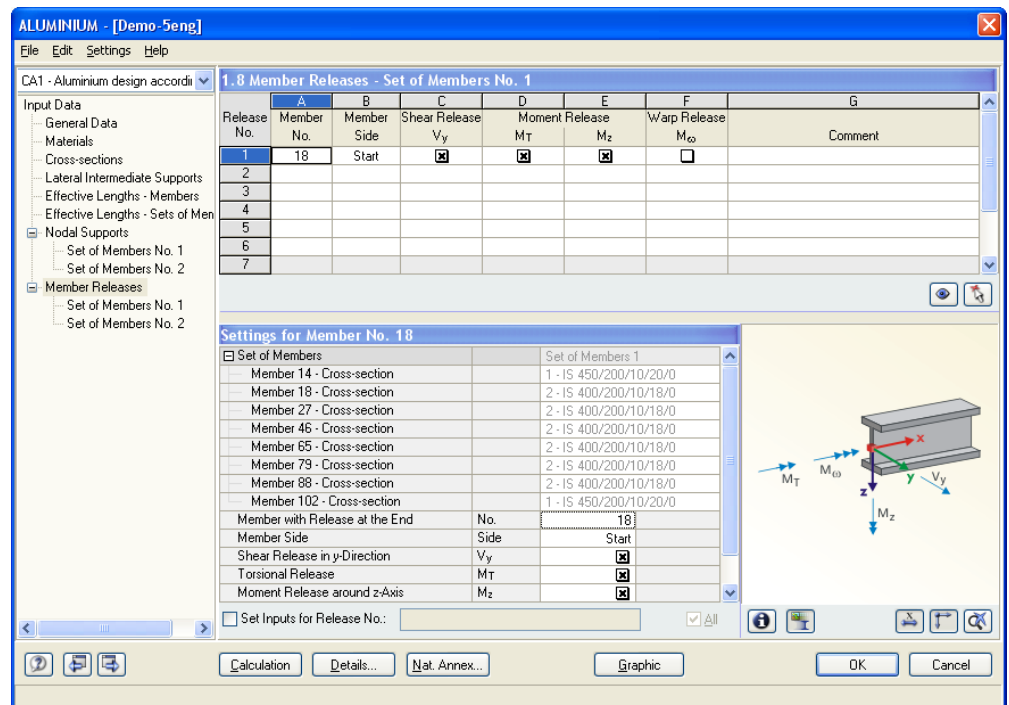
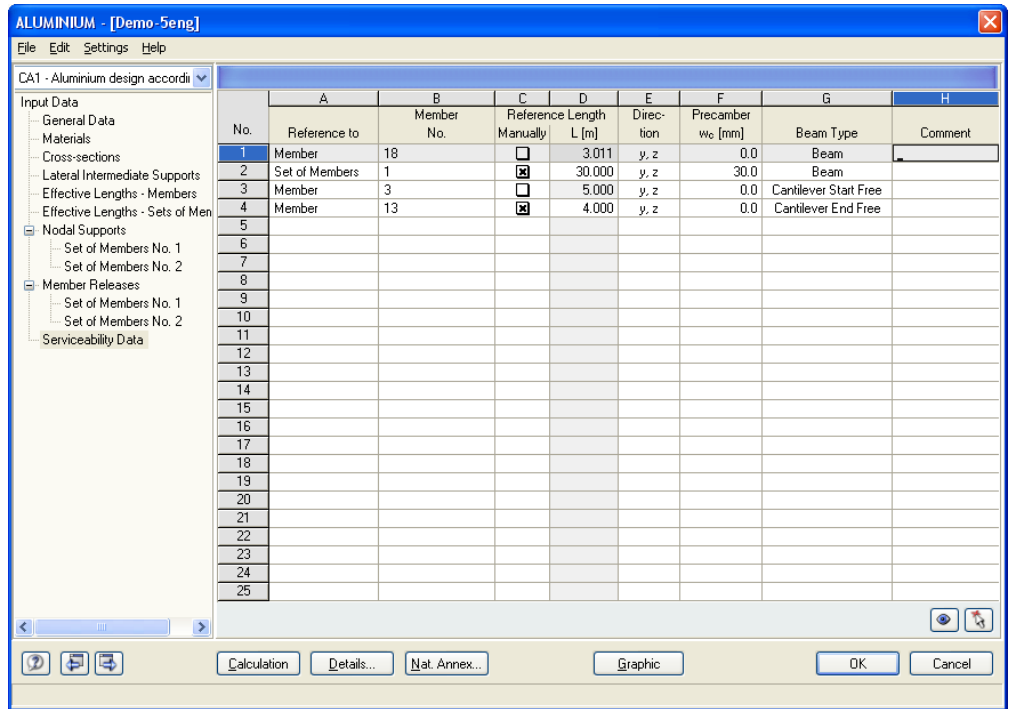

Figure 2.21: Table 1.8 Member Releases - Set of Members

If the *Member-like Input* is enabled (cf. Figure 3.2, page 28) and if the set of members is straight, this table is not displayed. The lateral supports can be defined by intermediate nodes in table 1.4.

2.9 Serviceability Data

The final input table includes different possibilities for the serviceability design. It is only displayed if the serviceability limit state design has been selected in table 1.1 *General Data* (cf. Figure 2.3).



No.	A	B	C	D	E	F	G	H
	Reference to	Member No.	Reference Length Manually	Reference Length L [m]	Direction	Precamber w_c [mm]	Beam Type	Comment
1	Member	18	<input type="checkbox"/>	3.011	y, z	0.0	Beam	
2	Set of Members	1	<input checked="" type="checkbox"/>	30.000	y, z	30.0	Beam	
3	Member	3	<input type="checkbox"/>	5.000	y, z	0.0	Cantilever Start Free	
4	Member	13	<input checked="" type="checkbox"/>	4.000	y, z	0.0	Cantilever End Free	
5								
6								
7								
8								
9								
10								
11								
12								
13								
14								
15								
16								
17								
18								
19								
20								
21								
22								
23								
24								
25								

Figure 2.22: Table 1.9: *Serviceability Data*

In column A, you can refer the deformation to individual members, list of members or sets of members.

In column B, the relevant members or sets of members can be selected graphically by using the function [Pick]. The reference lengths L in column D are then filled automatically. The *Reference Length* is set as the length of the member or the entire length of the set resp. list of members. It can be changed *Manually* by using the corresponding check box in column C and setting the value in column D.

In column E, you specify the governing *Direction* for the serviceability design. Column F controls whether *Precamber* w_c is to be taken into account as well.

For a correct determination of the serviceability limit states, the *Beam Type* (beam or cantilever) is very important. It can be entered in column G.

The settings in the dialog box *Details, Serviceability* tab controls whether the deformations are referred to the undeformed initial model or to the shifted ends of the members or sets of members (cf. Figure 3.3).

[Details...](#)

3. Calculation

3.1 Details

Calculation

Details...

The design is carried out with the internal forces calculated in the RSTAB program. Before the [Calculation], you should check the detailed settings for the design. The corresponding dialog box can be opened from every input or output table by clicking the [Details] button.

The *Details* dialog box consists of four tabs: *Ultimate Limit State*, *Stability*, *Serviceability* and *Other*.

3.1.1 Ultimate Limit State

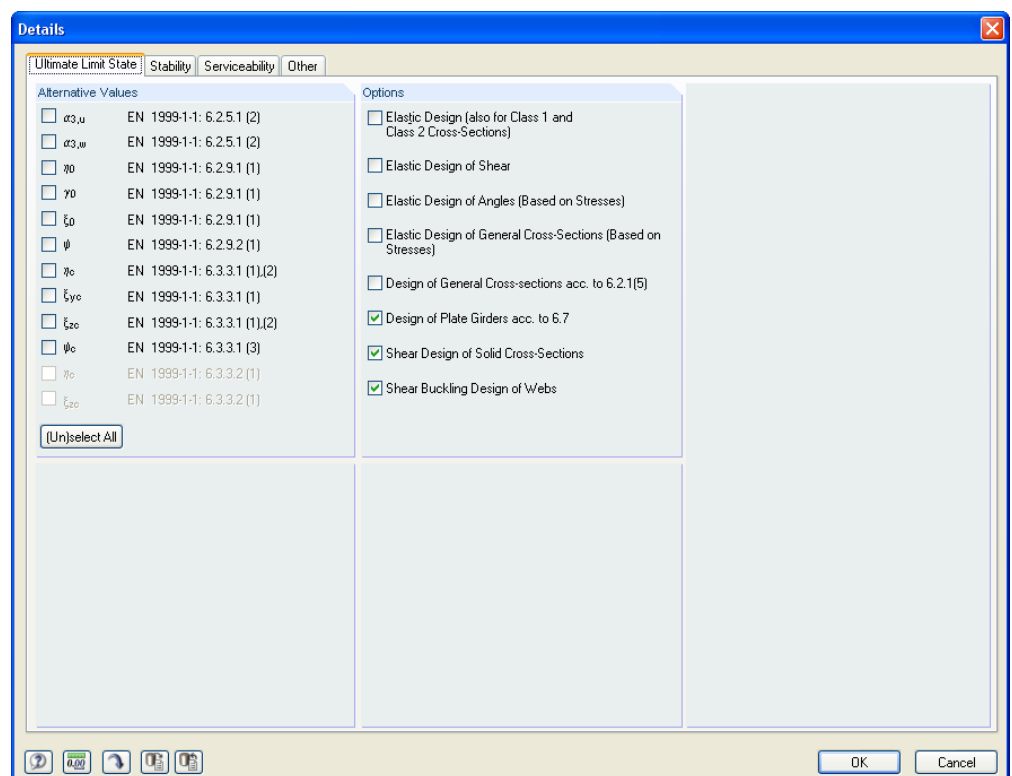

Figure 3.1: Dialog box *Details*, *Ultimate Limit State* tab

Alternative Values

This dialog section contains a list of parameters that allow for an alternative calculation of values according to EN 1999-1-1. If a box is not checked, the default value will be used. The relevant code clauses are stated for each parameter.

(Un)select All

It is possible to choose the default or alternative calculation for each value separately or to use the button [(Un)select All] to set or to remove the check boxes of the whole list.

Options

By default, there is a plastic analysis or elastic analysis in ALUMINIUM – dependent on the class of the cross-section. If required, only the *Elastic Design* can be activated. Then for all cross-sections classified as 1 or 2 the elastic parameters (as class 3) are used for the design.

The *Elastic Design of Shear* can be used if the shear design is to be based on shear stress instead of plastic shear resistance (default).

The *Elastic Design of Angles (Based on Stresses)* can be applied if the design of angles according to [1], clauses 6.2.5 to 6.2.10 is to be based on stresses instead of resistance values (default). If this option is checked, the factors ξ_{50} , η_0 , γ_0 and ω_0 will be set to 1.00.

Optionally, the *Elastic Design of General Cross-sections (Based on Stresses)* can be performed according to [1], clauses 6.2.5 to 6.2.10 for "general" types such as some sections of the RSTAB library or SHAPE-THIN sections. The design is then based on stresses instead of resistance values (default). Additionally, the *Design of General Cross-sections acc. to 6.2.1(5)* can be used. This means that the VON MISES yield stresses are calculated in each stress point. The highest ratio according to [1], eq. (6.15) is then used to determine the critical stress point and the final design ratio of each x-location of the member. The parameter C can be set in the *National Annex* dialog box (see chapter 2.1.3, page 11).

The *Design of Plate Girders acc. to 6.7* can be used for cross-sections which fulfill plate girder criteria and are not marked as "general" sections. ALUMINIUM does not support the design of transverse or longitudinal stiffeners, however.

The *Shear Design of Solid Cross-sections* makes it possible to check shear and bending of massive sections. If this option is not active, bending moments, torsional moment and shear forces are neglected even if they were calculated in RSTAB.

Shear Buckling Design of Webs implies that the design is to be performed according to [1], clauses 6.5.5 and 6.7.4.



The partial factors γ_M of the materials are controlled in the *National Annex* dialog box (see chapter 2.1.3, page 11). Please also note that the design of welds (effect of HAZ) is not implemented in the current program version.

3.1.2 Stability

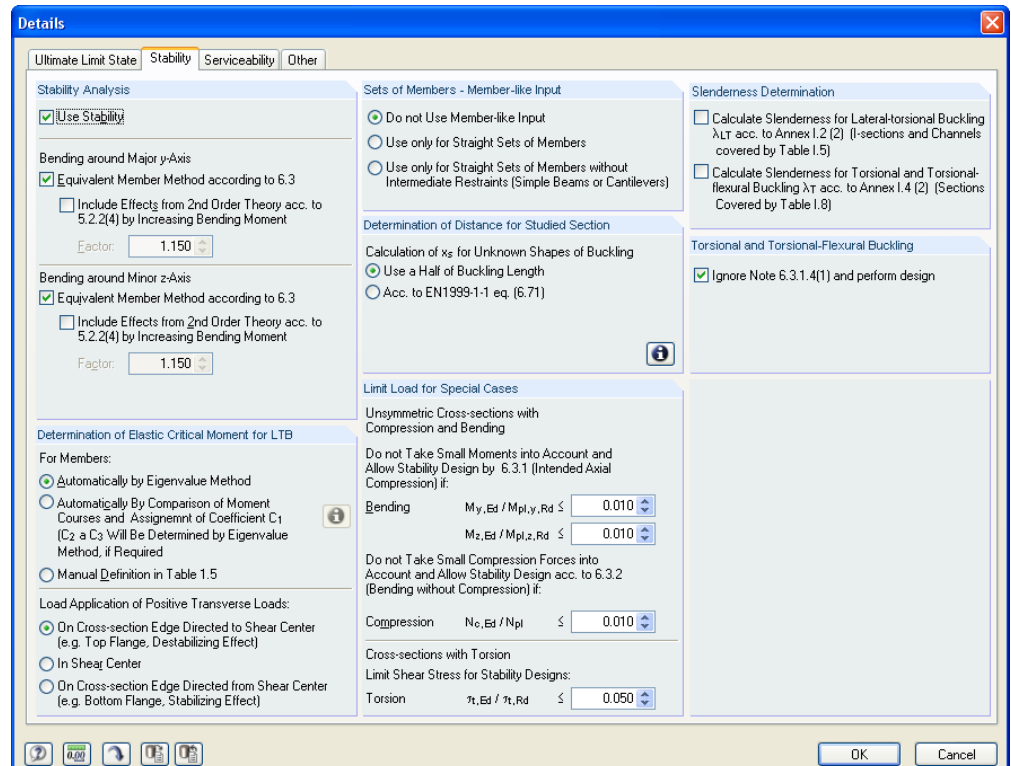

Figure 3.2: Dialog box *Details*, *Stability* tab

Stability Analysis

This section controls whether a stability analysis is to be carried out. If the check is disabled, the input tables 1.4 to 1.8 will not be active.

It can also be specified whether the stability design is to be considered for *Bending around the Major and/or Minor Axis*. The effects of the *2nd Order Theory* can be accounted for according to [1], clause 5.2.2(4) by increasing the bending moments by a specific factor. When the check is set, the enlargement factor can be entered. This factor is suited for e.g. a frame whose governing stability failure is lateral buckling. Then, the internal forces can be calculated according to a linear static analysis and then be magnified by suitable factors.

Determination of Elastic Critical Moment for LTB

By default, the elastic critical moment is calculated *Automatically by Eigenvalue Method*. In this case, an internal model of finite elements is used to determine M_{cr} with consideration of the following aspects:

- Dimensions of gross cross-section
- Load type and location of load application point
- Real distribution of moments
- Lateral forced deformations (due to support conditions)
- Real boundary conditions

The degrees of freedom of the internal member model are defined by means of the coefficients k_z and k_w (see chapter 2.5).



If the option to determine the elastic critical moment by comparing the *Moment Courses* is chosen, then the calculation of the coefficient C_1 can be controlled in a dialog box which is accessible via the [Info] button. The coefficients C_2 and C_3 are calculated automatically by the eigenvalue method.



For an unsymmetric section whose shear center has a considerable distance to the centroid in horizontal direction (axis y), a *Manual Definition in Table 1.5* of M_{cr} is recommended. This value can be determined in the FE-LTB module, for example.

The *Load Application of Positive Transverse Loads* has to be accounted for if those loads have effect on a member. Lateral loads can have stabilizing or destabilizing effects, depending on the application point. This point can be set in the final part of the dialog section.

For detailed information on the theoretical background, see [1], Annex I.

Sets of Members - Member-like Input



The stability behavior of sets of members can be analyzed according to three options. It is recommended to apply the ALUMINIUM design only for straight sets of members.

If the default *Do not use Member-like Input* is set, a general analysis based on the multiplier α_{cr} is carried out. The support conditions have to be defined in table 1.7 for all sets of members. The factors k_z and k_w from table 1.6 will not be used.

It is possible to limit the member-like input for *Use only for Straight Sets of Members* with equal cross-section parameters. The factors k_z and k_w as defined in table 1.6 are then used to determine the support conditions β , u_y , φ_x , φ_z and ω . Tables 1.7 and 1.8 will not be displayed for straight sets. This option can be used e.g. for continuous beams. Please note that the factors k_z and k_w are identical for every segment or partial member of the set.

The third option applies the member-like input only to *Straight Sets of Members without Intermediate Restraints* modeled in RSTAB. Thus, only sets of members which have RSTAB supports/restraints at their ends will be considered for the member-like input. This option can be used to design e.g. simple beams or cantilevers. The connection of transverse beams to the intermediate nodes of the set is not accounted for, however. Tables 1.7 and 1.8 will not be displayed for straight sets that have no intermediate supports.

Determination of Distance for Studied Section

The distance x_s is defined in [1], figure 6.14. It represents the distance between the studied section and a support or point of contra flexure of deflection curve for elastic buckling of axial force only. It is possible to apply *Half of Buckling Length* conservatively or to determine x_s according to [1], eq. (6.71) for members that have end moments (transverse loads are not admitted). Since the formula provides only one value for x_s , this value will be used in each section of the member.

The application of [1], eq. (6.71) is restricted to linear moment diagrams of the member. Furthermore, the right side has to return a value between -1.0 and 1.0 since the left side of the equation represents a cosine. If one of those two conditions is not fulfilled, the formula will not be applied. Instead, x_s is assumed as half of the buckling length for each section.

In the current program version, all buckling shapes are considered as unknown. The determination of x_s as for known buckling shapes, based on bending moments and rotations, is not implemented.

Limit Load for Special Cases

It is possible to neglect small moments around the major and also the minor axes in order to design unsymmetrical cross-sections of axial compression according to [1], clause 6.3.1.

In a similar way, very small axial forces can be neglected so that a bending design without compression according to [1], clause 6.3.2 is possible – by defining the limit ratio N to N_{pl} .

Systematic torsion is not accounted for in EN 1999-1-1 adequately. If torsional shear stresses exist but do not exceed the default limit of 5 %, they will be neglected for the stability design (buckling, lateral buckling).

If any of those limits is exceeded, a message is shown in the results table and the stability design is not carried out. The results of the cross-section design are nevertheless displayed.

Slenderness Determination

Annex I of EN 1999-1-1 provides alternative, simplified procedures how to calculate relative slendernesses for lateral torsional buckling (Annex I.2, clause 2) and torsional and torsional-flexural buckling (Annex I.4, clause 2). Check the appropriate option to enable an alternative calculation.



The alternative calculation of relative slenderness is never used for angles with unequal legs, double angles, cruciforms, cross-sections with fillets or bulbs and general cross-sections.

Torsional and Torsional-Flexural Buckling

Clause 6.3.1.4(1) refers to certain section types that can be neglected for torsional or flexural-torsional design: hollow sections, doubly symmetrical I-sections and sections composed of radiating outstands (angles, tees) and classified as class 1 or 2. The check box makes it possible to ignore this type of stability design for the above-mentioned sections.

3.1.3 Serviceability

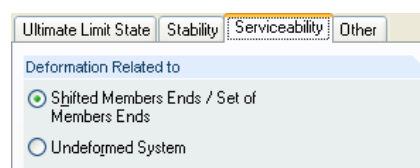

Figure 3.3: Dialog box *Details, Serviceability* tab

There are two options in the dialog section *Deformation Related to*: The selection fields control whether the maximum deformations are to be related to the undeformed, original

model or to an imaginary connecting line between the shifted start and end nodes of the member or set of members within the deformed structure.

The limit deformations can be checked and, if necessary, modified in the *National Annex* dialog box (see chapter 2.1.3, page 11).

3.1.4 Other

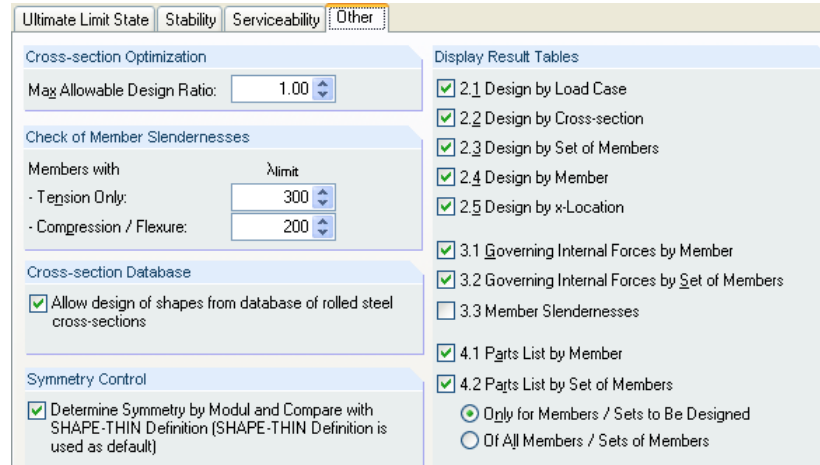

Figure 3.4: Dialog box *Details*, *Other* tab

Cross-section Optimization

Cross-section can be optimized if the *Optimize* option is chosen in table 1.3 *Cross-Sections* (see Figure 2.7, page 14). The dialog box *Details* enables you to set the maximum allowable design ratio as a limit for the optimization process.

Check of Member Slendernesses

It is possible to set user-defined slenderness ratios for members with *Tension* or *Compression / Flexure*. These maximum values are compared with the actual member slendernesses in table 3.3. This results table is available after the calculation (see chapter 4.8, page 39) when the corresponding check box is ticked in the *Display Results Tables* section to the right.

Cross-Section Database

The design of cross-sections which are primarily made of steel (rolled sections) is enabled by default. If this option is unchecked, only cross-sections of the categories *Welded*, *Solid* or *User-defined* will be designed.

Check of Symmetry

This option can be used to make sure whether the cross-section is symmetrical with regard to its principal axis system. Some SHAPE-THIN sections or general RSTAB sections may not be compatible with the design procedure settings of ALUMINIUM where the y-axis is always considered as the major and the z-axis as the minor axis. If, for example, $I_y < I_z$ or the principal axis rotation implies that the z-axis is the major axis, the ALUMINIUM results may be misleading. Therefore, this option can be used to check the symmetry of general sections, independently on the SHAPE-THIN definition. If the symmetry data obtained by both procedures are different, an error message will be displayed.

Display Results Tables

In this section, the results tables can be specified which are to be displayed, inclusive of a parts list. The results tables are described individually in chapter 4.

3.2 Start Calculation

Calculation

In all input tables of ALUMINIUM, you can start the design via the [Calculation] button.

At first, ALUMINIUM searches for results of the selected load cases, groups and combinations. If they are not found, the calculation of the governing internal forces in RSTAB is started. The calculation parameters of RSTAB are used for this analysis.

If cross-sections are to be optimized (cf. chapter 7.2, page 52), the required sections are calculated and the relevant designs are carried out.

The ALUMINIUM design can be also started from the RSTAB interface. All design cases of the add-on modules are displayed in the *To Calculate* dialog box, similarly to load cases or load groups. Open this dialog box in RSTAB via the main menu

Calculate → To Calculate.

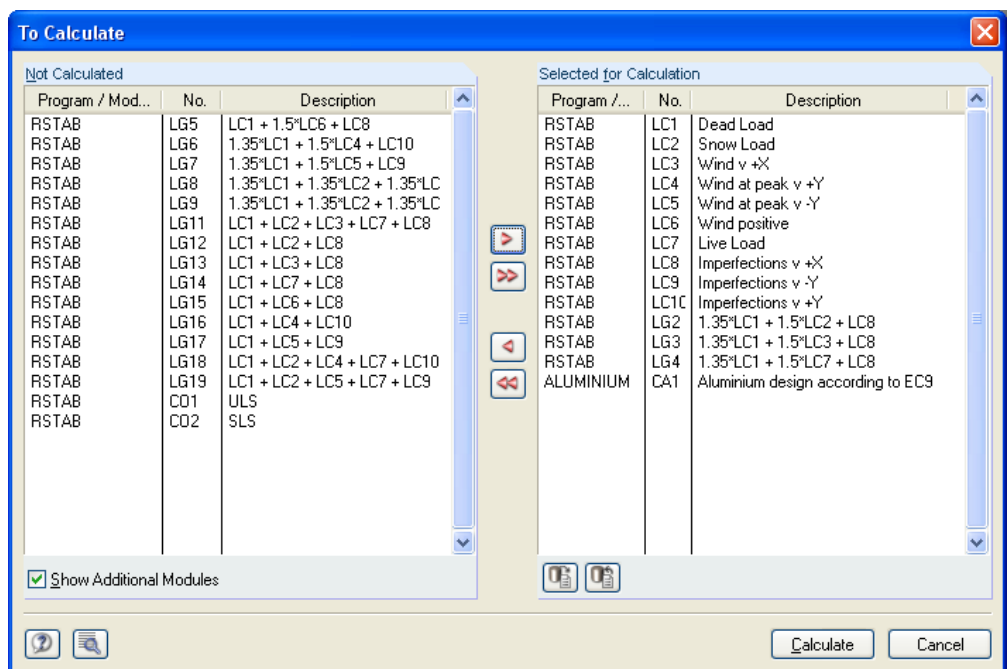

Figure 3.5: Dialog box *To Calculate*

If the design cases of ALUMINIUM are missing in the list *Not Calculated*, it is necessary to tick the check box *Show Additional Modules*.

The [▶] button transfers selected design cases to the list on the right. You can then start the calculation by the [Calculate] button.

The calculation of a specific ALUMINIUM design case can also be directly started from the toolbar. Set the relevant design case in the list and then click on the [Results on/off] button.

▶
Calculate
👁



Figure 3.6: Direct calculation of an ALUMINIUM design case in RSTAB

A dialog box appears in which you can watch the progress of the design.

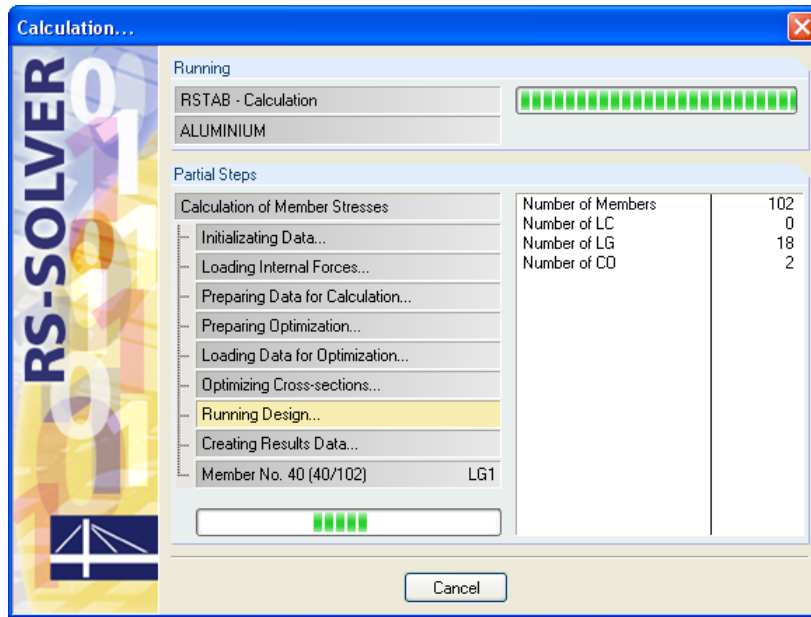

Figure 3.7: Calculation in ALUMINIUM

4. Results

Table 2.1 *Design by Load Case* is displayed immediately after the design. In the upper part of this table, a summary of all designs for every load case, load group and combination is displayed. The lower part includes all details of the material properties, design internal forces and design data of the load case which is selected in the upper part of the table.

The results tables 2.1 to 2.5 contain the detailed design summaries according to different selection criteria. Tables 3.1 and 3.2 include the governing internal forces. The parts lists are displayed in the last two tables 4.1 and 4.2.

The results tables are accessible from the navigator in ALUMINIUM. You can also switch among the tables via the buttons as seen to the left or the functional keys [F2] and [F3].

Save the results by the [OK] button and close ALUMINIUM.

In this chapter, the particular tables are described in the given order. The following chapter 5 *Evaluation of Results* from page 42 onward is devoted to the evaluation and checking of results.

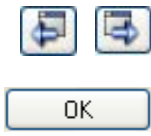

4.1 Design by Load Case

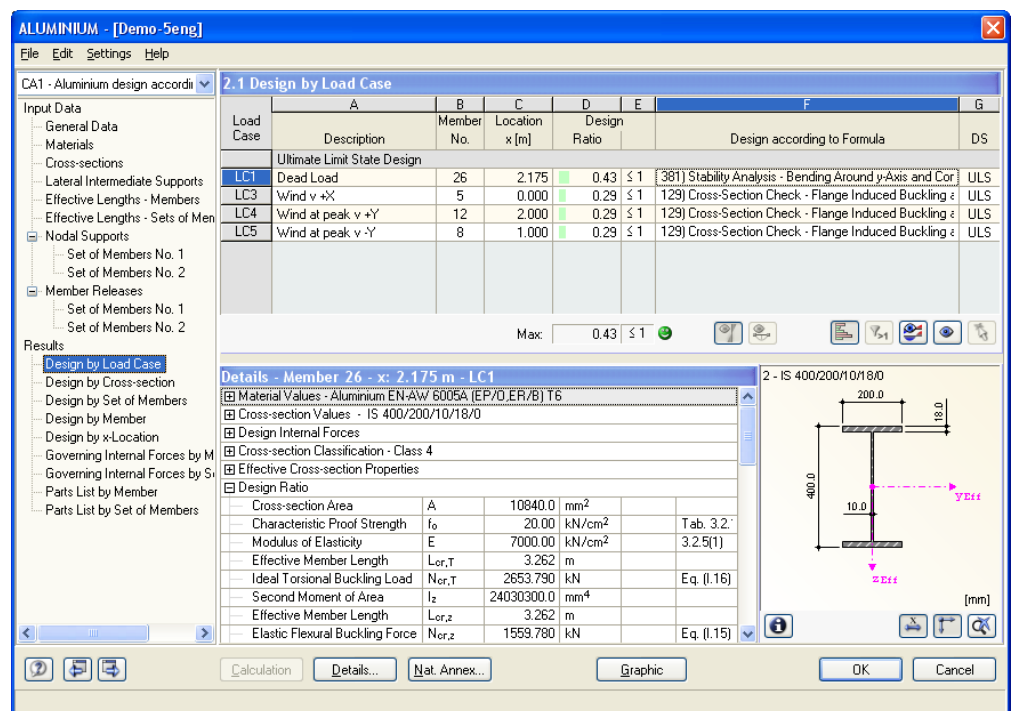

Figure 4.1: Table 2.1 *Design by Load Case*

Description

The load cases, load groups and combinations that are decisive for every relevant type of design are displayed in this column.

Member No.

The number of the member with the highest design ratio is stated for every designed load case, load group or load combination.

Location x

The location x on the member where the maximum design ratio occurs is displayed in this column. Those locations x on the member are taken into account:

- Start and end nodes
- Internal nodes according to a potential user-defined member division
- Divisions for member results according to settings in RSTAB dialog box *Calculation Parameters, Options* tab
- Extreme values of internal forces

Design Ratio

For every design type and for every load case, load group or load combination, the design quotients according to the standard are displayed in this column.

The colored bars illustrate the utilizations of every load case.

Design according to Formula

In this column, the equations that were followed in the design are displayed.

DS

The *Design Situations* which are relevant for the design are stated in the last column: *ULS* (Ultimate Limit State) or one of the three SLS design situations (*CH, FR, QP*) as specified in table 1.1 General Data (cf. Figure 2.3, page 10).

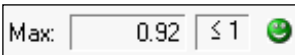

4.2 Design by Cross-Section

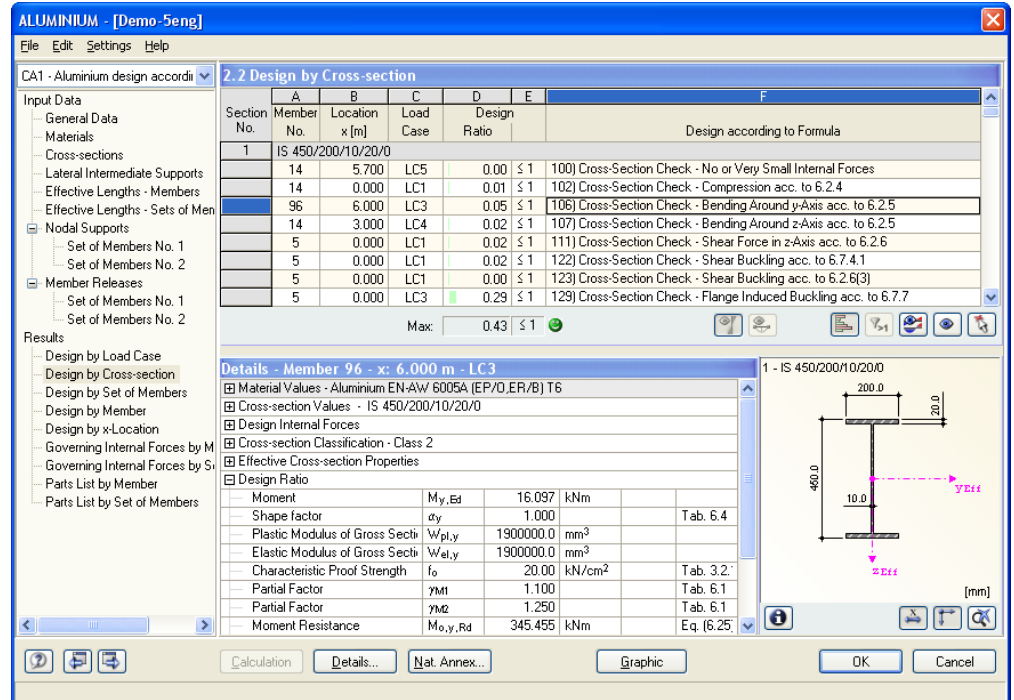

Figure 4.2: Table 2.2 *Design by Cross-section*

In this table, the maximum design ratios for all designed members and for all designed load cases, load groups and combinations. The results are listed according to cross-sections.

4.3 Design by Set of Members

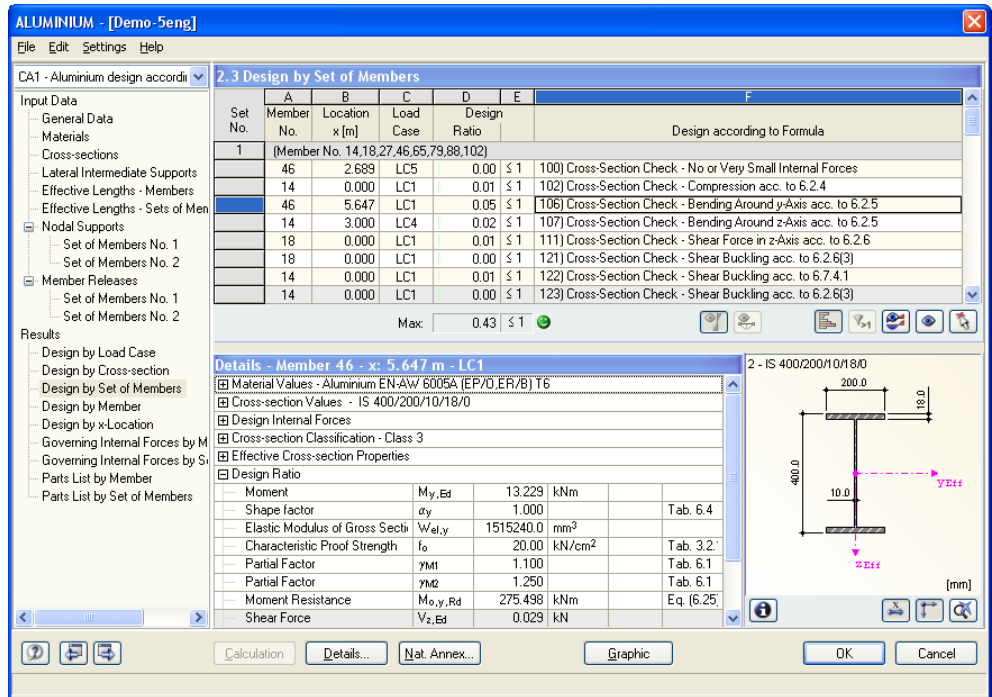

Figure 4.3: Table 2.3 Design by Set of Members

This table is displayed if at least one set of members was selected for design. The maximum design ratios are listed according to sets of members. The number of the member with the highest design ratio within each set of members is shown in column A.

4.4 Design by Member

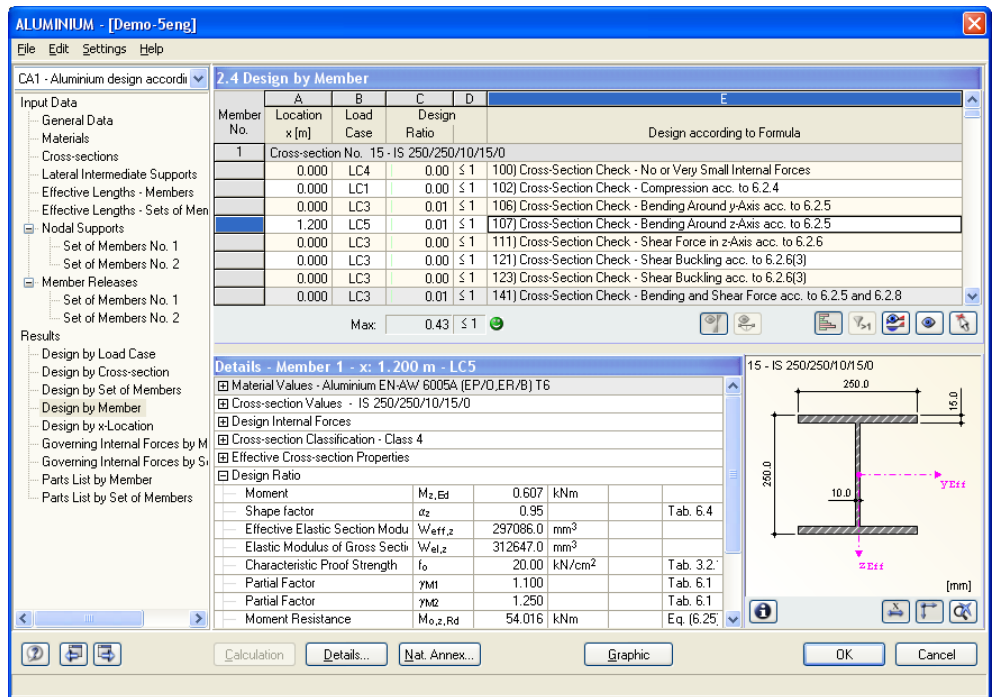
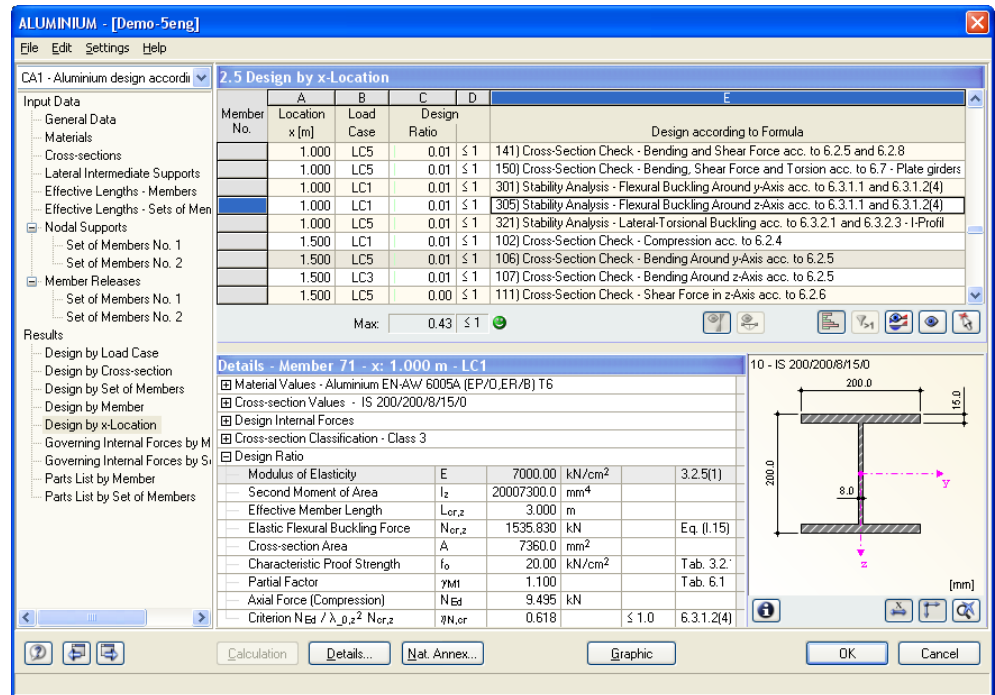

Figure 4.4: Table 2.4 Design by Member

In this table, the maximum design ratios arranged according to member numbers. The *Location x* at which the maximum value occurs is stated for every member.

The description of the individual columns can be found in chapter 4.1 on page 34.

4.5 Design by x-Location



Member No.	A Location x [m]	B Load Case	C Design Ratio	D	E
	1.000	LC5	0.01	≤ 1	141) Cross-Section Check - Bending and Shear Force acc. to 6.2.5 and 6.2.8
	1.000	LC5	0.01	≤ 1	150) Cross-Section Check - Bending, Shear Force and Torsion acc. to 6.7 - Plate girders
	1.000	LC1	0.01	≤ 1	301) Stability Analysis - Flexural Buckling Around y-Axis acc. to 6.3.1.1 and 6.3.1.2(4)
	1.000	LC1	0.01	≤ 1	305) Stability Analysis - Flexural Buckling Around z-Axis acc. to 6.3.1.1 and 6.3.1.2(4)
	1.000	LC5	0.01	≤ 1	321) Stability Analysis - Lateral-Torsional Buckling acc. to 6.3.2.1 and 6.3.2.3 - I-Profile
	1.500	LC1	0.01	≤ 1	102) Cross-Section Check - Compression acc. to 6.2.4
	1.500	LC5	0.01	≤ 1	106) Cross-Section Check - Bending Around y-Axis acc. to 6.2.5
	1.500	LC3	0.01	≤ 1	107) Cross-Section Check - Bending Around z-Axis acc. to 6.2.5
	1.500	LC5	0.00	≤ 1	111) Cross-Section Check - Shear Force in z-Axis acc. to 6.2.6

Max: 0.43 ≤ 1

Details - Member 71 - x: 1.000 m - LC1

- Material Values - Aluminium EN-AW 6005A (EP/D, ER/B) T6
- Cross-section Values - IS 200/200/8/15/0
- Design Internal Forces
- Cross-section Classification - Class 3
- Design Ratio

Modulus of Elasticity	E	7000.00	kN/cm ²	3.2.5(1)
Second Moment of Area	I _z	20007300.0	mm ⁴	
Effective Member Length	L _{cr,z}	3.000	m	
Elastic Flexural Buckling Force	N _{cr,z}	1535.830	kN	Eq. (I.15)
Cross-section Area	A	7360.0	mm ²	
Characteristic Proof Strength	f ₀	20.00	kN/cm ²	Tab. 3.2
Partial Factor	γ _{M1}	1.100		Tab. 6.1
Axial Force (Compression)	N _{Ed}	9.495	kN	
Criterion N _{Ed} / λ _{0,z} ² N _{cr,z}	γ _{N,cr}	0.618		≤ 1.0 6.3.1.2(4)

Figure 4.5: Table 2.5 Design by x-Location

This results table lists the maximum values of every member at the following locations *x* according to the division points of RSTAB:

- Start and end nodes
- Internal nodes according to a potential user-defined member division
- Divisions for member results according to settings in RSTAB dialog box *Calculation Parameters, Options* tab
- Extreme values of internal forces

4.6 Governing Internal Forces by Member

In this table, the governing internal forces are shown which lead to the maximum design ratios.

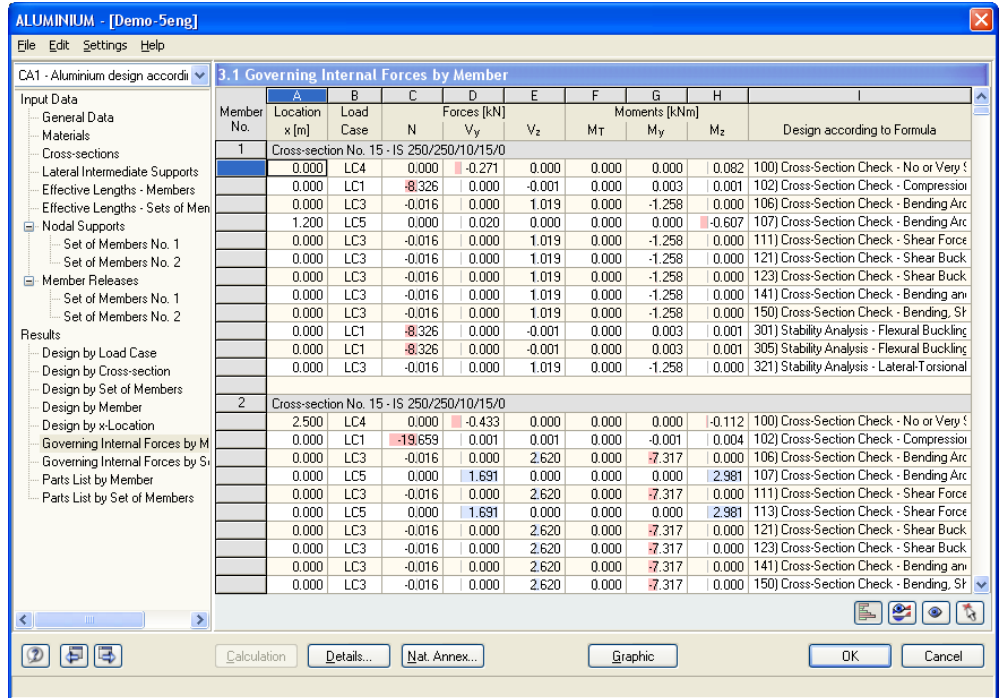

Member No.	Location x [m]	Load Case	Forces [kN]			Moments [kNm]			Design according to Formula
			N	V _y	V _z	M _T	M _y	M _z	
1 Cross-section No. 15 - IS 250/250/10/15/0									
0.000	LC4	0.000	-0.271	0.000	0.000	0.000	0.082	100	Cross-Section Check - No or Very S
0.000	LC1	-8.326	0.000	-0.001	0.000	0.003	0.001	102	Cross-Section Check - Compression
0.000	LC3	-0.016	0.000	1.019	0.000	-1.258	0.000	106	Cross-Section Check - Bending Arc
1.200	LC5	0.000	0.020	0.000	0.000	0.000	-0.607	107	Cross-Section Check - Bending Arc
0.000	LC3	-0.016	0.000	1.019	0.000	-1.258	0.000	111	Cross-Section Check - Shear Force
0.000	LC3	-0.016	0.000	1.019	0.000	-1.258	0.000	121	Cross-Section Check - Shear Buck
0.000	LC3	-0.016	0.000	1.019	0.000	-1.258	0.000	123	Cross-Section Check - Shear Buck
0.000	LC3	-0.016	0.000	1.019	0.000	-1.258	0.000	141	Cross-Section Check - Bending am
0.000	LC3	-0.016	0.000	1.019	0.000	-1.258	0.000	150	Cross-Section Check - Bending, SF
0.000	LC1	-8.326	0.000	-0.001	0.000	0.003	0.001	301	Stability Analysis - Flexural Buckling
0.000	LC1	-8.326	0.000	-0.001	0.000	0.003	0.001	305	Stability Analysis - Flexural Buckling
0.000	LC3	-0.016	0.000	1.019	0.000	-1.258	0.000	321	Stability Analysis - Lateral-Torsional
2 Cross-section No. 15 - IS 250/250/10/15/0									
2.500	LC4	0.000	-0.433	0.000	0.000	0.000	-0.112	100	Cross-Section Check - No or Very S
0.000	LC1	-19.659	0.001	0.001	0.000	-0.001	0.004	102	Cross-Section Check - Compression
0.000	LC3	-0.016	0.000	2.620	0.000	-7.317	0.000	106	Cross-Section Check - Bending Arc
0.000	LC5	0.000	1.691	0.000	0.000	0.000	2.981	107	Cross-Section Check - Bending Arc
0.000	LC3	-0.016	0.000	2.620	0.000	-7.317	0.000	111	Cross-Section Check - Shear Force
0.000	LC5	0.000	1.691	0.000	0.000	0.000	2.981	113	Cross-Section Check - Shear Force
0.000	LC3	-0.016	0.000	2.620	0.000	-7.317	0.000	121	Cross-Section Check - Shear Buck
0.000	LC3	-0.016	0.000	2.620	0.000	-7.317	0.000	123	Cross-Section Check - Shear Buck
0.000	LC3	-0.016	0.000	2.620	0.000	-7.317	0.000	141	Cross-Section Check - Bending am
0.000	LC3	-0.016	0.000	2.620	0.000	-7.317	0.000	150	Cross-Section Check - Bending, SF

Figure 4.6: Table 3.1 Governing Internal Forces by Member

Location x

For every member, the location x on the member with the maximum design ratio is shown.

Load Case

In this column, the numbers of the load cases, load groups or combinations whose internal forces have the most unfavorable effects.

Forces / Moments

The decisive axial and shear forces as well as the torsional and bending moments are listed for every member.

Design according to Formula

The last column includes the relevant equations that were followed in the design.

4.7 Governing Internal Forces by Set of Members

ALUMINIUM - [Demo-5eng]

CA1 - Aluminium design according to...

3.2 Governing Internal Forces by Set of Members

Set No.	A	B	C	D	E	F	G	H	
	Location x [m]	Load Case	N	Forces [kN] V _y	V _z	M _T	M _y	M _z	Design according to Formula
1	(Member No. 14,18,27,46,65,79,88,102)								
	2.689	LC5	0.000	-0.011	0.000	0.008	0.000	-0.134	100) Cross-Section Check - No or Very
	0.000	LC1	-20.995	0.000	-3.771	0.000	0.000	0.000	102) Cross-Section Check - Compression
	5.647	LC1	-3.788	0.002	0.029	0.000	13.229	0.001	106) Cross-Section Check - Bending Arc
	3.000	LC4	0.000	0.001	0.000	0.005	0.000	1.796	107) Cross-Section Check - Bending Arc
	0.000	LC1	-4.906	-0.002	5.983	0.000	-22.628	0.000	111) Cross-Section Check - Shear Buck
	0.000	LC1	-4.906	-0.002	5.983	0.000	-22.628	0.000	121) Cross-Section Check - Shear Buck
	0.000	LC1	-20.995	0.000	-3.771	0.000	0.000	0.000	122) Cross-Section Check - Shear Buck
	0.000	LC1	-20.995	0.000	-3.771	0.000	0.000	0.000	123) Cross-Section Check - Shear Buck
	1.000	LC3	0.648	0.000	2.359	0.000	2.609	0.000	129) Cross-Section Check - Flange Indu
	3.585	LC1	-3.877	0.002	1.041	0.000	12.126	0.005	141) Cross-Section Check - Bending an
	3.585	LC1	-3.877	0.002	1.041	0.000	12.126	0.005	150) Cross-Section Check - Bending, SF
	0.000	LC1	-4.906	-0.002	5.983	0.000	-22.628	0.000	171) Cross-Section Check - Bending, SF
	0.000	LC1	-4.906	-0.002	5.983	0.000	-22.628	0.000	180) Cross-Section Check - Bending, SF
	0.000	LC1	-20.995	0.000	-3.771	0.000	0.000	0.000	301) Stability Analysis - Flexural Buckling
	1.631	LC1	-4.110	-0.002	3.702	0.000	-0.145	0.009	305) Stability Analysis - Flexural Buckling
	0.000	LC1	-20.995	0.000	-3.771	0.000	0.000	0.000	306) Stability Analysis - Flexural Buckling
	5.647	LC1	-3.788	0.002	0.029	0.000	13.229	0.001	321) Stability Analysis - Lateral-Torsional
	1.000	LC1	-18.569	0.000	-3.771	0.000	-3.771	0.000	331) Stability Analysis - Bending Around
	0.000	LC1	-20.995	0.000	-3.771	0.000	0.000	0.000	352) Stability Analysis - Flexural Buckling
	1.631	LC1	-4.110	-0.002	3.702	0.000	-0.145	0.009	355) Stability Analysis - Flexural Buckling
	0.000	LC1	-20.995	0.000	-3.771	0.000	0.000	0.000	356) Stability Analysis - Flexural Buckling
	5.647	LC1	-3.788	0.002	0.029	0.000	13.229	0.001	371) Stability Analysis - Lateral-Torsional
	1.000	LC1	-18.569	0.000	-3.771	0.000	-3.771	0.000	381) Stability Analysis - Bending Around

Figure 4.7: Table 3.2 Governing Internal Forces by Set of Member

This results table presents the governing internal forces that lead to the maximum design ratios of every set of members.

4.8 Member Slendernesses

ALUMINIUM - [Demo-5eng]

CA1 - Aluminium design according to...

3.3 Member Slendernesses

Member No.	A	B	C	D	E	F	G	H
	Under Stress	Length L [m]	k _y	Major Axis y i _y [mm]	λ _y	k _z	Minor Axis z i _z [mm]	λ _z
1	Compression/Flexure	3.000	1.000	107.7	27.849	1.000	63.5	47.263
2	Compression/Flexure	3.000	1.000	107.7	27.849	1.000	63.5	47.263
3	Compression/Flexure	5.000	1.000	30.7	162.938	1.000	30.7	162.938
4	Compression/Flexure	5.000	1.000	30.7	162.938	1.000	30.7	162.938
5	Compression/Flexure	3.000	1.000	188.0	15.960	1.000	47.0	63.863
6	Compression/Flexure	3.000	1.000	188.0	15.960	1.000	47.0	63.863
7	Compression/Flexure	5.000	1.000	30.7	162.938	1.000	30.7	162.938
8	Compression/Flexure	6.000	1.000	188.0	31.921	1.000	47.0	127.727
9	Compression/Flexure	5.000	1.000	30.7	162.938	1.000	30.7	162.938
12	Compression/Flexure	6.000	1.000	188.0	31.921	1.000	47.0	127.727
13	Compression/Flexure	5.000	1.000	30.7	162.938	1.000	30.7	162.938
14	Compression/Flexure	6.000	1.000	188.0	31.921	1.000	47.0	127.727
15	Compression/Flexure	3.011	1.000	167.2	18.010	1.000	47.1	63.958
16	Compression/Flexure	3.011	1.000	167.2	18.010	1.000	47.1	63.958
17	Compression/Flexure	3.011	1.000	167.2	18.010	1.000	47.1	63.958
18	Compression/Flexure	3.011	1.000	167.2	18.010	1.000	47.1	63.958
19	Compression/Flexure	6.274	1.000	107.7	58.240	1.000	63.5	98.841
20	Compression/Flexure	6.250	1.000	188.0	33.251	1.000	47.0	133.049
21	Compression/Flexure	6.250	1.000	188.0	33.251	1.000	47.0	133.049
24	Compression/Flexure	3.262	1.000	167.2	19.512	1.000	47.1	69.292
25	Compression/Flexure	3.262	1.000	167.2	19.512	1.000	47.1	69.292
26	Compression/Flexure	3.262	1.000	167.2	19.512	1.000	47.1	69.292

Members with Compression / Flexure:
 Max λ_y: 162.938 ≤ 200
 Max λ_z: 199.581 ≤ 200

Figure 4.8: Table 3.3 Member Slendernesses

Details...

In table 3.3, the effective slenderness ratios of all designed members are compared to the maximum values that were set in the *Details* dialog box (see chapter 3.1.4, page 31). These ratios are listed with respect to the major and minor principal axes. The table provides information on the maximum effective slenderness ratios only, it does not give any design results.

Members of the types "Tension" or "Cable" are excluded from this table.

4.9 Parts List by Member

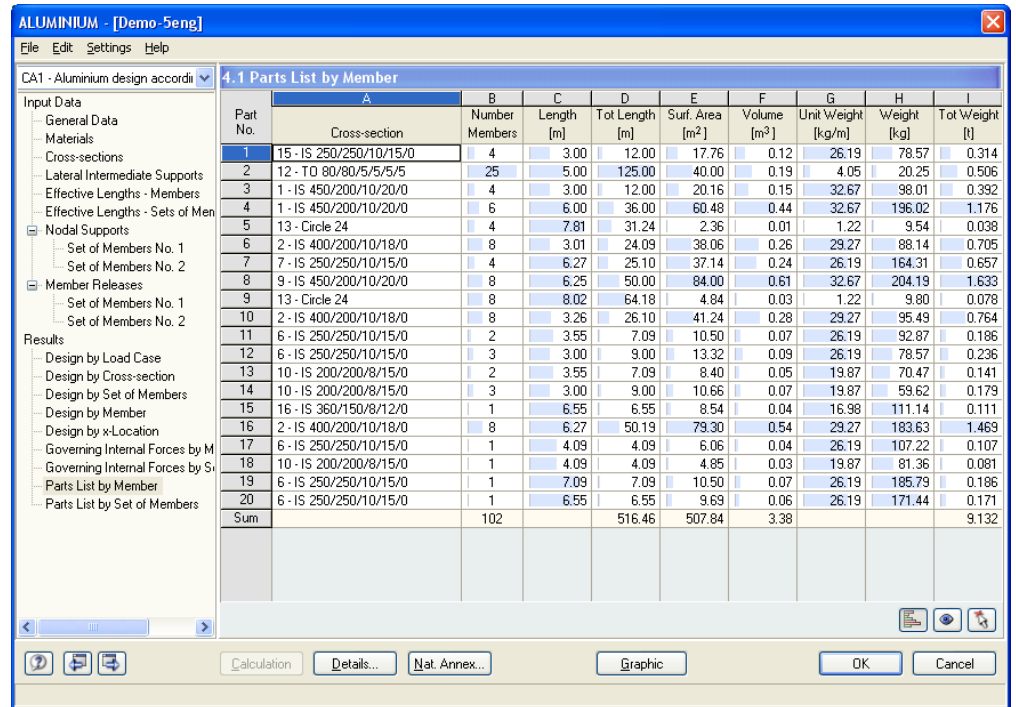

Part No.	A Cross-section	B Number	C Length [m]	D Tot Length [m]	E Surf. Area [m ²]	F Volume [m ³]	G Unit Weight [kg/m]	H Weight [kg]	I Tot Weight [t]
1	15 - IS 250/250/10/15/0	4	3.00	12.00	17.76	0.12	26.19	78.57	0.314
2	12 - T0 80/80/5/5/5/5	25	5.00	125.00	40.00	0.19	4.05	20.25	0.506
3	1 - IS 450/200/10/20/0	4	3.00	12.00	20.16	0.15	32.67	98.01	0.392
4	1 - IS 450/200/10/20/0	6	6.00	36.00	60.48	0.44	32.67	196.02	1.176
5	13 - Circle 24	4	7.81	31.24	2.36	0.01	1.22	9.54	0.038
6	2 - IS 400/200/10/18/0	8	3.01	24.09	38.06	0.26	29.27	88.14	0.705
7	7 - IS 250/250/10/15/0	4	6.27	25.10	37.14	0.24	26.19	164.31	0.657
8	9 - IS 450/200/10/20/0	8	6.25	50.00	84.00	0.61	32.67	204.19	1.633
9	13 - Circle 24	8	8.02	64.18	4.84	0.03	1.22	9.80	0.078
10	2 - IS 400/200/10/18/0	8	3.26	26.10	41.24	0.28	29.27	95.49	0.764
11	6 - IS 250/250/10/15/0	2	3.55	7.09	10.50	0.07	26.19	92.87	0.186
12	6 - IS 250/250/10/15/0	3	3.00	9.00	13.32	0.09	26.19	78.57	0.236
13	10 - IS 200/200/8/15/0	2	3.55	7.09	8.40	0.05	19.87	70.47	0.141
14	10 - IS 200/200/8/15/0	3	3.00	9.00	10.66	0.07	19.87	59.62	0.179
15	16 - IS 360/150/8/12/0	1	6.55	6.55	8.54	0.04	16.98	111.14	0.111
16	2 - IS 400/200/10/18/0	8	6.27	50.19	79.30	0.54	29.27	183.63	1.469
17	6 - IS 250/250/10/15/0	1	4.09	4.09	6.06	0.04	26.19	107.22	0.107
18	10 - IS 200/200/8/15/0	1	4.09	4.09	4.85	0.03	19.87	81.36	0.081
19	6 - IS 250/250/10/15/0	1	7.09	7.09	10.50	0.07	26.19	185.79	0.186
20	6 - IS 250/250/10/15/0	1	6.55	6.55	9.69	0.06	26.19	171.44	0.171
Sum		102		516.46	507.84	3.38			9.132

Figure 4.9: Table 4.1 *Parts List by Member*

Details...

This table represents a parts list of all cross-sections that are considered in the design case. By default, only designed members are included. If all members of the structure are to be covered, you have to change the relevant setting in the *Details* dialog box (cf. Figure 3.4, page 31) that can be opened via the [Details] button.

Part No.

The same part number is automatically assigned to identical members.

Cross-section

In this column, the cross-section description is displayed.

Number of Members

The number of identical members is given for each part.

Length

This column displays the unit lengths of every single member.

Total Length

The values of this column represent the product of the two previous columns.



Surface Area

The surface area which is related to the total length of the relevant part is calculated on the basis of the value A_{surf} of each cross-section. You can check on this value by clicking on the [Info] button in tables 1.3 or 2.1 to 2.5 (cf. Figure 2.9, page 15).

Volume

The volume of every part is calculated from the surface area and the total length.

Unit Weight

The *Unit Weight* of the cross-section represents the weight per length of 1 m.

Weight

The value in this column is calculated as the product of values in the columns C and G.

Total Weight

The total weight of each part is displayed in the last column.

Sum

The sums of the values in the individual columns are given in the final row of the list. The cell *Total Weight* shows the total required amount of steel.

4.10 Parts List by Set of Members

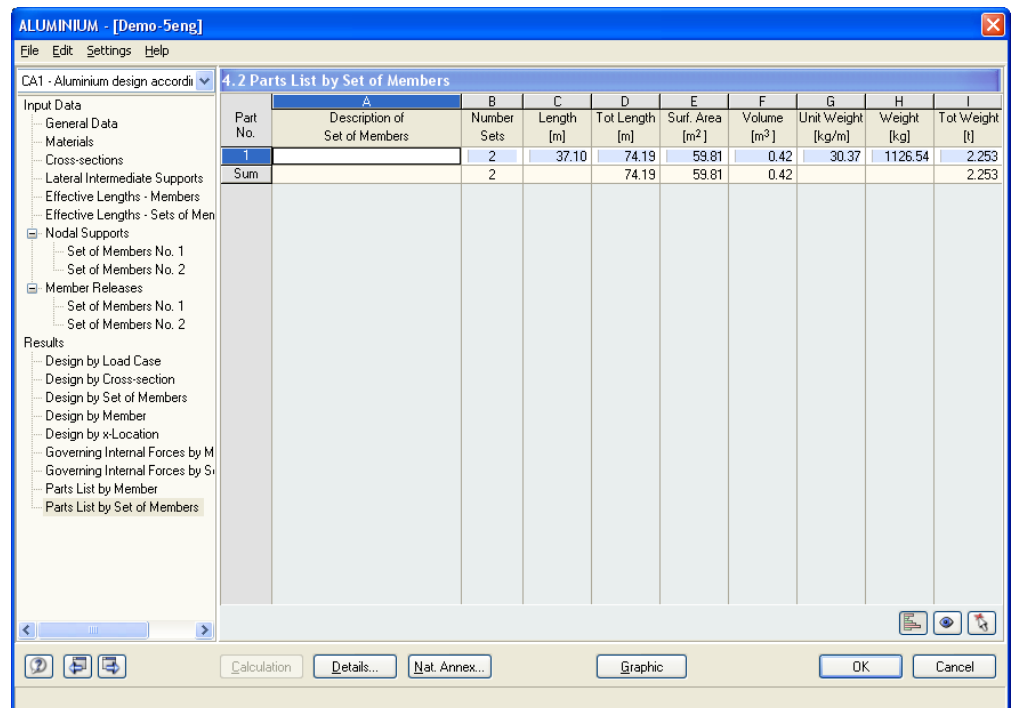

Part No.	Description of Set of Members	Number Sets	Length [m]	Tot Length [m]	Surf. Area [m ²]	Volume [m ³]	Unit Weight [kg/m]	Weight [kg]	Tot Weight [t]
1		2	37.10	74.19	59.81	0.42	30.37	1126.54	2.253
Sum		2		74.19	59.81	0.42			2.253

Figure 4.10: Table 4.2 *Parts List by Set of Members*

The last table in ALUMINIUM is presented when at least one set of members was selected for the design. The advantage of this table is that a parts list is given for the various groups of elements (e.g. for a beam).

The table columns are described in the previous chapter. If there are different cross-sections within the set of members, the mean values of surface area, volume and unit weight are listed here.

5. Evaluation of Results

The design results can be evaluated in different ways. For this, the buttons in the results tables are very useful. They are located below the upper tables.

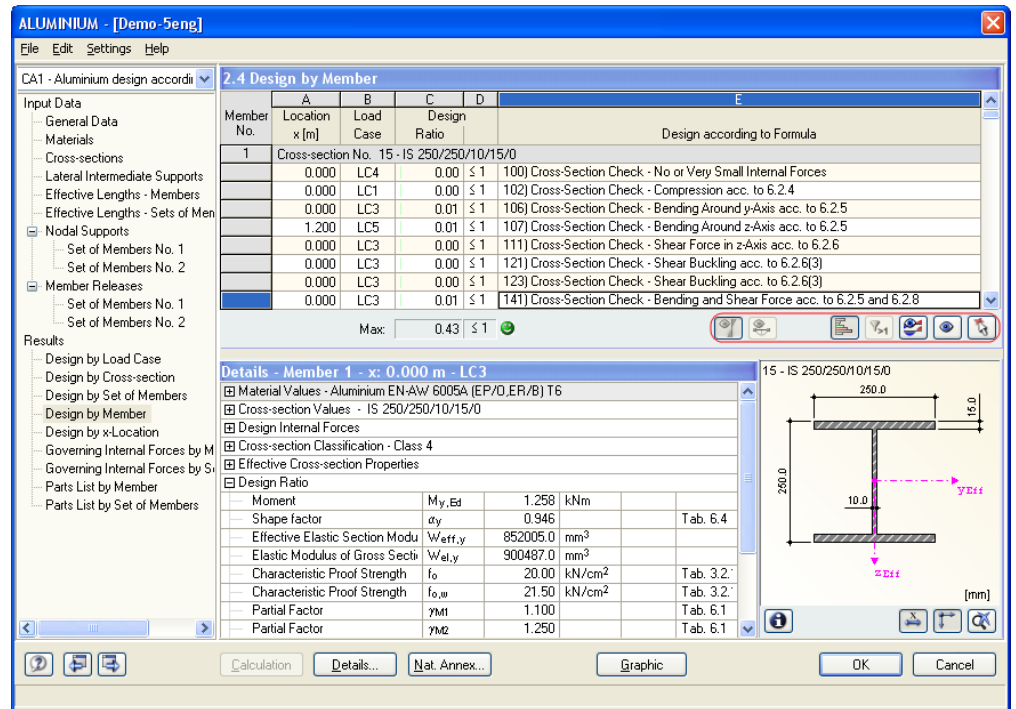

Figure 5.1: Buttons for evaluation of results

These buttons have the following functions:







Button	Name	Function
	Design of ultimate limit state	Switch on/off the design results of the ultimate limit state
	Design of serviceability limit state	Switch on/off the design results of the serviceability limit state
	Show color bars in table	Switch on/off the color background in the results tables according to the reference scale
	Show rows with ratio > 1	Show only rows with stress ratios greater than 1 and, accordingly, the failed design
	Show result diagrams of current member	Open the diagram <i>Result Diagram on Member</i> → Chapter 5.2, page 45
	Jump to graphics to change view	Go to the RSTAB work window in order to change the display settings
	Pick member in graphics and go to member in table	Click on a specific member in the RSTAB window whose result values are to be displayed in the ALUMINIUM table

Table. 5.1: Buttons in results tables 2.1 to 2.5

5.1 Results on RSTAB Model

You can use the RSTAB work window to evaluate the design results.

RSTAB Background Graphics and View Mode

The RSTAB graphics in the background can be useful if you want to check the location of a specific member in the model: the member that is selected in the ALUMINIUM results table is also highlighted in the selection color in the RSTAB background graphics. Additionally, an arrow marks the member location x which is stated as decisive in the selected line.

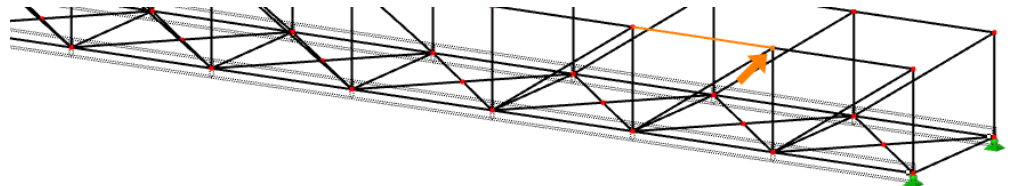

The screenshot shows the ALUMINIUM software interface. The main window displays a table of design results for member 72 at location x = 0.000 m. The table includes columns for Member No., Location x [m], Load Case, Design Ratio, and Design according to Formula.

Member No.	Location x [m]	Load Case	Design Ratio	Design according to Formula
0.000	0.000	LG2	0.00 ≤ 1	123) Cross-Section Check - Shear Buckling acc. to 6.2.6(3)
0.857	0.857	LG2	0.01 ≤ 1	131) Cross-Section Check - Torsion acc. to 6.2.7.2
0.000	0.000	LG2	0.00 ≤ 1	132) Cross-Section Check - Torsion and Shear Force in z-Axis acc. to 6.2.7.3
3.000	3.000	LG2	0.00 ≤ 1	134) Cross-Section Check - Torsion and Shear Force in y-Axis acc. to 6.2.7.3
1.500	1.500	LG2	0.12 ≤ 1	196) Cross-Section Check - Biaxial Bending, Shear, Torsion and Axial Force acc. to 6.2.7.3
0.000	0.000	LG2	0.28 ≤ 1	334) Stability Analysis - Bending and Compression acc. to 6.3.3

Below the table, the 'Details - Member 72 - x: 0.000 m - LG2' section is visible, showing material values (Aluminium EN-AW 6005A), cross-section values (IS 160/160/6/10/0), and design ratios for various failure modes like Ideal Torsional Buckling Load and Relative Slenderness.

Figure 5.2: Selection of member and current Location x in RSTAB model

If you do not get a favorable view even by moving the ALUMINIUM window, you can apply the so-called *View Mode* by clicking on the [Change View] button: the ALUMINIUM window is switched off and you can change the view on the RSTAB model. In this mode, the functions from the *View* menu are available, e.g. zoom, move or rotate the view.

Use the [Back] button to return to the ALUMINIUM module.

RSTAB Work Window

The design ratios can be also displayed directly on the structural model. Close ALUMINIUM via the [Graphic] button. The design ratios are then shown graphically in the RSTAB work window.

Similarly to the internal forces in RSTAB, you can activate or deactivate the design results by the [Results on/off] button. The [Show Result Values] button controls the display of the numerical values in the graphics.

The image shows an information dialog box with the text "You are in the view mode." and a "Back" button. Below it are two buttons: "Graphic" and "X...X".

Regarding the fact that the RSTAB tables are irrelevant to evaluate any ALUMINIUM results, you can deactivate them via the button visible on the left.

A particular design case can be selected from the list of cases in the RSTAB toolbar.

The display of results can also be controlled by the *Display* navigator, using the entry *Results* → *Members*. The design ratio is displayed *Two Colored* by default.

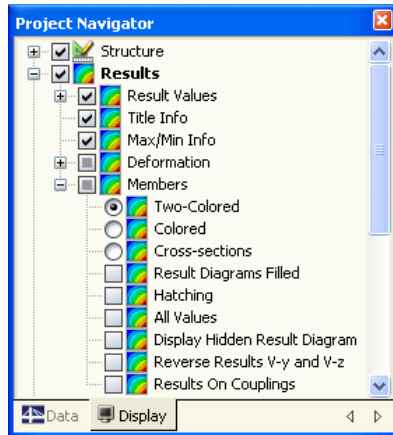
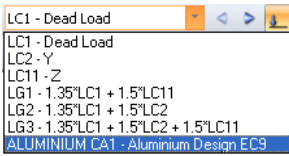

Figure 5.3: *Display Navigator: Results* → *Members* → *Two Colored*

If you select the *Colored* results display, the color tab of the Panel becomes available that offers various options for the multicolor display. Those are described in chapter 4.4.6 of the RSTAB manual.

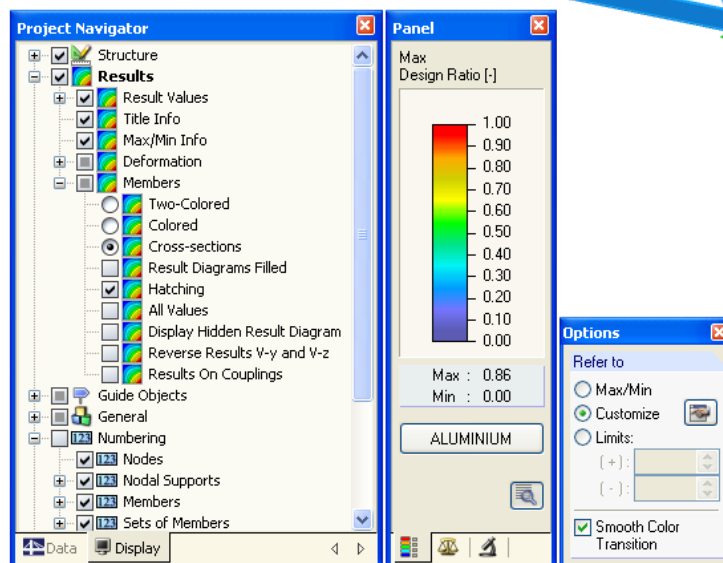
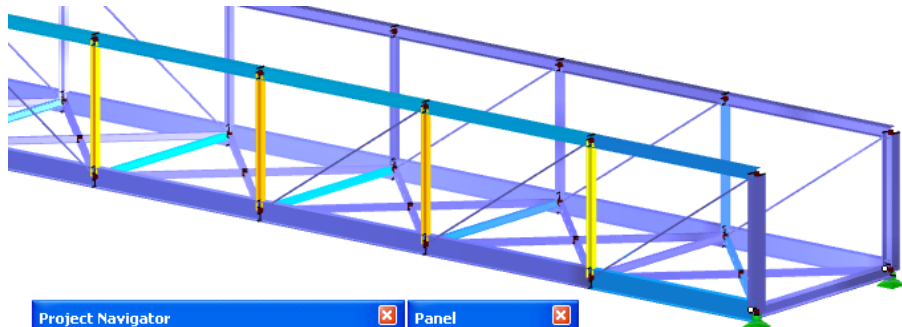

Figure 5.4: Design ratios for option *Cross-sections* in the *Display Navigator*



Similarly to member internal forces, you can set a scale factor for the graphics of the design ratios in the *Factors* tab. If you enter the factor 0 in the *Member Diagrams* input field, the design ratios will be shown with an increased line thickness.

This graphic view can be incorporated to the global printout report (see chapter 6.2, page 48).



You can return to the add-on module any time by clicking on the [ALUMINIUM] button in the panel.

5.2 Result Diagrams



In order to view the detailed distribution of results of a specific member, the graph of results can be used. Select the relevant member (or set of members) in the results table of ALUMINIUM by placing the cursor in the table line of the member. Then activate the diagram by clicking the button as seen to the left. It is located below the upper tables of results (cf. Figure 5.1, page 42).

In the RSTAB window, the result diagrams are available via the main menu

Results → Member Results

or by using the corresponding button in the toolbar.

A new window is opened in which the result diagrams on the selected member or set of members are shown.

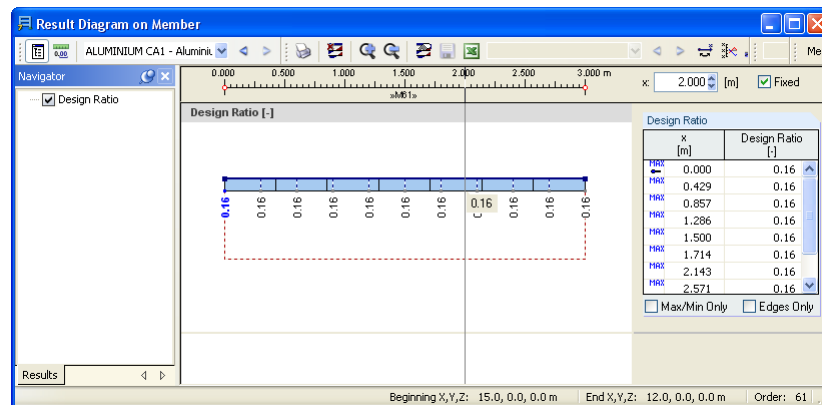
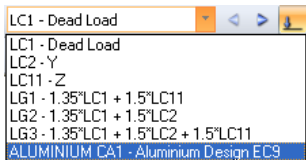

Figure 5.5: Result Diagram on Member Dialog



A particular design case can be selected in the list in the toolbar.

The *Result Diagram on Member* dialog box is described in detail in chapter 9.8.4 of the RSTAB manual on page 206.

5.3 Filtering Results

The structure of the ALUMINIUM tables makes it already possible to select the results according to certain criteria. Additionally, you can use the filter functions as described in the RSTAB manual to graphically evaluate ALUMINIUM results.

Partial Views



You can use already defined partial views that group specific objects in a suitable way. This function is described in the RSTAB manual, chapter 9.8.6).

Filtering Design Ratios

Secondly, you can set the design ratios as criteria for filtering the results in the RSTAB work window. For this, the so-called control panel is to be displayed. If it is not visible, you can switch it on in the main menu



View → Control panel

or by clicking on the corresponding button in the *Results* toolbar.

This panel is described in chapter 4.4.6 of the RSTAB manual. The filter settings of the results are defined in the *Color Spectrum* tab of the panel. If this tab is not available (in case of a two-colored display), it has to be switched on by selecting one of the display options *Colored* or *Cross-sections* in the *Display* navigator.

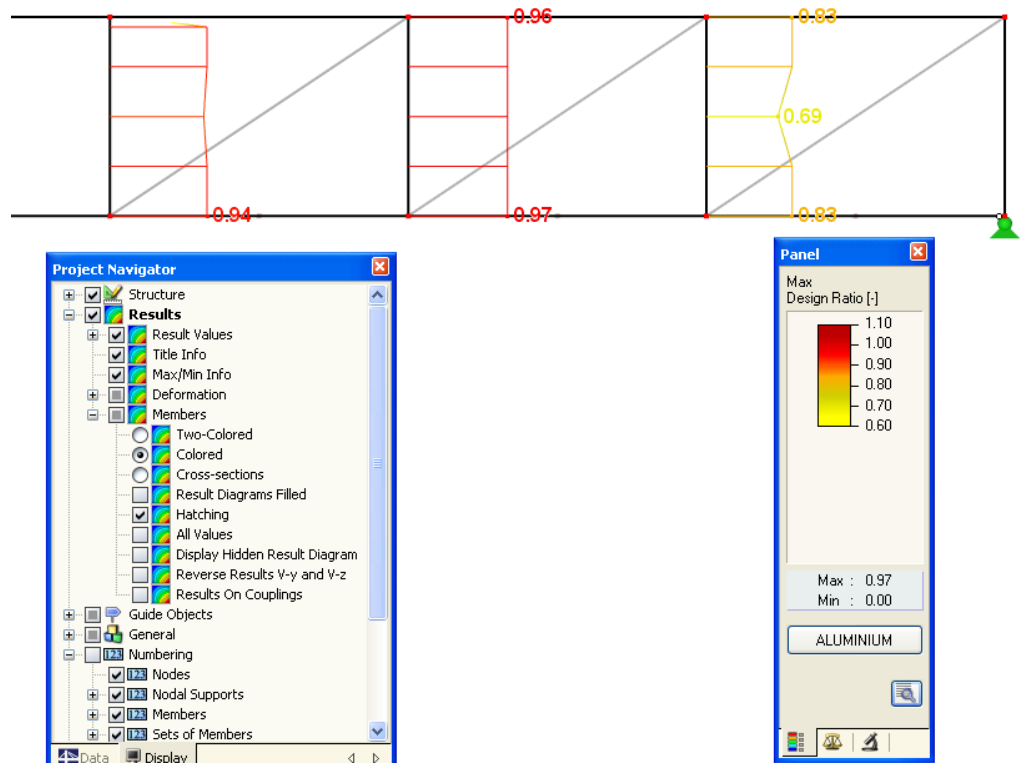

Figure 5.6: Filtering design ratios with adjusted color spectrum

For a colored view of the results, you can set in the panel that e.g. only design ratios greater than 0.60 are to be displayed. Furthermore, the color spectrum can be adjusted in a way that one color range exactly covers the design ratio 0.10 (see figure above).

By the option *Display hidden result diagram* (*Display* navigator, entry *Results* → *Members*) you can also display design results that do not satisfy the given condition. Those design diagrams will then be drawn as dashed lines.

Filtering Members



In the *Filter* tab of the Panel, you can enter the numbers of the members whose result design ratios are to be shown in the graphics. This function is described in chapter 9.8.6 of the RSTAB manual on page 215.

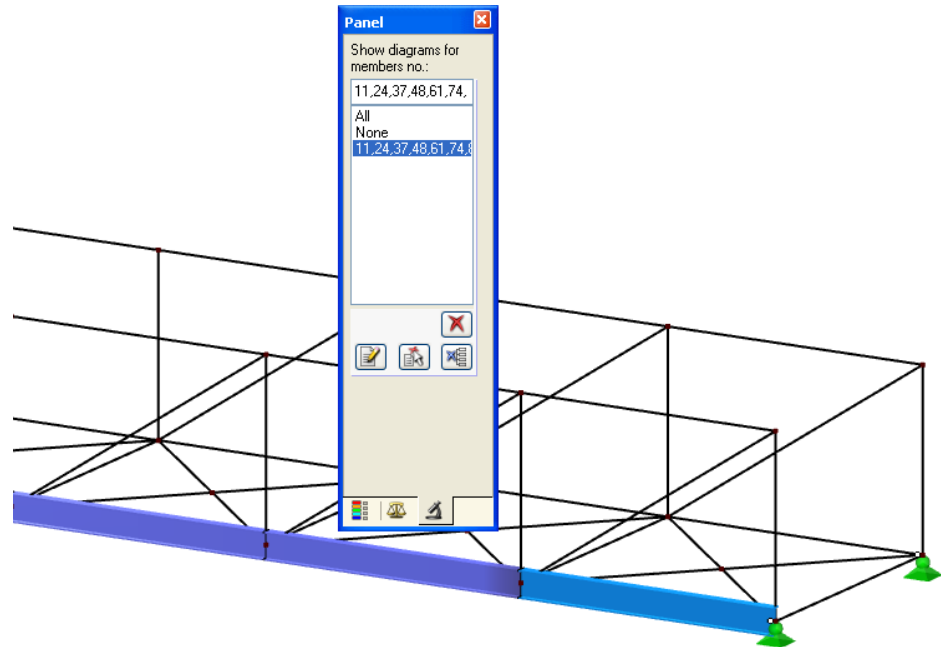

Figure 5.7: Filtering members to display design ratios of bottom chord

Contrary to the partial view function, the entire structure is displayed. The figure above shows the design ratios in the bottom chord of a footbridge. All other designed members of the structure are displayed in the model, but they are without any design ratios.

6. Printout

6.1 Printout Report

For all data of ALUMINIUM, a printout report can be created to which you can add graphics and comments. In this printout report, it is also possible to select the input and results tables of ALUMINIUM that are to be printed.

The printout report is described in detail in the manual of RSTAB. In particular, chapter 10.1.3.4 *Selecting Data of Add-on Modules* on page 227 is important. It deals with the selection of input and output data in all add-on modules.

For very large models, it is recommended to use several smaller reports instead of a single extensive one. If you create a specific report only for the ALUMINIUM data, the printout report will be processed fairly quickly.

6.2 Print ALUMINIUM Graphics

It is possible to print the design ratios that are displayed on the RSTAB model. All graphics can be incorporated to the printout report or sent directly to the printer. Chapter 10.2 of the RSTAB manual describes in detail how to print graphic displays.

Results on RSTAB Model



Every image of the RSTAB work window can be included in the printout report. The current ALUMINIUM graphics is printed by using the main menu

File → Print...

or by clicking on the corresponding button in the toolbar.

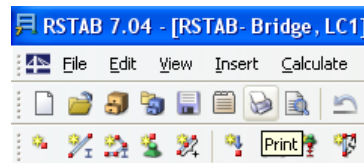

Figure 6.1: *Print* button in toolbar of main window

Result Diagram



You can also print the result diagrams of members by clicking on the [Print] button in the *Result Diagram on Member* window.

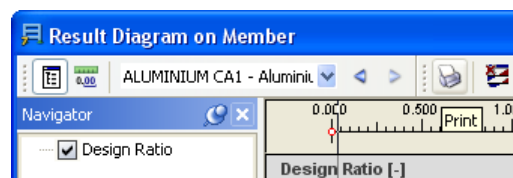

Figure 6.2: *Print* button in toolbar of *Result Diagram* window

The following dialog box opens.

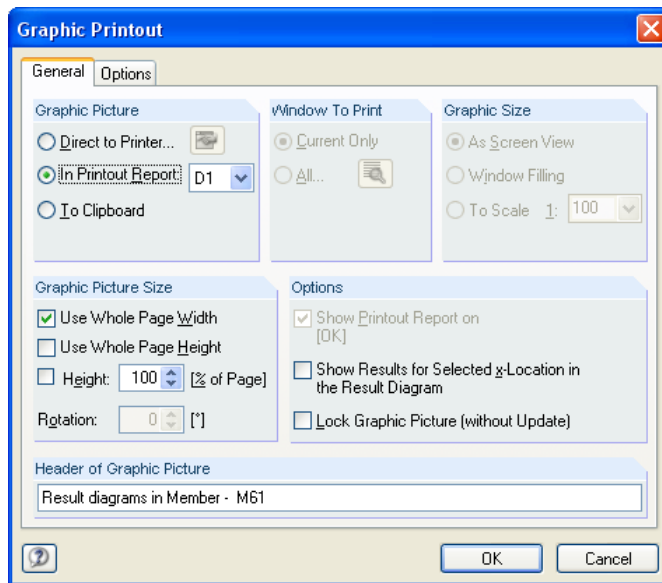

Figure 6.3: *Graphic Printout* dialog box, *General* tab

This dialog box is described in detail in chapter 10.2 of the RSTAB manual. The remaining two tabs *Options* and *Color Spectrum* are also explained there.

In the printout report, any image of the ALUMINIUM results can be moved to a different location via drag-and-drop. It is also possible to adjust inserted images subsequently: right mouse click on the relevant entry in the report navigator, then select *Properties* in its context menu. The *Graphic Printout* dialog box is displayed again in which the possible changes can be set.

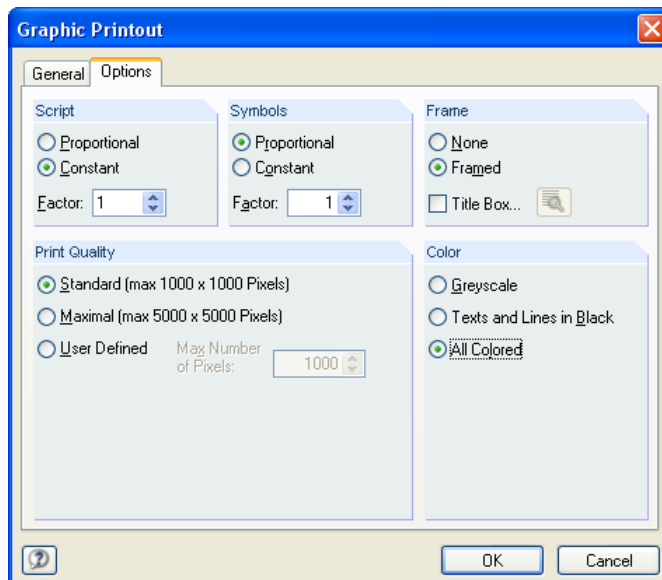
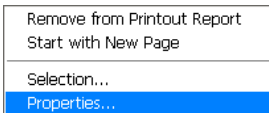

Figure 6.4: *Graphic Printout* dialog box, *Options* tab

7. General Functions

This chapter describes the commonly used functions of the main menu as well as the export options of the design results.

7.1 ALUMINIUM Design Cases

Members can be assigned to different design cases. In this way, it is possible to separately design some structural parts with specific parameters (e.g. modified material, partial safety factor or optimization).

A member or set of members can be analyzed in different design cases without any problem.

All design cases created in ALUMINIUM are contained in the list of load cases and load groups in the toolbar of the RSTAB work window.

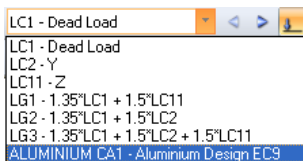

Create New ALUMINIUM Case

A new design case can be created from the ALUMINIUM main menu

File → New Case...

The following dialog box opens.

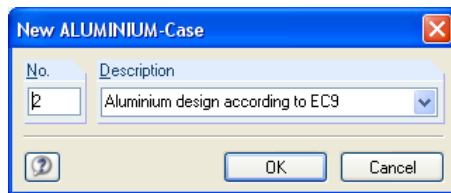

Figure 7.1: New ALUMINIUM Case dialog box

In this dialog box, you need to fill in the (not yet used) *Number* and *Description* of the new design case. After closing the dialog box with [OK], the ALUMINIUM table 1.1 *General Data* is shown where you can define the new design data.

Rename ALUMINIUM Case

The description of a design case can be changed via the ALUMINIUM main menu

File → Rename Case...

The *Rename ALUMINIUM Case* dialog box is opened.

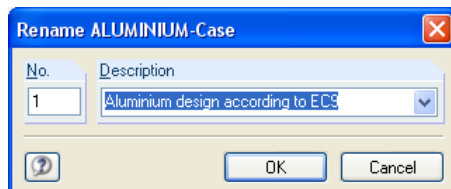

Figure 7.2: Rename ALUMINIUM Case dialog box

Copy ALUMINIUM Case

The input data of the current design case can be copied via the ALUMINIUM main menu

File → **Copy Case...**

The *Copy ALUMINIUM Case* dialog box opens. Enter the number and description of the new design case into which the selected case is to be copied.

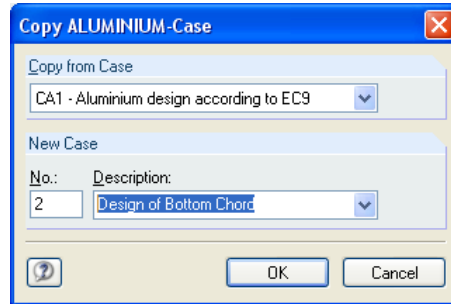

Figure 7.3: *Copy ALUMINIUM Case* dialog box

Delete ALUMINIUM Case

Design cases can be deleted via the ALUMINIUM main menu

File → **Delete Cases...**

In the *Delete Cases* dialog box, the design case can be selected from the list of *Available Cases*. It will be deleted when clicking on [OK].

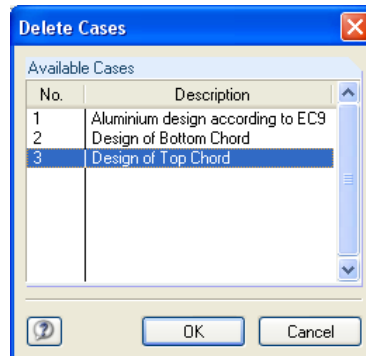
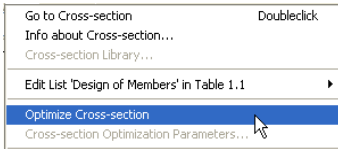

Figure 7.4: *Delete Cases* dialog box

7.2 Cross-Section Optimization

The module ALUMINIUM offers the possibility to optimize cross-sections. For this, select the cross-section that is to be optimized in column D resp. E of table 1.3 *Cross-sections* by ticking the appropriate box (cf. Figure 2.7 on page 14).

You can also start the optimization of a cross-section via the context menu in the results tables.



During the optimization, ALUMINIUM examines which cross-section within the same cross-sections series satisfies the design “optimally”, i.e. is the closest to the maximum allowable design ratio which has been defined in the *Details* dialog box, *Other* tab (see Figure 3.4, page 31). The required cross-section properties are calculated on the basis on the internal forces of RSTAB. Finally, the cross-section is chosen which satisfies the design with the highest possible design ratio. For this reason, two cross-sections are shown graphically in table 1.3 on the right – the original cross-section from RSTAB and the optimized one (see Figure 7.6).

When ticking the optimization box for parameterized cross-sections from the library, the following dialog box appears for you to enter detailed data.

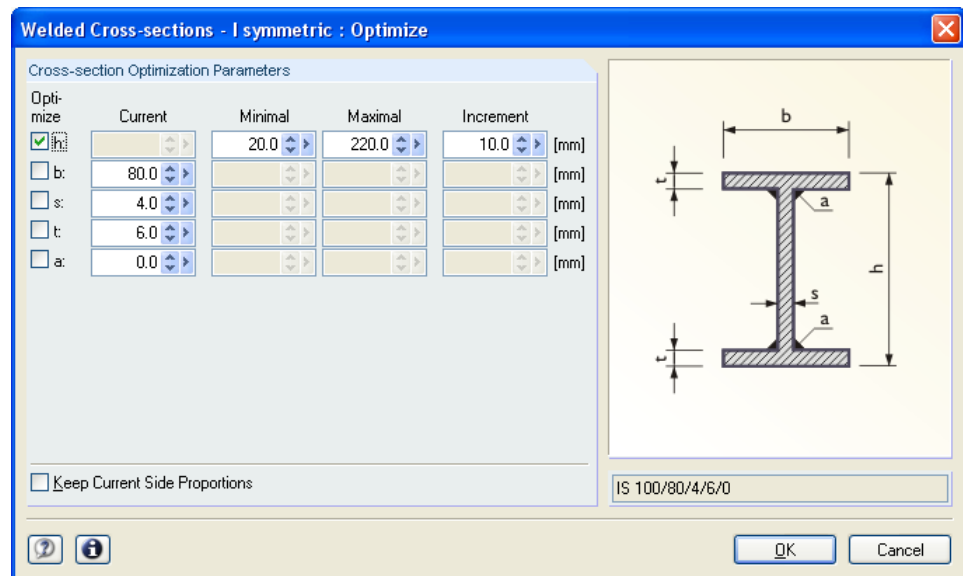

Figure 7.5: *Welded Cross-sections - I-Symmetric: Optimize* dialog box

At first, select the parameter(s) that you want to modify in column *Optimize*. Hence, the columns *Minimal* and *Maximal* become accessible where the upper and lower limits of each optimization parameter can be defined. The column *Increment* controls in which intervals the parameter dimensions vary during the optimization process.

If you want to *Keep Current Side Proportions*, tick the corresponding box in the lower part of this dialog box. Additionally, it is necessary to tick at least two parameters for the optimization to take effect.

It is not possible to carry out the optimization for combined rolled cross-sections.

Please keep in mind that during the optimization the internal forces will not be recalculated automatically on the basis of the modified cross-sections. It depends on the user’s decision when and which cross-sections are to be adapted in RSTAB for a new analysis. The internal forces based on the optimized cross-sections may differ considerably due to the changed rigidities within the structural model. Thus, we recommend recalculating the internal forces after one optimization run and then optimizing the cross-sections once more.



It is not necessary to transfer the modified cross-sections to RSTAB manually. Open table 1.3 *Cross-sections* and select in the main menu

Edit → Export All Cross-Sections to RSTAB

The option to export the modified cross-sections to RSTAB is also contained in the context menu of table 1.3

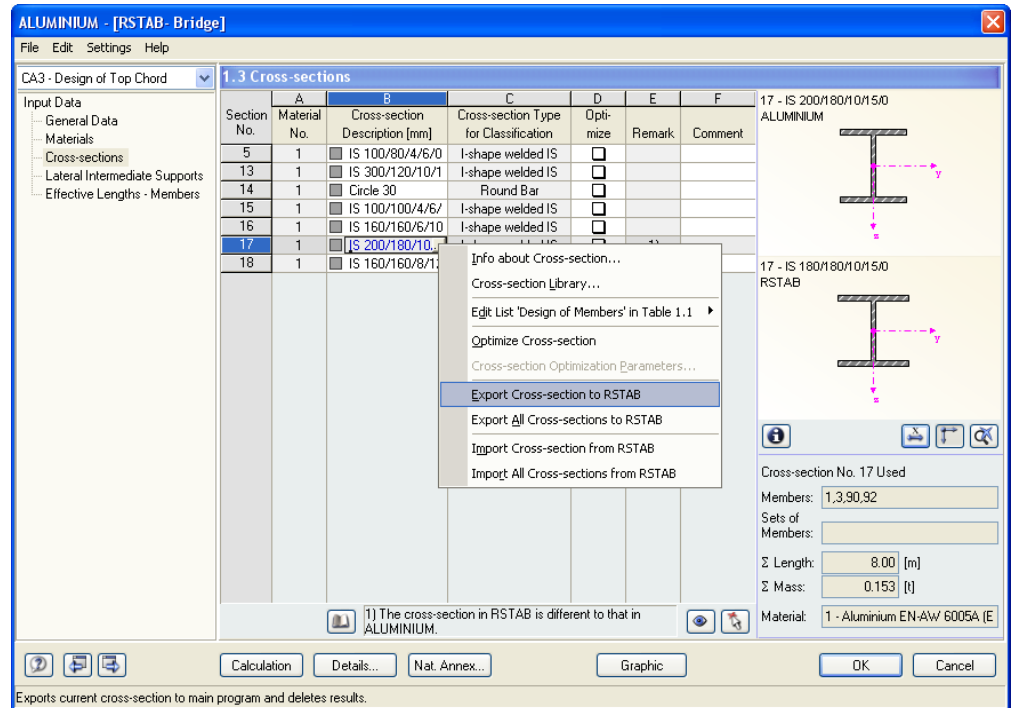

Figure 7.6: Context menu in table 1.3 *Cross-sections*

Before the cross-sections are transferred to RSTAB, a question appears because exporting also implies deleting the results. If you then start the [Calculation] in ALUMINIUM, the internal forces of RSTAB and the design ratios of ALUMINIUM are determined in one calculation run.

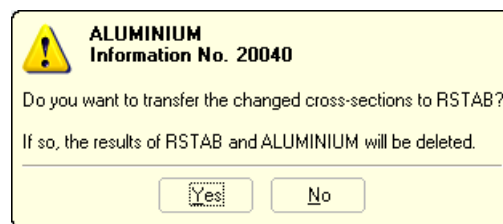

Figure 7.7: Question before transferring modified cross-sections to RSTAB

In a similar way, you can reload the original cross-sections from RSTAB to ALUMINIUM by using the appropriate functions in the main menu or context menu. Please note that this option is only available in table 1.3 *Cross-sections*.

7.3 Import and Export of Materials

If you change a material in table 1.2 of ALUMINIUM, you can export it to RSTAB like cross-sections or also reload the original material from RSTAB to the module. The materials that have been modified in the module are marked in blue color.

It is not necessary to transfer the modified materials to RSTAB manually. Instead, open table 1.2 *Materials* and choose in the main menu

Edit → Export all Materials to RSTAB.

The option to export modified materials to RSTAB is also included in the context menu of table 1.2.

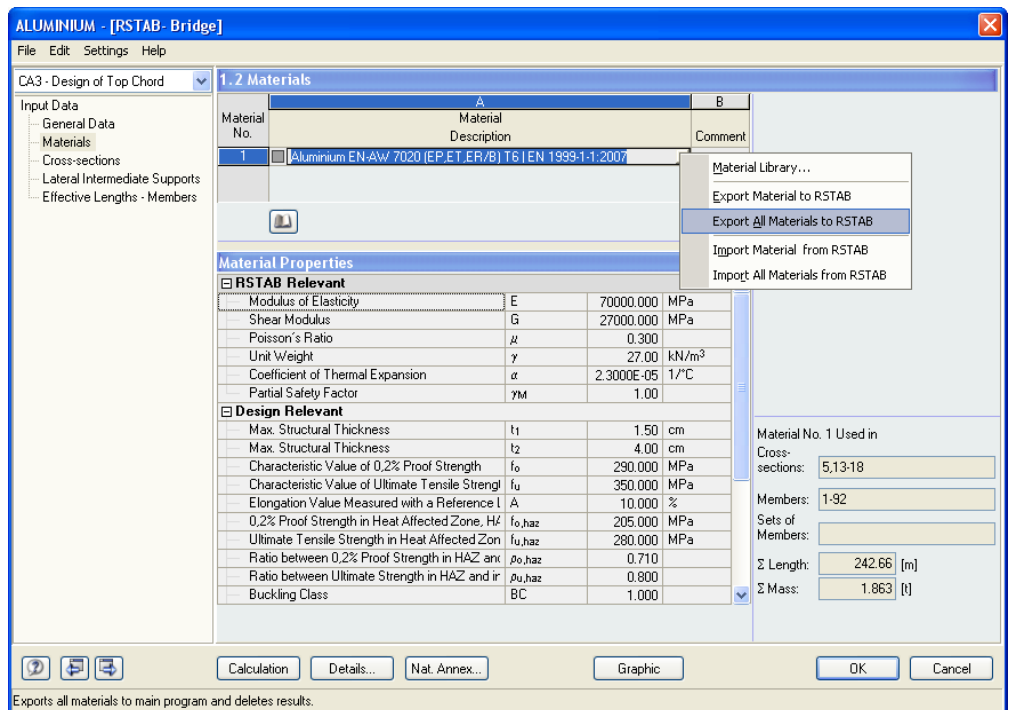

Figure 7.8: Context menu in table 1.2 *Materials*

Calculation

Before the materials are transferred to RSTAB, a question is shown because exporting also implies deleting the results. If you then start the [Calculation] in ALUMINIUM, the internal forces of RSTAB and the design ratios of ALUMINIUM are determined in one calculation run.

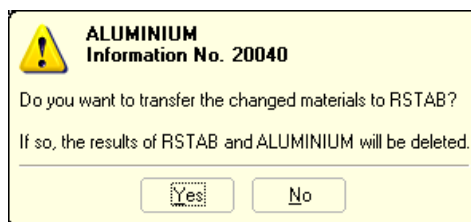

Figure 7.9: Query before transferring modified materials to RSTAB

7.4 Units and Decimal Places

The units and decimal places are centrally managed for RSTAB and all its add-on modules. In ALUMINIUM, open the dialog box to set the units via the main menu

Settings → Units and Decimal Places...

The familiar RSTAB dialog box opens. The module ALUMINIUM is set by default.

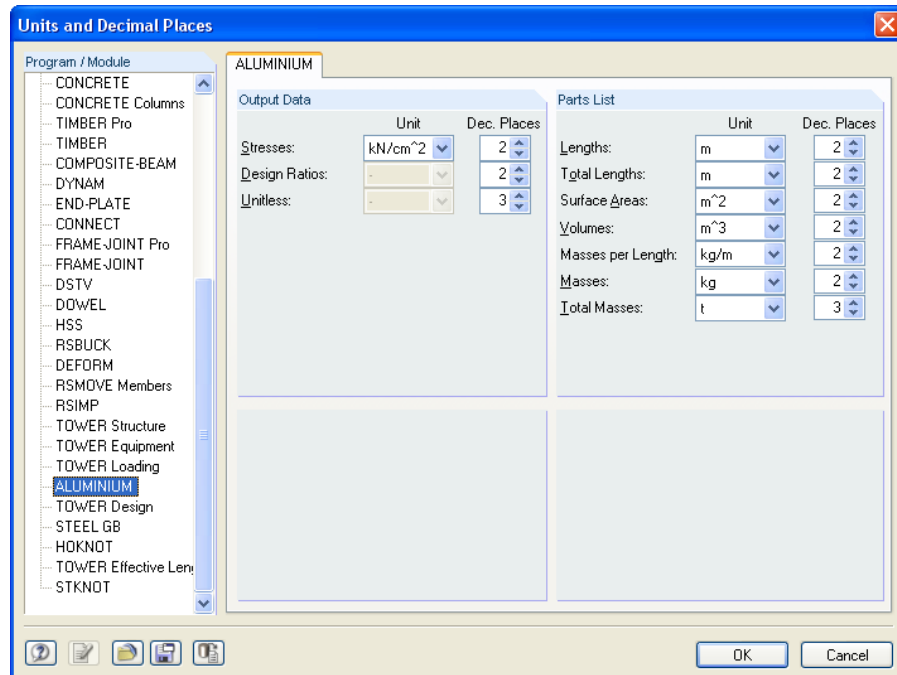

Figure 7.10: Units and Decimal Places dialog box



The settings can be stored as a user profile. They can also be applied later in different cases. This function is described in chapter 11.6.2 of the RSTAB manual.

7.5 Export of Results

The design results can be transferred to other programs in different ways.

Clipboard

Select the relevant cells in the results table of ALUMINIUM and copy them to the clipboard via [Ctrl]+[C]. The contents can then be inserted via [Ctrl]+[V] to e.g. some text processing program. The headers of the table columns are not exported.

Printout Report

The ALUMINIUM data can be sent to the printout report (cf. chapter 6.1, page 48) and then be exported via the main menu

File → Export to RTF File or BauText...

This function is described in chapter 10.1.11 of the RSTAB manual on page 239.

Excel / Open Office

ALUMINIUM enables you to directly export data to MS Excel or OpenOffice.org Calc. Call up this function via the main menu

File → Export Tables...

The following dialog box opens:

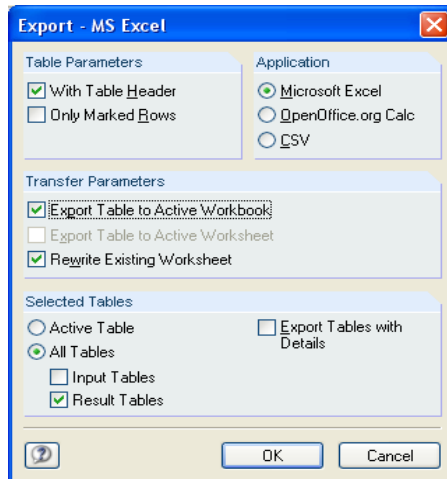

Figure 7.11: Export - MS Excel dialog box

As soon as you have chosen the relevant options, you can start the export by [OK]. Excel or OpenOffice do not need to run in the background, they will be started automatically before the export.

	A	B	C	D	E	F	G
1	Section	Member	Location	Load	Design		
2	No.	No.	x [m]	Case	Ratio		Design according to Formula
3	5	IS 100/80/4/6/0					
4		17	0,424	LG2	0,02 ≤ 1	101)	Cross-Section Check - Tension acc. to 6.2.3
5		41	0,000	LG2	0,17 ≤ 1	106)	Cross-Section Check - Bending Around y-Axis acc. to 6.2.5
6		41	0,000	LG2	0,01 ≤ 1	111)	Cross-Section Check - Shear Force in z-Axis acc. to 6.2.6
7		13	0,000	LG2	0,00 ≤ 1	121)	Cross-Section Check - Shear Buckling acc. to 6.2.6(3)
8		13	0,000	LG2	0,00 ≤ 1	123)	Cross-Section Check - Shear Buckling acc. to 6.2.6(3)
9		4	0,000	LG2	0,14 ≤ 1	129)	Cross-Section Check - Flange Induced Buckling acc. to 6.7.7
10		18	0,000	LG2	0,00 ≤ 1	131)	Cross-Section Check - Torsion acc. to 6.2.7.2
11		26	2,121	LG2	0,01 ≤ 1	132)	Cross-Section Check - Torsion and Shear Force in z-Axis acc. to 6.2.7.3
12		41	0,000	LG2	0,17 ≤ 1	141)	Cross-Section Check - Bending and Shear Force acc. to 6.2.5 and 6.2.8
13		41	0,000	LG2	0,17 ≤ 1	150)	Cross-Section Check - Bending, Shear Force and Torsion acc. to 6.7 - Plate girders
14		15	0,429	LG2	0,08 ≤ 1	171)	Cross-Section Check - Bending, Shear and Axial Force acc. to 6.2.9
15		26	2,121	LG2	0,11 ≤ 1	176)	Cross-Section Check - Bending, Shear, Torsion and Axial Force acc. to 6.2.9
16		39	2,121	LG2	0,10 ≤ 1	180)	Cross-Section Check - Bending, Shear, Axial Force and Torsion acc. to 6.7 - Plate girders
17		15	0,000	LG2	0,10 ≤ 1	191)	Cross-Section Check - Biaxial Bending, Shear and Axial Force acc. to 6.2.10 and 6.2.9
18		41	0,000	LG2	0,28 ≤ 1	321)	Stability Analysis - Lateral-Torsional Buckling acc. to 6.3.2.1 and 6.3.2.3 - I-Profil
19		5	0,000	LG2	0,19 ≤ 1	331)	Stability Analysis - Bending Around y-Axis and Compression acc. to 6.3.3
20							
21	13	IS 300/120/10/15/0					
22		21	0,300	LG2	0,01 ≤ 1	106)	Cross-Section Check - Bending Around y-Axis acc. to 6.2.5
23		21	3,000	LG2	0,00 ≤ 1	111)	Cross-Section Check - Shear Force in z-Axis acc. to 6.2.6
24		48	0,000	LG2	0,00 ≤ 1	113)	Cross-Section Check - Shear Force in y-Axis acc. to 6.2.6
25		8	3,000	LG2	0,00 ≤ 1	121)	Cross-Section Check - Shear Buckling acc. to 6.2.6(3)
26		8	3,000	LG2	0,00 ≤ 1	123)	Cross-Section Check - Shear Buckling acc. to 6.2.6(3)
27		34	0,000	LG2	0,16 ≤ 1	129)	Cross-Section Check - Flange Induced Buckling acc. to 6.7.7

Figure 7.12: Results in MS Excel

8. Example

Column with Biaxial Bending

In the following example, the decisive stability design of buckling and lateral buckling is carried out by analyzing the relevant interaction conditions.

Design Values

Structure and Loads

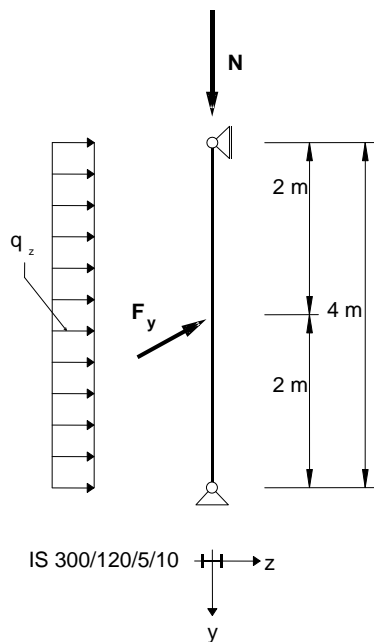

Design values of static loads:

$$\begin{aligned} N_d &= 16 \text{ kN} \\ q_{z,d} &= 4 \text{ kN/m} \\ F_{y,d} &= 2 \text{ kN} \end{aligned}$$

Cross-section: IS 300/120/5/10

Material: EN-AW 6005A (EP/O, ER/B) T6

$$\begin{aligned} \text{Lengths: } L_{cr,y} &= 4 \text{ m} \\ L_{cr,z} &= 4 \text{ m} \\ L_W &= 4 \text{ m} \\ L_T &= 4 \text{ m} \end{aligned}$$

Figure 8.1: Structure and design loads (γ -fold)

Internal Forces according to Linear Static Analysis

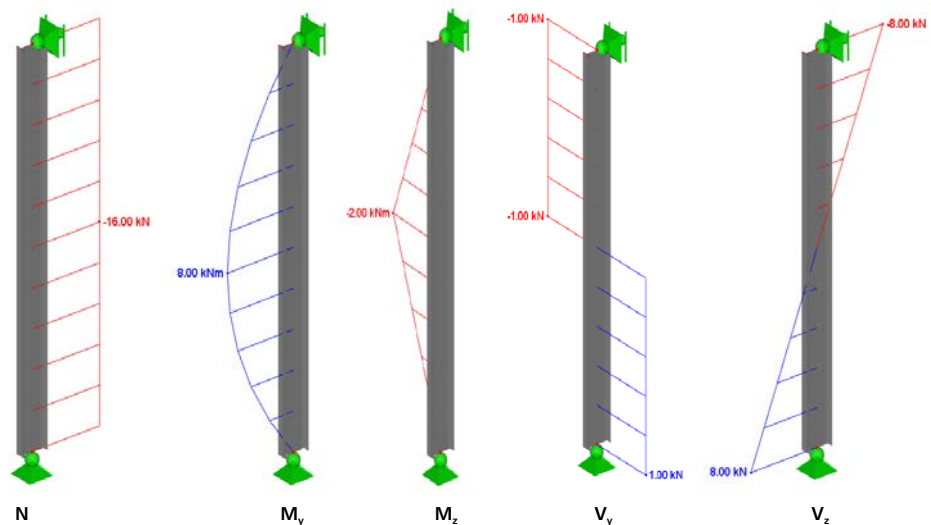

Figure 8.2: Internal forces

Design Location (Decisive Location x)

The design proceeds according to locations x , i.e. on defined locations x of the equivalent member. The following internal forces are determined for the decisive location $x = 2.00$ m:

$$N = -16.00 \text{ kN} \quad M_y = 8.00 \text{ kNm} \quad M_z = 2.00 \text{ kNm} \quad V_y = 1.00 \text{ kN} \quad V_z = 0.00 \text{ kN}$$

Cross-Section Properties IS 300/150/4/8, EN-AW 6005A

Cross-Section Value Description	Symbol	Value	Units
Cross-section area	A	3800	mm ²
Moment of inertia	I_y	59626700	mm ⁴
Moment of inertia	I_z	2882920	mm ⁴
Radius of inertia	i_y	125.265	mm
Radius of inertia	i_z	27.544	mm
Polar radius of inertia	I_0	128.257	mm
Cross-section weight	G	10.3	kg/m
Moment of torsional rigidity	J	87883.6	mm ⁴
Warping moment of inertia	I_{ω}	60552000000	mm ⁶
Cross-section modulus	S_y	397511	mm ³
Cross-section modulus	S_z	48048	mm ³
Plastic cross-section modulus	$Z_{pl,y}$	446000	mm ³
Plastic cross-section modulus	$Z_{pl,z}$	73750	mm ³

Classification of Cross-Section

As specified in EN 1999-1-1, 6.3.3 Notes 1 and 2, cross-sections with combined bending and axial force are to be classified separately for each loading component according to clause 6.1.4. A cross-section can belong to different classes for axial force, bending around major axis and bending around minor axis.

Limit Slenderness Parameters according to [1], Table 6.2

Buckling class for EN-AW 6005A is A(1).

Web (Internal Part - I)

$$\frac{\beta_{w,1}}{\varepsilon_w} = 11 \quad \frac{\beta_{w,2}}{\varepsilon_w} = 16 \quad \frac{\beta_{w,3}}{\varepsilon_w} = 22$$

Material properties for $t_w = 5$ mm

$$f_{o,w} = 225 \text{ MPa} \quad f_{u,w} = 270 \text{ MPa} \quad \text{BC} = \text{A}(1)$$

Material factor

$$\varepsilon_w = \sqrt{250 / f_{o,w}} = \sqrt{250 / 225} = 1.054$$

Flange (Symmetrical Outstanding Part - SO)

$$\frac{\beta_{f,1}}{\varepsilon_f} = 3 \quad \frac{\beta_{f,2}}{\varepsilon_f} = 4.5 \quad \frac{\beta_{f,3}}{\varepsilon_f} = 6$$

Material properties for $t_f = 10$ mm

$$f_{o,f} = 215 \text{ MPa} \quad f_{u,f} = 260 \text{ MPa} \quad \text{BC} = \text{A}(1)$$

Material factor

$$\varepsilon_f = \sqrt{250 / f_{o,f}} = \sqrt{250 / 215} = 1.078$$

Compression Axial Force N_c

$$\sigma_{N_c} = -4.21 \text{ MPa}$$

Web (Internal Part - I)

Slenderness parameter - flat internal part with no stress gradient, cl. 6.1.4.3 a), eq. (6.1)

$$\beta_{w,N_c} = \frac{c_w}{t_w} = \frac{280}{5} = 56$$

$$\beta_{w,N_c} > \beta_{w,3}$$

$$\beta_{w,N_c} > \frac{\beta_{w,3}}{\varepsilon_w} \cdot \varepsilon_w = 22 \cdot 1.054 = 23.19 \Rightarrow \text{Class 4}$$

Flange (Symmetrical Outstanding Part - SO)

Slenderness parameter - flat outstands with no stress gradient, cl. 6.1.4.3 a), eq. (6.1)

$$\beta_{f,N_c} = \frac{c_f}{t_f} = \frac{57.5}{10} = 5.75$$

$$\beta_{f,N_c} \leq \beta_{f,3}$$

$$\beta_{f,N_c} \leq \frac{\beta_{f,3}}{\varepsilon_f} \cdot \varepsilon_f = 6 \cdot 1.078 = 6.47 \Rightarrow \text{Class 3}$$

Bending M_y about Major Axis (y-y Axis)

Web (Internal Part - I)

Stresses at the web edges

$$\sigma_{w,A,M_y} = -18.78 \text{ MPa}$$

$$\sigma_{w,B,M_y} = 18.78 \text{ MPa}$$

Stress ratio

$$\Psi_{w,M_y} = \frac{\sigma_{w,B,M_y}}{\sigma_{w,A,M_y}} = \frac{18.78}{-18.78} = -1.000$$

Stress gradient - eq. (6.4)

$$\eta_{w,M_y} = 0.7 + 0.3\Psi_{w,M_y} = 0.7 + 0.3 \cdot -1.000 = 0.400$$

Slenderness parameter - flat internal part with a stress gradient that results in a neutral axis at the center, cl. 6.1.4.3 b), eq. (6.2) or (6.3)

$$\beta_{w,M_y} = \eta_{w,M_y} \cdot \frac{c_w}{t_w} = 0.400 \cdot \frac{280}{5} = 22.4$$

$$\beta_{w,M_y} \leq \beta_{w,3}$$

$$\beta_{w,M_y} \leq \frac{\beta_{w,3}}{\varepsilon_w} \cdot \varepsilon_w = 22 \cdot 1.054 = 23.19 \Rightarrow \text{Class 3}$$

Flange (Symmetrical Outstanding Part - SO)

Stresses at the flange edges

$$\text{Root} \quad \sigma_{f,A,My} = -20.13 \text{MPa}$$

$$\text{Toe} \quad \sigma_{f,B,My} = -20.13 \text{MPa}$$

Stress ratio

$$\Psi_{f,My} = \frac{\sigma_{f,A,My}}{\sigma_{f,B,My}} = \frac{-20.13}{-20.13} = 1.000$$

Slenderness parameter - flat outstands with no stress gradient, cl. 6.1.4.3 a), eq. (6.1)

$$\beta_{f,My} = \frac{c_f}{t_f} = \frac{57.5}{10} = 5.75$$

Bending M_z about Minor Axis (z-z Axis)**Web (Internal Part - I)**

Stresses at the web edges

$$\sigma_{w,A,Mz} = \sigma_{w,B,Mz} = 0 \text{MPa} \Rightarrow \text{No compression at the web}$$

Flange (Symmetrical Outstanding Part - SO)

Stresses at the flange edges

$$\text{Root} \quad \sigma_{f,A,Mz} = -1.73 \text{MPa}$$

$$\text{Toe} \quad \sigma_{f,B,Mz} = -41.62 \text{MPa}$$

Slenderness parameter - flat outstands with peak compression at toe, cl. 6.1.4.3 a), eq. (6.1)

$$\beta_{f,Mz} = \frac{c_f}{t_f} = \frac{57.5}{10} = 5.75$$

$$\beta_{f,Mz} \leq \beta_{f,3}$$

$$\beta_{f,Mz} \leq \frac{\beta_{f,3}}{\varepsilon_f} \cdot \varepsilon_f = 6 \cdot 1.078 = 6.47 \Rightarrow \text{Class 3}$$

Effective Cross-Section Properties**Effective Cross-Section Area (Class 4 for Axial Load N_c)****Web (Internal Part - I)**

Reduction factor, cl. 6.1.5(2), eq. (6.12)

$$\rho_{c,w,Nc} = \frac{C_1}{(\beta_{w,Nc} / \varepsilon_w)} - \frac{C_2}{(\beta_{w,Nc} / \varepsilon_w)^2} = \frac{32}{(56 / 1.054)} - \frac{220}{(56 / 1.054)^2} = 0.524$$

Reduced thickness of web

$$t_{c,w,Nc} = \rho_{c,w,Nc} \cdot t_w = 0.524 \cdot 5 = 2.622 \text{mm}$$

Reduced area of web

$$A_{w,eff,Nc} = t_{c,w,Nc} \cdot c_w = 2.622 \cdot 280 = 734.16 \text{mm}^2$$

Flange (Symmetrical Outstanding Part - SO)

Class 3 - no reduction, cl. 6.1.5(2), eq. (6.11)

$$\rho_{c,f,Nc} = 1.000 \quad t_{c,f,Nc} = t_f = 10\text{mm}$$

Area of flanges

$$A_f = 2 \cdot A_{f,1} = 2 \cdot t_f \cdot c_f = 2 \cdot 10 \cdot 120 = 2400\text{mm}^2$$

Effective area of whole cross-section

$$A_{\text{eff}} = A_w + A_f = 734.16 + 2400 = 3134.16\text{mm}^2$$

Buckling around Major Axis (\perp to y-y Axis)

Elastic critical force for flexural buckling according to [1], Annex I.3, eq. (I.15)

$$N_{cr,y} = \frac{\pi^2 E I_y}{L_{cr,y}^2} = \frac{\pi^2 \cdot 70000 \cdot 59626700}{4000^2} = 2574652 \text{ N} = 2574.65 \text{ kN}$$

Relative slenderness for flexural buckling, cl. 6.3.1.2(1), eq. (6.51)

$$\bar{\lambda}_y = \sqrt{\frac{A \cdot f_o}{N_{cr,y}}} = \sqrt{\frac{3800 \cdot 215}{2574652}} = 0.512$$

Limit of horizontal plateau of buckling curve and imperfection factor, table 6.6

Material buckling class according to table 3.2 A(1) $\Rightarrow \bar{\lambda}_{y,0} = 0.100 \quad \alpha_y = 0.200$

Conditions for ignoring buckling effects, cl. 6.3.1.2(4)

$$\bar{\lambda}_y > \bar{\lambda}_{y,0} \quad 0.512 > 0.100$$

$$N_{Ed} > \bar{\lambda}_{y,0}^2 N_{cr,y} \quad 16 > 0.010 \cdot 2574.652 = 25.746$$

According to 2nd condition, it is not necessary to carry out the buckling design for y-y axis.

Auxiliary factor, cl. 6.3.1.2(1), eq. (6.51)

$$\phi_y = 0.5 \cdot [1 + \alpha_y \cdot (\bar{\lambda}_y - \bar{\lambda}_{y,0}) + \bar{\lambda}_y^2] = 0.5 \cdot [1 + 0.2 \cdot (0.512 - 0.1) + 0.512^2] = 0.672$$

Reduction factor, cl. 6.3.1.2(1), eq. (6.50)

$$\chi_y = \frac{1}{\phi_y + \sqrt{\phi_y^2 - \bar{\lambda}_y^2}} = \frac{1}{0.672 + \sqrt{0.672^2 - 0.512^2}} = 0.903$$

Result Values of Design in ALUMINIUM

Moment of inertia	I_y	59626700	mm ⁴		
Effective length of member	$L_{cr,y}$	4.000	m		
Elastic critical force	$N_{cr,y}$	2574.65	kN		
Relative slenderness	$\bar{\lambda}_{bar,y}$	0.512		> 0.1	6.3.1.2(4)
Buckling stress curve	BSC_y	A(1)			Table 3.2b
Imperfection factor	α_y	0.200			Table 6.6
Auxiliary factor	ϕ_y	0.672			Eq. (6.51)
Reduction factor	χ_y	0.903			Eq. (6.50)

Buckling around Minor Axis (\perp to z-z Axis)

Elastic critical force for flexural buckling according to [1], Annex I.3, eq. (I.15)

$$N_{cr,z} = \frac{\pi^2 E I_z}{L_{cr,z}^2} = \frac{\pi^2 \cdot 70000 \cdot 2882920}{4000^2} = 124483.1 \text{ N} = 124.483 \text{ kN}$$

Relative slenderness for flexural buckling, cl. 6.3.1.2(1), eq. (6.51)

$$\bar{\lambda}_z = \sqrt{\frac{A \cdot f_o}{N_{cr,z}}} = \sqrt{\frac{3800 \cdot 215}{124483.1}} = 2.327$$

Limit of horizontal plateau of buckling curve and imperfection factor, table 6.6

Material buckling class according to [1], table 3.2 A(1) $\Rightarrow \bar{\lambda}_{z,0} = 0.100 \quad \alpha_z = 0.200$

Conditions for ignoring of buckling effects, cl. 6.3.1.2(4)

$$\bar{\lambda}_z > \bar{\lambda}_{z,0} \quad 2.327 > 0.100$$

$$N_{Ed} > \bar{\lambda}_{z,0}^2 N_{cr} \quad 16 > 0.010 \cdot 124.483 = 1.245$$

It is necessary to carry out the buckling design.

Auxiliary factor, cl. 6.3.1.2(1), eq. (6.51)

$$\phi_z = 0.5 \cdot [1 + \alpha_z \cdot (\bar{\lambda}_z - \bar{\lambda}_{z,0}) + \bar{\lambda}_z^2] = 0.5 \cdot [1 + 0.2 \cdot (2.327 - 0.1) + 2.327^2] = 3.429$$

Reduction factor, cl. 6.3.1.2(1), eq. (6.50)

$$\chi_z = \frac{1}{\phi_z + \sqrt{\phi_z^2 - \bar{\lambda}_z^2}} = \frac{1}{3.429 + \sqrt{3.429^2 - 2.327^2}} = 0.168$$

Design buckling resistance, cl. 6.3.1.1(2), eq. (6.49)

$$N_{b,Rd,z} = \kappa \cdot \chi_z \cdot A_{eff} \cdot f_o / \gamma_{M1} = 1.000 \cdot 0.168 \cdot 3134.1 \cdot 215 / 1.1 = 102982.3 \text{ N} = 102.98 \text{ kN}$$

κ - factor for the weakening effects of welding, no welds are allowed, therefore $\kappa = 1.000$

Design ratio, cl. 6.3.1.1(1), eq. (6.48)

$$\frac{N_{Ed}}{N_{b,Rd,z}} = \frac{16}{102.98} = 0.155$$

Result Values of Design in ALUMINIUM

Moment of inertia	I_z	2882920	mm ⁴		
Effective length of member	$L_{cr,z}$	4.000	m		
Elastic critical force	$N_{cr,z}$	124.48	kN		
Relative slenderness	$\lambda_{bar,z}$	2.327		> 0.1	6.3.1.2(4)
Buckling stress curve	BSC_z	A(1)			Table 3.2b
Imperfection factor	α_z	0.200			Table 6.6
Auxiliary factor	ϕ_z	3.429			Eq. (6.51)
Reduction factor	χ_z	0.168			Eq. (6.50)

Torsional Buckling around Longitudinal Axis (around x-x Axis)

Elastic critical force for torsional buckling according to [1], Annex I.3, eq. (I.16)

$$N_{cr,T} = \frac{1}{i_s^2} \left[G I_t + \frac{\pi^2 E I_w}{L_T^2} \right]$$

$$N_{cr,T} = \frac{1}{128.257^2} \left[27000 \cdot 87883.6 + \frac{\pi^2 70000 \cdot 60552000000}{4000^2} \right] = 303191.1 \text{ N} = 303.191 \text{ kN}$$

Relative slenderness for torsional buckling, cl. 6.3.1.4(2), eq. (6.53)

$$\bar{\lambda}_T = \sqrt{\frac{A_{eff} \cdot f_o}{N_{cr,T}}} = \sqrt{\frac{3134.1 \cdot 215}{303191.1}} = 1.491$$

Limit of horizontal plateau of buckling curve, imperfection factor and governing cross-section area, table 6.7

General cross-section shape $\Rightarrow \bar{\lambda}_{T,0} = 0.400$ $\alpha_T = 0.350$ use A_{eff}

Condition to ignore buckling effects, cl. 6.3.1.4(1), NOTE b) doubly symmetrical I-sections

\Rightarrow Not necessary to carry out torsional buckling design.

Lateral Torsional Buckling

Elastic Critical Moment for Lateral Torsional Buckling

The elastic critical moment M_{cr} for lateral-torsional buckling is calculated according to [1], Annex I.1.

The assumption is based on a hinged support without the restriction of warping. The point of load application is assumed in the shear center. This location can be modified in the detailed settings for transversal loads (see Figure 3.2, page 28).

For the simply supported beam with no warping restraint, the buckling length factors can be applied according to [1], cl. I.1.1(2) - standard conditions of restraint:

$$k_y = 1.00 \quad k_z = 1.00 \quad k_w = 1.00$$

[1], cl. I.1.1(1), eq. (I.1) specifies the determination of the elastic critical moment of a beam of uniform symmetrical cross-section with equal flanges, under standard restraint conditions and subject to uniform moment in plane going through the shear center.

$$M_{cr,0} = \frac{\pi^2 \cdot E \cdot I_z}{L^2} \cdot \sqrt{\frac{L^2 \cdot G \cdot I_t + I_\omega}{\pi^2 \cdot E \cdot I_z}} = \frac{\pi \sqrt{E I_z G I_t}}{L} \sqrt{1 + \frac{\pi^2 E I_\omega}{L^2 G I_t}}$$

$$M_{cr,0} = \frac{\pi \sqrt{70000 \cdot 288292 \cdot 27000 \cdot 87883.6}}{4000} \sqrt{1 + \frac{\pi^2 70000 \cdot 6.0552e + 10}{4000^2 \cdot 27000 \cdot 87883.6}}$$

$$M_{cr,0} = 24916960 \text{ Nmm} = 24.916 \text{ kNm}$$

Next, the the elastic critical moment as stated in clauses I.1.2 and I.1.3 is calculated which is required to determine the slendernesses.

The values of the constants $C_{1,0}$ and $C_{1,1}$ are given in table I.2 (1st row - uniform loading).

$$C_{1,0} = 1.127 \quad C_{1,1} = 1.132$$

For equal flanges is according to eq. (I.4b): $\psi_f = \frac{I_{fc} - I_{ft}}{I_{fc} + I_{ft}} = 0 \Rightarrow C_2 = 0.459$

Non-dimensional torsion parameter

$$\kappa_{wt} = \frac{\pi}{k_w L} \cdot \sqrt{\frac{E I_\omega}{G I_t}} = \frac{\pi}{1 \cdot 4000} \cdot \sqrt{\frac{70000 \cdot 6.0552e + 10}{27000 \cdot 87883.6}} = 1.050$$

Constant C_1

$$C_1 = C_{1,0} + (C_{1,1} - C_{1,0}) \kappa_{wt} \leq C_{1,1}$$

$$C_1 = 1.127 + (1.132 - 1.127) \cdot 1.050 = 1.132$$

Relative non-dimensional critical moment of doubly symmetric section for transverse loads applied at the shear center ($z_f = 0, z_g = 0$), cl. I.1.3(2), eq. (I.8)

$$\mu_{cr} = \frac{C_1}{k_z} \cdot \sqrt{1 + \kappa_{wt}^2} = \frac{1.132}{1.00} \cdot \sqrt{1 + 1.050^2} = 1.641$$

Elastic critical moment, cl. I.1.2(2), eq. (I.2)

$$M_{cr} = \mu_{cr} \frac{\pi \sqrt{E I_z G I_t}}{L} = 1.641 \frac{\pi \sqrt{70000 \cdot 288292 \cdot 27000 \cdot 87883.6}}{4000}$$

$$M_{cr} = 28205999 \text{ Nmm} = 28.21 \text{ kNm}$$

The elastic critical moment for slenderness determination can also be calculated according to the transformed equation:

$$M_{cr} = C_1 \frac{\pi^2 \cdot E \cdot I_z}{L^2} \cdot \sqrt{\frac{L^2 \cdot G \cdot I_t + I_\omega}{\pi^2 \cdot E \cdot I_z}} = C_1 \frac{\pi \sqrt{E I_z G I_t}}{L} \sqrt{1 + \frac{\pi^2 E I_\omega}{L^2 G I_t}}$$

$$M_{cr} = 1.132 \frac{\pi \sqrt{70000 \cdot 288292 \cdot 27000 \cdot 87883.6}}{4000} \sqrt{1 + \frac{\pi^2 70000 \cdot 6.0552e + 10}{4000^2 \cdot 27000 \cdot 87883.6}}$$

$$M_{cr} = 28205999 \text{ Nmm} = 28.21 \text{ kNm}$$

The program also calculates $M_{cr,0}$, based on the assumption that the moment diagram is constant.



Note: In the results for simple bending about major axis or for sets of members, $M_{cr,x}$ is displayed for the location x in question. It is the elastic critical moment at lateral buckling at this x -location, related to the critical moment at lateral buckling at the location of the maximum moment. The comparative slenderness at lateral buckling $\bar{\lambda}_{LT}$ is calculated from the moment $M_{cr,x}$.

Comparative Slenderness at Lateral Torsional Buckling

The calculation is based on clauses 6.3.2.3 or I.2 for the location of the maximum moment at $x = 2.0$ m.

IS 300/150/4/8, cross-section of class 3 for bending around y - y : $W_y = W_{el,y} = 397511 \text{ mm}^3$

The formula for the shape factor α is given in table 6.4.

$$\alpha_y = \frac{W_{el,y}}{W_{el,y}} = \frac{397511}{397511} = 1.000 \leq 1.250$$

Relative slenderness, cl. 6.3.2.3(1), eq. (6.58)

$$\bar{\lambda}_{LT} = \sqrt{\frac{\alpha W_{el,y} \cdot f_o}{M_{cr}}} = \sqrt{\frac{1 \cdot 397511 \cdot 215}{28205999}} = 1.741$$

Lateral Buckling Coefficient χ_{LT}

The calculation is based on cl. 6.3.2.2.

The lateral buckling curve depends on the cross-section class and it is given by cl. 6.3.2.2(2).

Class for M_y : 3 \Rightarrow Lateral buckling curve „2“ $\Rightarrow \bar{\lambda}_{0,LT} = 0.400$ $\alpha_{LT} = 0.200$

Auxiliary factor, cl. 6.3.2.2(1), eq. (6.57)

$$\Phi_{LT} = 0.5 \cdot [1 + \alpha_{LT} \cdot (\bar{\lambda}_{LT} - \bar{\lambda}_{0,LT}) + \bar{\lambda}_{LT}^2] = 0.5 \cdot [1 + 0.2 \cdot (1.741 - 0.4) + 1.741^2] = 2.149$$

Reduction factor, cl. 6.3.2.2(1), eq. (6.56)

$$\chi_{LT} = \frac{1}{\Phi_{LT} + \sqrt{\Phi_{LT}^2 - \bar{\lambda}_{LT}^2}} = \frac{1}{2.149 + \sqrt{2.149^2 - 1.741^2}} = 0.293$$

Design buckling resistance moment, cl. 6.3.2.1(2), eq. (6.55)

$$M_{b,Rd} = \chi_{LT} \cdot \alpha_y \cdot W_{el,y} \cdot f_o / \gamma_{M1} = 0.293 \cdot 1.000 \cdot 397511 \cdot 215 / 1.100 = 22788229 \text{ Nmm}$$

Bending and Axial Compression

Interaction Exponents ξ_{yc} , ξ_{zc} , η_c and γ_c

The interaction exponents are given by cl. 6.3.3.1(1), eq. (6.61a) to (6.61e). The standard gives default values, but alternative values can also be calculated. In the example, the default values of exponents are used. For γ_0 , see cl. 6.2.9.1(1), eq. (6.42b).

$$\eta_c = 0.80 \quad \xi_{yc} = 0.80 \quad \xi_{zc} = 0.80 \quad \gamma_c = \gamma_0 = 1.00$$

HAZ softening Factors ω_0 , ω_x and ω_{xLT}

Welds are not implemented in the current program version. Therefore, the values of these factors are set to 1.00 as for sections without localized welds (cf. cl. 6.2.9.1(1)). For more information on the factors, see clauses 6.3.3.3 to 6.3.3.5.

$$\omega_0 = \omega_x = \omega_{xLT} = 1.00$$

Design Resistances N_{Rd} , $M_{y,Rd}$, $M_{z,Rd}$

The design resistances are calculated according to clauses 6.3.3.1(5) and 6.3.3.2(1).

$$N_{Rd} = \kappa \cdot A_{eff} \cdot f_o / \gamma_{M1} = 1.000 \cdot 3134.1 \cdot 215 / 1.100 = 612583N = 612.583kN$$

The formula for the shape factor α is given in table 6.4.

$$\alpha_y = \frac{W_{el,y}}{W_{pl,y}} = \frac{397511}{397511} = 1.000 \leq 1.25 \quad \alpha_z = \frac{73750}{73750} = 1.000 \leq 1.25$$

Bending moment capacity about y-axis

$$M_{y,Rd} = \alpha_y \cdot W_{y,el} \cdot f_o / \gamma_{M1} = 1.000 \cdot 397511 \cdot 215 / 1.100 = 77695332Nmm = 77.695kNm$$

Bending moment capacity about z-axis

$$M_{z,Rd} = \alpha_z \cdot W_{z,el} \cdot f_o / \gamma_{M1} = 1.000 \cdot 48049 \cdot 215 / 1.100 = 9391317Nmm = 9.391kNm$$

Flexural Buckling according to [1], clause 6.3.3.1

Interaction Design for Buckling around Major Axis and Bending M_y

$$\left(\frac{N_{Ed}}{\chi_y \cdot \omega_{x,y} \cdot N_{Rd}} \right)^{\xi_{yc}} + \frac{M_{y,Ed}}{\omega_0 \cdot M_{y,Rd}} \leq 1.00 \quad \text{eq. (6.59)}$$

$$\left(\frac{16}{0.903 \cdot 1.00 \cdot 612.583} \right)^{0.8} + \frac{8}{1.00 \cdot 77.695} \leq 1.00$$

$$0.059 + 0.103 = 0.162 \leq 1.00$$

Interaction Design for Buckling around Minor Axis and Bending M_z

$$\left(\frac{N_{Ed}}{\chi_z \cdot \omega_{x,z} \cdot N_{Rd}} \right)^{\eta_c} + \frac{M_{z,Ed}}{\omega_0 \cdot M_{z,Rd}} \leq 1.00 \quad \text{eq. (6.60)}$$

$$\left(\frac{16}{0.168 \cdot 1.00 \cdot 612.583} \right)^{0.8} + \frac{2}{1.00 \cdot 9.391} \leq 1.00$$

$$0.225 + 0.29 = 0.516 \leq 1.00$$

Lateral-Torsional Buckling according to [1], clause 6.3.3.2

$$\left(\frac{N_{Ed}}{\chi_z \cdot \omega_{x,z} \cdot N_{Rd}}\right)^{\eta_c} + \left(\frac{M_{y,Ed}}{\chi_{LT} \cdot \omega_{x,LT} \cdot M_{y,Rd}}\right)^{\gamma_c} + \left(\frac{M_{z,Ed}}{\omega_0 \cdot M_{z,Rd}}\right)^{\xi_{z,c}} \leq 1.00 \quad \text{eq. (6.63)}$$

$$\left(\frac{16}{0.168 \cdot 1.00 \cdot 612.583}\right)^{0.8} + \left(\frac{8}{0.293 \cdot 1.00 \cdot 77.695}\right)^{1.0} + \left(\frac{2}{1.00 \cdot 9.391}\right)^{0.8} \leq 1.00$$

$$0.225 + 0.351 + 0.29 = 0.867 \leq 1.00$$



Notes: In the equations (6.59) and (6.60) for flexural buckling, χ_y and χ_z are the reduction factors for buckling in the z-x plane resp. y-x plane.

In equation (6.63) for lateral-torsional buckling, χ_z represents the reduction factor for buckling when one or both flanges deflects laterally (buckling in the y-x plane or lateral-torsional buckling).

Result Values of Design in ALUMINIUM

Ideal Torsional Buckling Load	$N_{cr,T}$	303.19	kN		Eq. (I.16)
Modulus of Elasticity	E	7000.0	kN/cm ²		3.2.5(1)
Second Moment of Area	I_y	59626700	mm ⁴		
Effective Member Length	$L_{cr,y}$	4000.0	mm		
Elastic Flexural Buckling Force	$N_{cr,y}$	2574.65	kN		Eq. (I.14)
Second Moment of Area	I_z	2882920	mm ⁴		
Effective Member Length	$L_{cr,z}$	4000.0	mm		
Elastic Flexural Buckling Force	$N_{cr,z}$	124.48	kN		Eq. (I.15)
Relative Slenderness	λ_{-z}	2.327		$> \lambda_{-0}$	6.3.1.2(4)
Buckling Curve	BC_z	1			Table 6.6
Imperfection Factor	α_z	0.200			Table 6.6
Auxiliary Factor	ϕ_z	3.429			6.3.1.2(1)
Reduction Factor	χ_z	0.168			Eq. (6.50)
Cross-section Area	A	3800.0	mm ²		
Characteristic Proof Strength	f_0	21.50	kN/cm ²		Table 3.2.1
Buckling Curve	BC_{LT}	2			6.3.2.2(2)
Imperfection Factor	α_{LT}	0.200			6.3.2.2(2)
Shear Modulus	G	2700.0	kN/cm ²		3.2.5(1)
Length Factor	k_z	1.000			
Length Factor	k_w	1.000			
Length	L	4000.0	mm		
Warping Constant of Cross-section	I_w	6.0552E+10	mm ⁶		
Torsional Constant	I_t	87883.6	mm ⁴		
Ideal Elastic Critical Moment	$M_{cr,0}$	24.92	kNm		
Ideal Elastic Critical Moment for Lateral-Torsional Buckling	M_{cr}	28.19	kNm		

Moment Factor	C_1	1.131			Eigenvalue Solution
Modulus of Cross-section	W_y	397511	mm ³		
Relative Slenderness	λ_{-LT}	1.741			6.3.2.3
Auxiliary Factor	ϕ_{LT}	2.150			6.3.2.2(1)
Reduction Factor	χ_{LT}	0.293			Eq. (6.56)
Ideal Torsional Buckling Load	$N_{cr,T}$	303.19	kN		Eq. (I.16)
Axial Force (Compression)	N_{Ed}	16.00	kN		
HAZ-softening Factor	$\omega_{x,y}$	1.000			6.3.3
HAZ-softening Factor	$\omega_{x,z}$	1.000			
Exponent	ξ_{sync}	0.800			6.3.3
Exponent	ξ_{zsc}	0.800			6.3.3
HAZ-softening Factor	ω_0	1.000			6.2.9 or 6.3.3
HAZ-softening Factor	ω_{xLT}	1.000			6.3.3
Exponent	ω_c	1.000			6.3.3
Exponent	η_c	0.800			6.3.3
Governing Cross-section Area	A_{eff}	3134.15	mm ²		
Axial Force Resistance	N_{Rd}	612.58	kN		Eq. (6.22)
Partial Factor	γ_{M1}	1.100			Table 6.1
Design Component for N	η_{Ny}	0.054		< 1	Eq. (6.59)
Design Component for N	η_{Nz}	0.225		< 1	Eq. (6.60)
Moment	$M_{y,Ed}$	8.00	kNm		
Moment	$\Delta M_{y,Ed}$	0.00	kNm		
Modulus of Cross-section	W_y	397511	mm ³		
Moment Resistance	$M_{y,Rd}$	77.70	kNm		
Moment Component	η_{My}	0.35		< 1	
Moment	$M_{z,Ed}$	2.00	kNm		
Moment	$\Delta M_{z,Ed}$	0.00	kNm		
Modulus of Cross-section	W_z	48048.6	mm ³		
Moment Resistance	$M_{z,Rd}$	9.39	kNm		
Moment Component	η_{Mz}	0.290		< 1	
Design 1	η_1	0.157		< 1	Eq. (6.59)
Design 2	η_2	0.516		< 1	Eq. (6.60)
Design 3	η_3	0.867		< 1	Eq. (6.63)
Design	η	0.867		< 1	

A Literature

- [1] EN 1999-1-1: Design of aluminium structures - Part 1-1: General structural rules, May 2007
- [2] EAA - European Aluminium Association TALAT Lectures:
<http://eaa.net/eaa/education/TALAT/index.htm>

B Index

2	
2 nd Order Theory	29
A	
Alternative Values	27
ALUMINIUM Design Cases	50
Angle	28
B	
Background Graphics	43
Buckling around Axis	19
Buckling Length Coefficient	19, 20
Buckling Possible	19
Buttons	42
C	
Calculation	27
<i>Camber</i>	26
Cantilever Beam	26
Closing ALUMINIUM	8
Color Bars	42
Color Spectrum	46
Colored Stresses	46
Combination of Actions	10
Comment	11
Control Panel	46
Cross-Section Description	14
Cross-Section Library	14, 15
Cross-Section Optimization	52
Cross-Section Parts (c/t)	15
Cross-Sections	14, 28
D	
Decimal Places	12, 55
Deflection	10
Deformation	26
Design	9
Design by Cross-Section	35
Design by Load Cases	34
Design Case	44, 51
Design Ratio	35
Design Situation	35
Details	27
Display	43
Display Hidden Result Diagram	46
<i>Display Navigator</i>	44, 46
Distance x_3	30
E	
Effective Length	18, 20
Effective Slenderness	40
Elastic Critical Moment	29
Elastic Design	27
Evaluation of Results	42
Excel	56
Export Cross-Sections	53
Export Materials	54
Export of Results	55
F	
Filtering of Members	47
Filtering of Results	46
G	
General Data	8
Governing Internal Forces	38, 52
Graph of Results	45
Graphics	43
I	
Installation	5
L	
Lateral Buckling	21
Length	40
Limit Deformation	31
Limit Load	30
Limit Values	10
Load Case	9, 10
Load Combination	10
Location x	35, 37, 38
M	
Material Description	12
Material Library	13
Material Properties	12
Materials	12
Maximum Design Ratio	16

Member Diagrams	45	Serviceability Design	26
Member-like Input	29	Serviceability Limit State	10
Members	9	Set of Members	9, 22, 25, 29, 36, 39, 41
N		SHAPE-THIN	28
National Annex	9, 11	Shifted Member Ends	31
Navigator	8	Slenderness	30, 31, 39
O		Stability	28
OpenOffice	56	Start Calculation	32
Optimization	31, 52	Starting ALUMINIUM	6
Optimize	16	Stresses Rendering	46
P		Sum	41
Panel	7, 44, 46	Surface Area	41
Parameterized Cross-section	52	Switch Tables	8
Part	40	Symmetry Check	31
Partial View	46	T	
Plate Girder	28	Tables	8
Print	48	Tapered Member	15
Print ALUMINIUM Graphics	48	Torsion	30
Printout Report	48	Torsional Buckling	30
Product Form	13	Torsional-Flexural Buckling	30
R		Transverse Load	29
Reference Length	26	U	
Remark	16	Ultimate Limit State	8, 27
Restriction of Warping	21	Undeformed System	31
Result Diagrams	45, 48	Unit Weight	41
Result Values	43	Units	12, 55
Results	43	User Profile	55
Results on RSTAB Model	48	V	
Results Tables	34	View Mode	42, 43
RSBUCK	20	Volume	41
RSTAB Work Window	43	W	
S		Weight	41
Scale Factor	45	Weld	16, 28
Serviceability	30		