

Version
September 2011

Add-on Module

STEEL BS

**Ultimate Limit State and Service-
ability Limit State Design acc. to
BS 5950-1 and BS EN 1993-1-1**

Program Description

All rights, including those of the translation, are reserved.
No portion of this book may be reproduced – mechanically,
electronically, or by any other means, including photocopying –
without written permission of ING. SOFTWARE DLUBAL.

© Ing. Software Dlubal

Am Zellweg 2 D - 93464 Tiefenbach

Tel: +49 (0) 9673 9203-0
Fax: +49 (0) 9673 9203-51
E-mail: info@dlubal.com
Web: www.dlubal.com



Contents

Contents		Page	Contents		Page
1.	Introduction	4	6.	Printout	49
1.1	Additional Module STEEL BS	4	6.1	Printout Report	49
1.2	STEEL BS Team	5	6.2	Print STEEL BS Graphics	49
1.3	Using the Manual	5	7.	General Functions	51
1.4	Starting STEEL BS	6	7.1	STEEL BS Design Cases	51
2.	Input Data	8	7.2	Cross-Section Optimization	53
2.1	General Data	8	7.3	Import / Export of Materials	55
2.1.1	Ultimate Limit State	8	7.4	Units and Decimal Places	56
2.1.2	Serviceability Limit State	10	7.5	Export Results	56
2.1.3	National Annex (NA)	11	8.	Example	58
2.2	Materials	14	A	Literature	67
2.3	Cross-Sections	16	B	Index	68
2.4	Lateral Intermediate Supports	20			
2.5	Effective Lengths - Members	21			
2.6	Effective Lengths - Sets of Members	24			
2.7	Nodal Supports	25			
2.8	Member Releases	27			
2.9	Serviceability Data	28			
3.	Calculation	29			
3.1	Details	29			
3.2	Start Calculation	31			
4.	Results	33			
4.1	Design by Load Case	33			
4.2	Design by Cross-Section	34			
4.3	Design by Set of Members	35			
4.4	Design by Member	35			
4.5	Design by x-Location	36			
4.6	Governing Internal Forces by Member	37			
4.7	Governing Internal Forces by Set of Members	38			
4.8	Member Slendernesses	38			
4.9	Parts List by Member	39			
4.10	Parts List by Set of Members	40			
5.	Evaluation of Results	41			
5.1	Results on RSTAB Model	42			
5.2	Result Diagrams	46			
5.3	Filter Results	47			

1. Introduction

1.1 Additional Module STEEL BS

The British Standard BS 5950-1:2000 determines rules for the design, analysis and construction of steel buildings in the United Kingdom. With the add-on module STEEL BS from the company ING. SOFTWARE DLUBAL all users obtain a highly efficient and universal tool to design steel structures according to this standard. Furthermore, the design can be carried out according to BS EN 1993-1-1:2005 (Eurocode 3) with consideration of the National Annex for the United Kingdom.

All typical designs of load capacity, stability and deformation are carried out in the module STEEL BS. Different actions are taken into account during the load capacity design. The allocation of designed cross-sections into four classes (plastic, compact, semi-compact and slender) makes an important part of the design according to BS 5950-1:2000. The purpose of this classification is to determine the range in which the local buckling in cross-section parts limits the load capacity so that the rotational capacity of cross-sections can be verified. Further, STEEL BS automatically calculates the limiting width-to-thickness ratios of compressed parts and carries out the classification automatically.

For the stability design, you can determine for every single member or set of members whether buckling is possible in the direction of y-axis and/or z-axis. Lateral supports can be added for a realistic representation of the structural model. All comparative slendernesses and critical stresses are automatically determined by STEEL BS on the basis of the boundary conditions. For the design of lateral torsional buckling, the elastic critical stress that is necessary for the design is calculated automatically. The location where the loads are applied, which influences the elastic critical moment, can also be defined in the detailed settings.

The serviceability limit state has become important for the static calculations of modern civil engineering as more and more slender cross-sections are being used. In STEEL BS, load cases and groups and combinations of load cases can be arranged individually to cover the various design situations. The limit deformations can be defined individually.

Like other modules, STEEL BS is fully integrated into the RSTAB 7 program. However, it is not only an optical part of the program. The results of the module can be incorporated to the central printout report. Therefore, the entire design can be easily and especially uniformly organized and presented.

The program includes an automatic cross-section optimization and a possibility to export all modified profiles to RSTAB.

Individual design cases make it possible to flexibly analyze separate parts of extensive structures.

We wish you much success and delight when working with our module STEEL BS.

Your ING. SOFTWARE DLUBAL company.

1.2 STEEL BS Team

The following people participated in the development of the STEEL BS module:

Program Coordinators

Dipl.-Ing. Georg Dlubal

Dipl.-Ing. (FH) Younes El Frem

Ing. Ph.D. Peter Chromiak

Programmers

Ing. Zdeněk Kosáček

Ing. Ph.D. Peter Chromiak

Dipl.-Ing. Georg Dlubal

Dr.-Ing. Jaroslav Lain

Ing. Martin Budáč

Mgr. Petr Oulehle

Ing. Roman Svoboda

David Schweiner

Ing. Zbyněk Zámečník

DiS. Jiří Šmerák

Library of Cross-Sections and Materials

Ing. Ph.D. Jan Rybín

Stanislav Krytinář

Jan Brnušák

Design of Program, Dialog Boxes and Icons

Dipl.-Ing. Georg Dlubal

MgA. Robert Kolouch

Ing. Jan Milěř

Testing and Technical Support

Ing. Ctirad Martinec

Ing. Martin Vasek

Ing. Ph.D. Peter Chromiak

Dipl.-Ing. (FH) René Flori

Dipl.-Ing. (FH) Matthias Entenmann

Dipl.-Ing. Frank Faulstich

M. Sc. Dipl.-Ing. (FH) Frank Lobisch

Dipl.-Ing. (BA) Andreas Niemeier

Dipl.-Ing. (FH) Walter Rustler

M. Sc. Dipl.-Ing. (FH) Frank Sonntag

Dipl.-Ing. (FH) Christian Stautner

Dipl.-Ing. (FH) Robert Vogl

Manuals, Documentation and Translations

Ing. Ph.D. Peter Chromiak

Dipl.-Ing. (FH) Robert Vogl

Mgr. Petra Pokorná

Ing. Petr Míchal

Ing. Ladislav Kábrt

Ing. Dmitry Bystrov

Mgr. Michaela Kryšková

1.3 Using the Manual

All general topics such as installation, user interface, results evaluation and printout report are described in detail in the manual for the main program RSTAB. Hence, we omit them in this manual and will focus on typical features of the add-on module STEEL BS.



During the description of STEEL BS, we use the sequence and structure of the different input and output tables. We feature the described **icons** (buttons) in square brackets, e.g. [Pick]. The buttons are simultaneously displayed on the left margin. The **names** of dialog boxes, tables and particular menus are marked in *italics* in the text so that they can be easily found in the program.

The index at the end of this manual enables you to quickly look up specific terms.

1.4 Starting STEEL BS

It is possible to initialize the add-on module STEEL BS in several ways.

Main Menu

You can call up STEEL BS by the command from the main menu of the RSTAB program:

Add-on Modules → Design - Steel → STEEL BS.

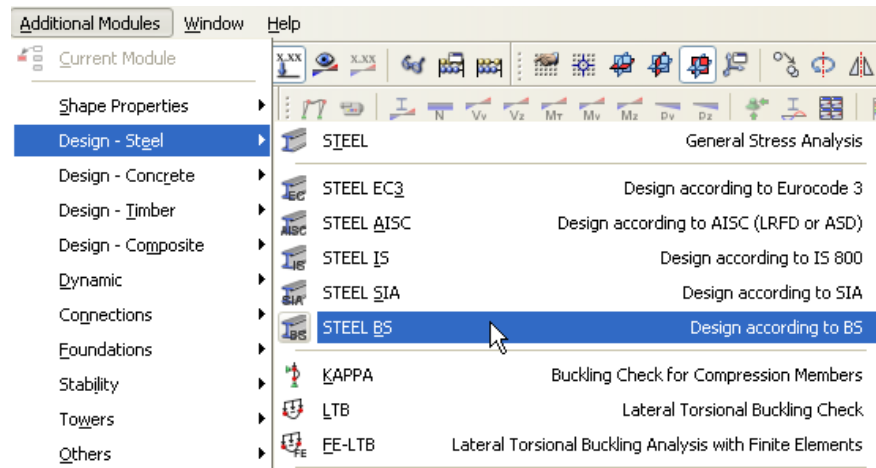

Figure 1.1: Main Menu: *Additional Modules → Design - Steel → STEEL BS*

Navigator

Further, it is possible to start STEEL BS from the *Data* navigator by clicking on the item

Add-on Modules → STEEL BS.

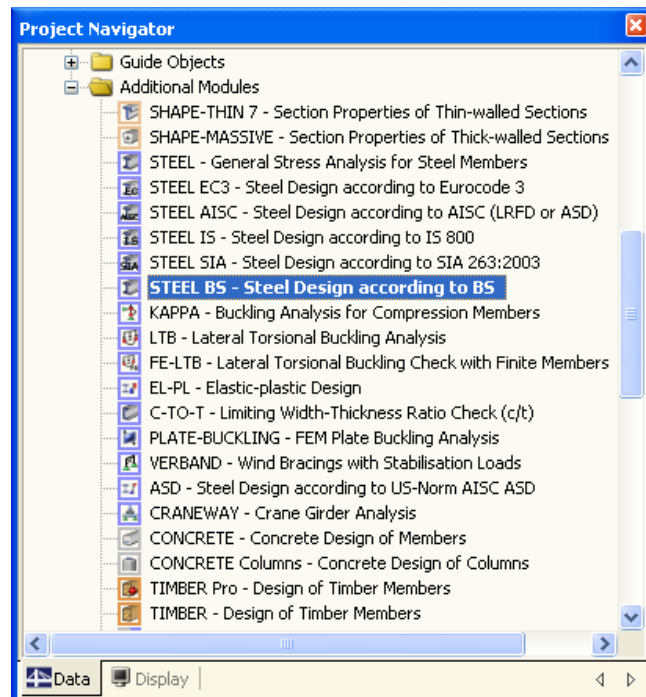

Figure 1.2: Data Navigator: *Additional Modules → STEEL BS*

Panel

If results of STEEL BS are already available in the RSTAB position, you can set the relevant design case of this module in the list of load cases in the menu bar. The design criterion on members is displayed graphically in the work window of RSTAB by using the [Results on/off] button.

The [STEEL BS] button that enables you to start STEEL BS is now available in the panel.

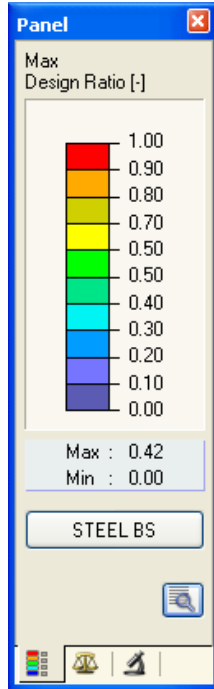
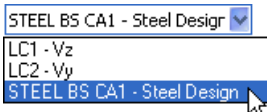

Figure 1.3: [STEEL BS] button in panel

2. Input Data



The data of the design cases is to be entered in different tables of the module. Furthermore, the graphic input using the function [Pick] is available for members and sets of members.

After the initialization of the STEEL BS module, a new window is displayed. In its left part, a navigator is shown that enables you to access all existing tables. The roll-out list of all possibly entered design cases is located above this navigator (see chapter 7.1, page 51).

If STEEL BS is called up for the first time in a position of RSTAB, the following important data is loaded automatically:

- Members and sets of members
- Load cases, load groups and combinations
- Materials
- Cross-sections
- Internal forces (in the background – if calculated)



You can switch among the tables either by clicking on the individual navigator items of STEEL BS or by using the buttons visible on the left. The [F2] and [F3] function keys can also be used to browse the tables in both directions.

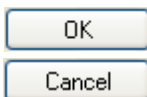

Save entered data by the [OK] button and close the module STEEL BS, while by the [Cancel] button you terminate the module without saving data.

2.1 General Data

In the table 1.1 *General Data*, members, sets of members and actions are selected for the design. You can specify load cases, load groups and combinations for the ultimate limit state and the serviceability limit state design separately in the corresponding tabs.

2.1.1 Ultimate Limit State

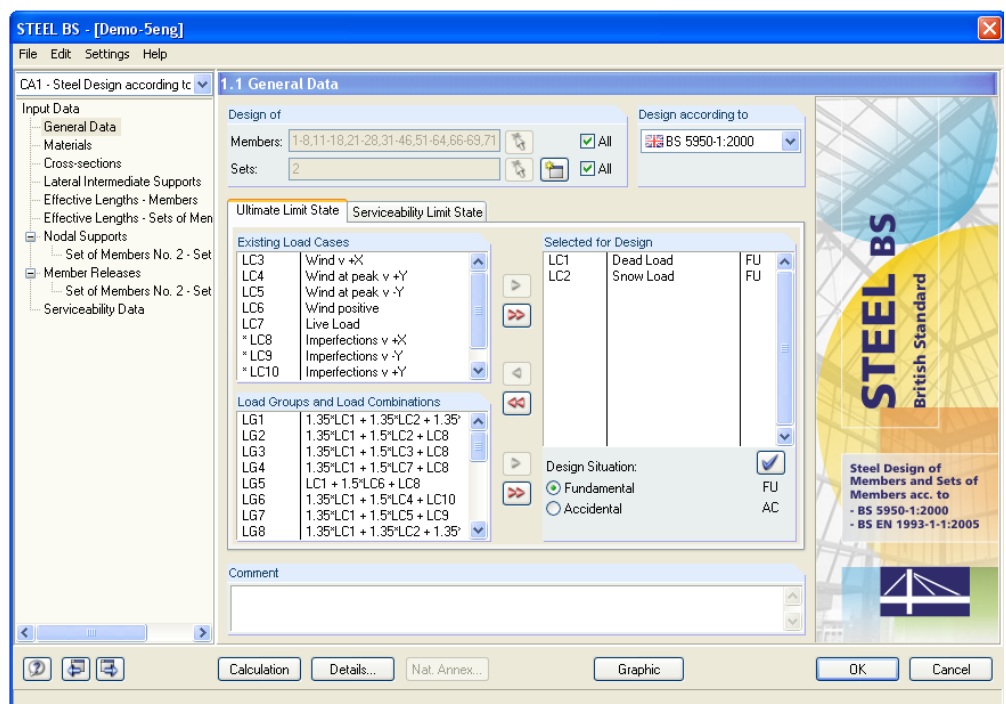

Figure 2.1: Table 1.1 *General Data*, *Ultimate Limit State* tab

Design of



You can select both *Members* and *Sets of Members* for the design. If only specific objects are to be designed, it is necessary to clear the check box *All*. By doing so, both input boxes become accessible and you can enter the numbers of the relevant members or sets of members there. With the [Pick] button, you can also select members or sets of members graphically in the RSTAB work window. To rewrite the list of default member numbers, select it by double-clicking it, and then enter the relevant numbers.



If no sets of members have been defined in RSTAB yet, they can be created in STEEL BS via the [New Set of Members...] button. The familiar RSTAB dialog box to create a new set of members opens in which you enter the relevant data.

Designing sets of members has the advantage that selected members can be analyzed to determine the total maxima of the design ratios. In this case, the results tables 2.3 *Design by Set of Members*, 3.2 *Governing Internal Forces by Set of Members* and 4.2 *Parts List by Set of Members* are displayed additionally.



Design according to

The list box controls whether the analysis is carried out according to the provisions of the BS 5950-1:2000 or the British National Annex of EN 1993-1-1.

Existing Load Cases / Load Groups and Load Combinations



All design-relevant load cases, load groups and load combinations that were created in RSTAB are listed in these two sections. The [▶] button moves the selected load cases, load groups or combinations to the list *Selected for Design* on the right. Specific items can also be selected by double-clicks. The [▶▶] button transfers all items to the list on the right.



If an asterisk (*) is displayed at load cases or combinations, as you can see e.g. in figure 2.1 at load cases 8 to 10, they are excluded from the design. It signifies that no loads were assigned to these load cases or that they contain only imperfections (as in our example).

Furthermore, it is only possible to select load combinations for which the minimum and maximum values can be determined unambiguously. This restriction is necessary because the calculation of the elastic critical moment at lateral buckling requires the unambiguous assignment of moment diagrams. If an invalid load combination is selected, the following warning appears:

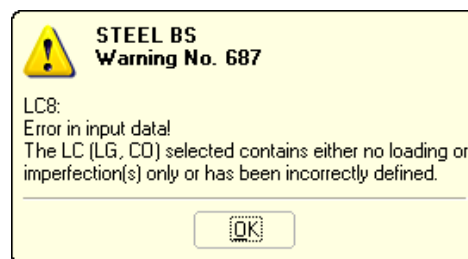

Figure 2.2: Warning when Selecting Invalid LC, LG or CO

A multiple choice of load cases can be done by using the [Ctrl] key, as a routine procedure in Windows. Hence, you can select and transfer several load cases to the list on the right simultaneously.

Selected for Design



The loads selected for the design are listed in the right column. By the [◀] button you can remove the selected load cases, load groups or load combinations from the list. As before, the selection can be executed by double-clicks. The [◀◀] button removes all items from the list.





Generally, the calculation of an enveloping *Or* load combination is faster than the analysis of all contained load cases or groups. On the other hand, you must keep in mind the above-mentioned restriction: to determine the maximum or minimum values unambiguously, the *Or* load combination must only contain load cases, groups or combinations which enter the combination with the criterion *Constant*. Moreover, the design of an enveloping load combination makes it a bit difficult to retrace the influence of the contained actions.

2.1.2 Serviceability Limit State

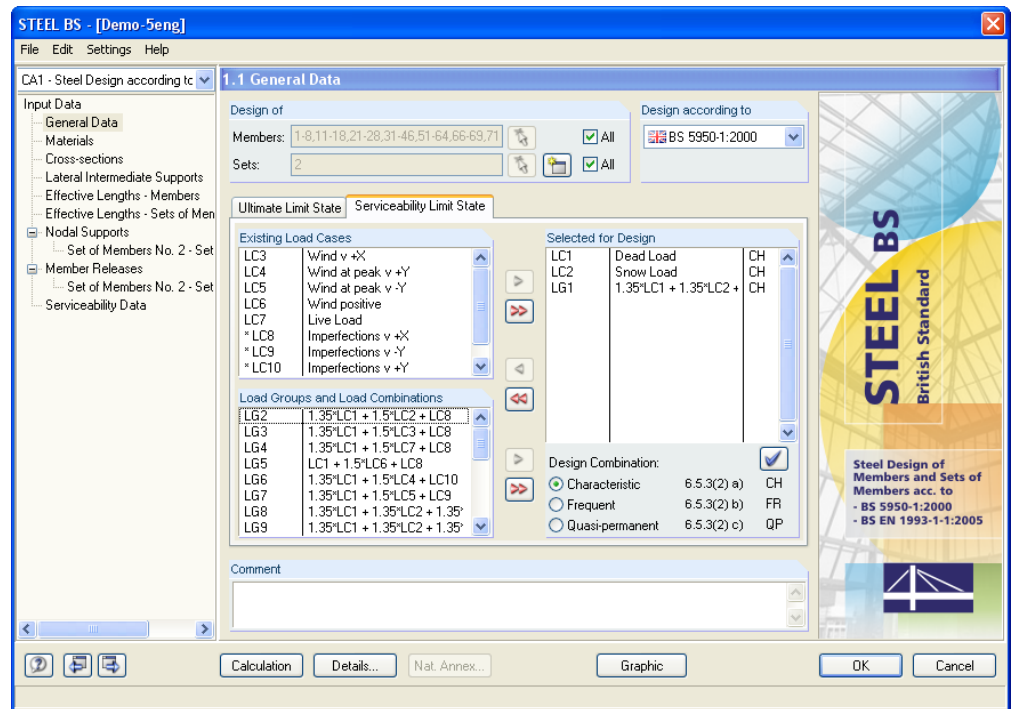

Figure 2.3: Table 1.1 General Data, Serviceability Limit State tab

Existing Load Cases / Load Groups and Load Combinations

All load cases, load groups and load combinations that were created in RSTAB are listed in these two sections.

Selected for Design

Adding load cases and their groups and combinations to the list for the design, resp. removing them from the list is done in the same way like in the previous register tab (see chapter 2.1.1).

Design Combination

In this dialog section, you can set different limit values that are to be applied for the deflections of combined actions. The relevant limit value for the selected design combination can be assigned as follows: Click the action in the list *Selected for Design* to select it. Then click the blue tick to allocate the selected combination.

You can choose among the following criteria as specified in EN 1990:

- Characteristic (CH)
- Frequent (FR)
- Quasi-permanent (QP)



The limit values are settled by the standard. They can be modified in the dialog box that controls the details (see figure 3.1, page 29) resp. the parameters of the National Annex (see figure 2.4, page 11).

Comment

You can enter some additional notes here to describe the current design case.

2.1.3 National Annex (NA)

Nat. Annex...

If the design is to be carried out according to BS EN 1993-1-1, the button [National Annex] is accessible in all input tables. You can use it call up the dialog box *National Annex Settings* that consists of two register tabs.

Base

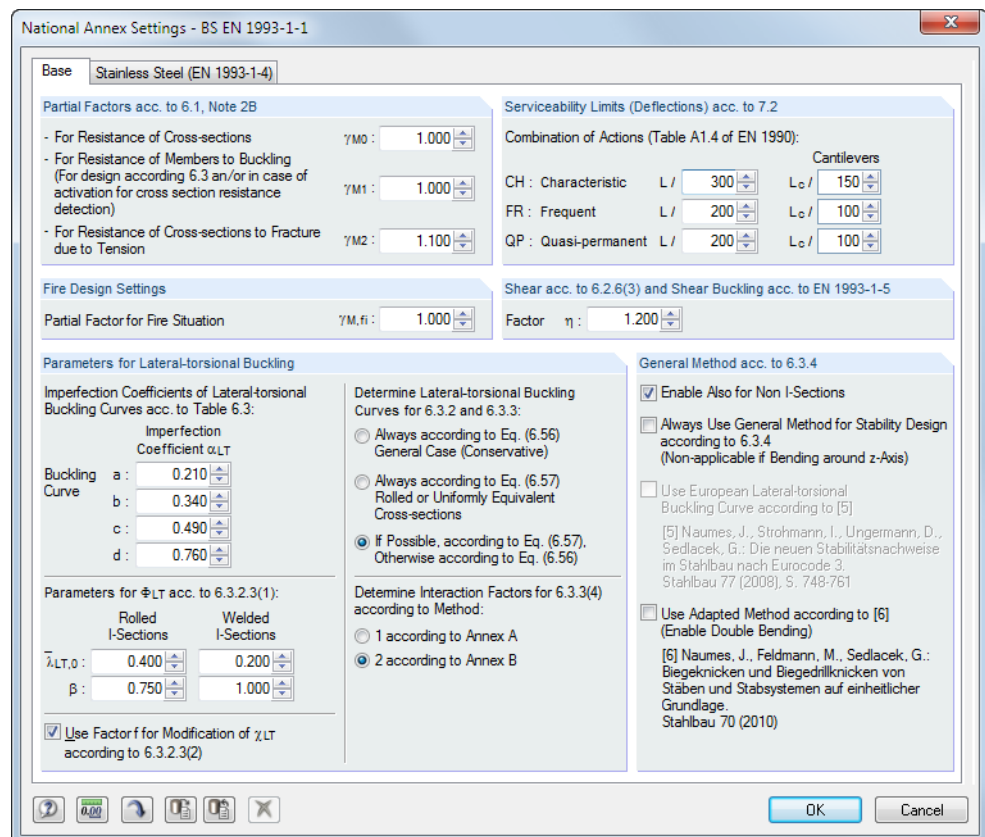

Figure 2.4: Dialog box *National Annex Settings*, tab *Base*

In the dialog sections you can check the *Partial Factors*, the *Serviceability Limits* as well as the *Parameters for Lateral-torsional Buckling* and adjust them, if necessary.



In the dialog section *General Method according to 6.3.4*, it is additionally possible to decide if you want to perform the stability analysis always in accordance with [1], section 6.3.4. (According to the German National Annex, the general method is only allowed to be used for I-shaped cross-sections. By activating the option *Enable Also for Non I-Sections* you can use the method also for other cross-sections.)

In addition, it is possible to perform the stability analysis using the European lateral-torsional buckling curve according to NAUMES [5]. In his dissertation from November 2009, he completed the "General method for lateral and lateral torsional buckling of structural components" design according to EN 1993-1-1:2007 clause 6.3.4 by additional transverse

bending and torsion. This method is available in STEEL BS in order to design unsymmetrical cross-sections as well as tapered members and sets of members with biaxial bending.

According to section 6.3.4 (4), the reduction factor χ_{op} is to be calculated

- a) as minimum value of the values for buckling according to 6.3.1 or χ_{LT} for lateral-torsional buckling according to 6.3.2 by means of the slenderness degree χ_{op} , or
- b) as a value that is interpolated between χ and χ_{LT} (see also equation (6.66) of EN 1993-1-1).

As the method according to NAUMES is based on the standardized European lateral-torsional buckling curve taking into account the modified imperfection factor α^* , the interaction between local buckling and lateral-torsional buckling according to equation (6.66) can be omitted. In the first step, the calculation is carried out separately for the principal and the secondary load-bearing plane.

Calculation	
Principal plane	Secondary plane
$\alpha_{Ed}(x) = \frac{\chi_{LT}(x) \cdot \alpha_{ult,k}(x)}{\gamma_{M1}} \geq 1$	$\beta_z(x) = \frac{M_{z,Ed}(x)}{M_{z,Rd}(x)} \cdot (1 - q_{Mz})$
Design	
simplified	accurate
$\Delta n_R = 0.9$	$\Delta n_R = 1 - \frac{1}{\alpha_{Ed}(x)} \cdot \left[1 - \frac{1}{\alpha_{Ed}(x)} \right] \cdot \chi_{LT}^2(x) \cdot \bar{\lambda}_{LT}^2(x)$
$\frac{1}{\alpha_{Ed}(x)} + \beta_z(x) \leq \Delta n_R$	

Figure 2.5: Calculation run for the method according to NAUMES

In the second step, the design criterion Δn_R is determined. Finally, the design concerning the summation of the design ratios for the principal and the secondary load-bearing plane is performed and compared to the design criterion Δn_R .



Moment diagram M_z	q_{Mz}
	$q_{Mz} = 0.21 \cdot (1 - \psi_z) + 0.36 \cdot (0.33 - \psi_z) \cdot \frac{1}{\alpha_{crit}} \leq \frac{1}{\alpha_{crit}}$
	$q_{Mz} = \frac{1}{\alpha_{crit}} \cdot \left(1 - \frac{\pi^2 EI_z \cdot \max \delta_y }{l^2 \cdot \max M_{z,Ed} } \right)$
	
	$q_{Mz} = 0.18 \cdot \frac{1}{\alpha_{crit}}$
	$q_{Mz} = 0.03 \cdot \frac{1}{\alpha_{crit}}$

Figure 2.6: Determination of the moment factor q_{Mz}

Stainless Steel

STEEL BS also allows for the design of structural components made of stainless steel according to EN 1993-1-4 [4].

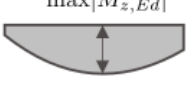
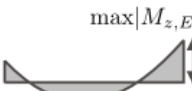
In the second tab of the dialog box *National Annex Settings* you find the relevant *Partial Factors* and *Parameters for Stability Design*.

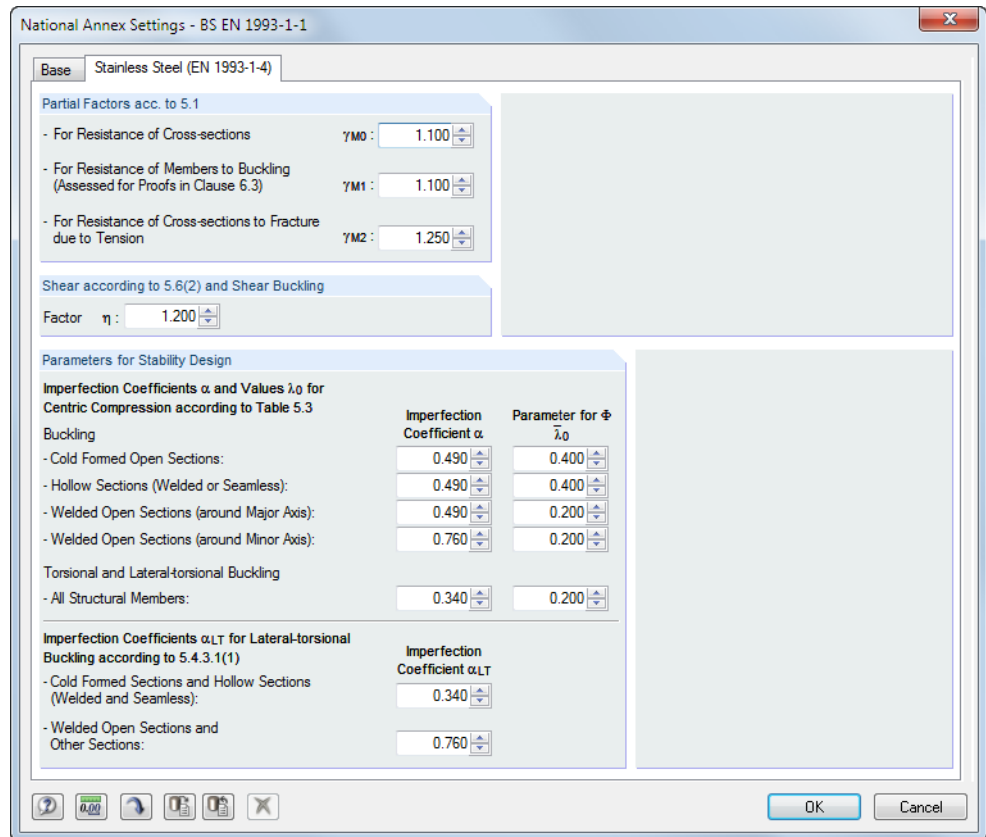

National Annex Settings - BS EN 1993-1-1

Base Stainless Steel (EN 1993-1-4)

Partial Factors acc. to 5.1

- For Resistance of Cross-sections γ_{M0} : 1.100
- For Resistance of Members to Buckling (Assessed for Proofs in Clause 6.3) γ_{M1} : 1.100
- For Resistance of Cross-sections to Fracture due to Tension γ_{M2} : 1.250

Shear according to 5.6(2) and Shear Buckling

Factor η : 1.200

Parameters for Stability Design

Imperfection Coefficients α and Values λ_0 for Centric Compression according to Table 5.3

Buckling	Imperfection Coefficient α	Parameter for Φ λ_0
- Cold Formed Open Sections:	0.490	0.400
- Hollow Sections (Welded or Seamless):	0.490	0.400
- Welded Open Sections (around Major Axis):	0.490	0.200
- Welded Open Sections (around Minor Axis):	0.760	0.200
Torsional and Lateral-torsional Buckling		
- All Structural Members:	0.340	0.200

Imperfection Coefficients α_{LT} for Lateral-torsional Buckling according to 5.4.3.1(1)

	Imperfection Coefficient α_{LT}
- Cold Formed Sections and Hollow Sections (Welded and Seamless):	0.340
- Welded Open Sections and Other Sections:	0.760

OK Cancel

Figure 2.7: Dialog box *National Annex Settings*, tab *Stainless Steel (EN 1993-1-4)*

2.2 Materials

This table is divided into two parts. The materials for the design are listed in the upper part. In the lower part, the *Material Properties* of the current material are displayed, i.e. the material whose line is selected in the upper table.

Materials that won't be used in the design appear gray in color. Materials that are not allowed are highlighted in red. Modified materials are displayed in blue.

The material properties required to calculate the internal forces in RSTAB are described in detail in the RSTAB manual, chapter 5.2. The design-relevant material characteristics are stored in the global material library. Those are automatically set as default.

The units and decimal places of the material properties and stresses can be edited from the main menu **Options** → **Units and Decimal Places** (see chapter 7.4, page 56).

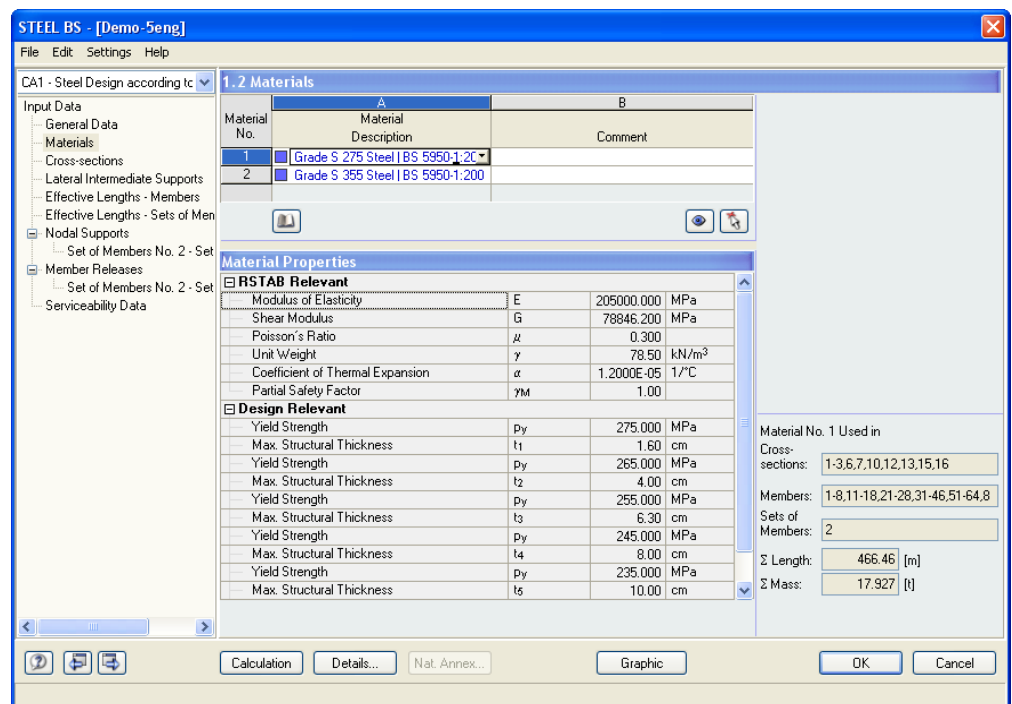

Figure 2.8: Table 1.2 Materials

Material Description

The materials that have been defined in RSTAB are set by default. You can also enter materials manually here. If the *Material Description* corresponds to an entry in the material library, STEEL BS automatically imports the relevant material properties.

To select a material from the list, place the cursor in column A and click on the [▼] button or press the [F7] function key. A list is opened that you can see on the left. As soon as you have chosen the appropriate material, the material characteristics are updated in the table below.

According to the design concept of British Standard, the list of materials includes only materials from the category **Steel**. How to import materials from the library is described below.

Basically, it is not possible to edit the material properties in STEEL BS.

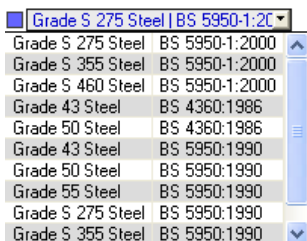

Material Library

A considerable amount of materials is stored in the library. Open the library via menu

Edit → Material Library

or by clicking on the button visible on the left.

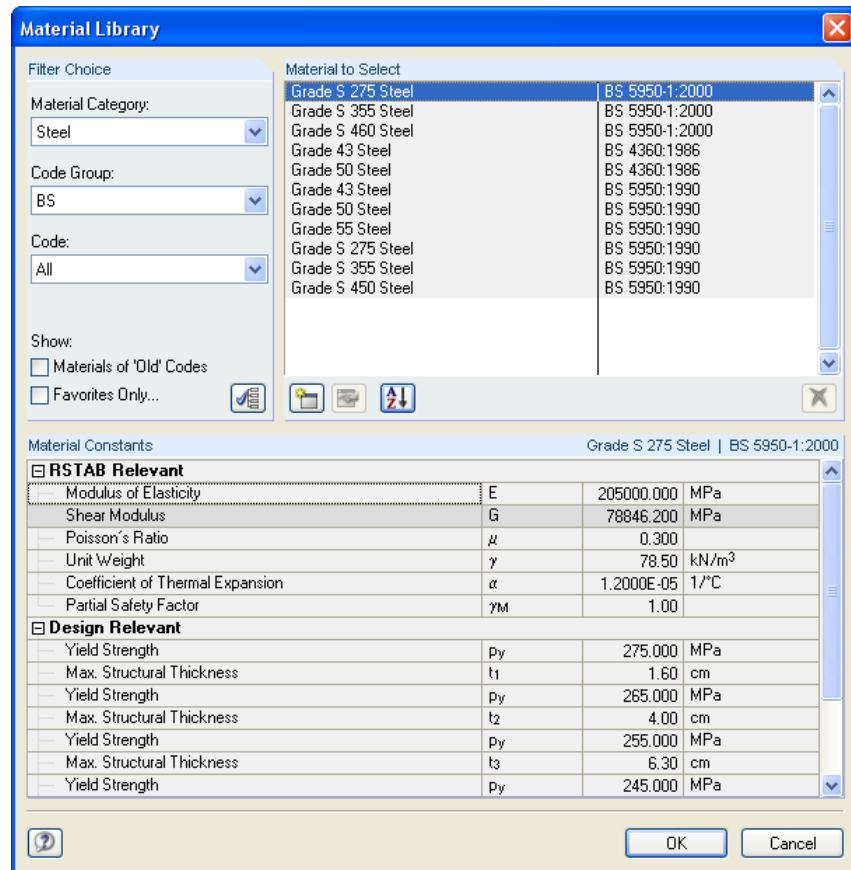
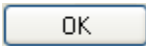

Figure 2.9: Material Library Dialog Box

In the section *Filter Choice*, the material category **Steel** is set by default. In the list *Material to Select* which is located on the right, you can select a particular material, and in the lower part of the dialog box you can check its characteristic values.



After clicking on [OK] or pressing the [↵] key, the material is taken over to the table 1.2 *Materials of STEEL BS*.

Chapter 5.2 of the RSTAB manual explains in detail how materials can be filtered, added to the library or newly classified.

You can also select materials of the categories *Cast Iron* and *Stainless Steel* from the library. However, please reflect whether those materials are covered by the design rules of British Standard.

2.3 Cross-Sections

This table controls the cross-sections that are to be designed. The parameters of the optimization can be defined here as well.

Coordinate System



The sectional coordinate system *yz* of STEEL BS corresponds to the one of RSTAB (see image in figure 2.10). The *y*-axis is the major principal axis of the cross-section, the *z*-axis the minor axis. This coordinate system is used for both the input data and the results.

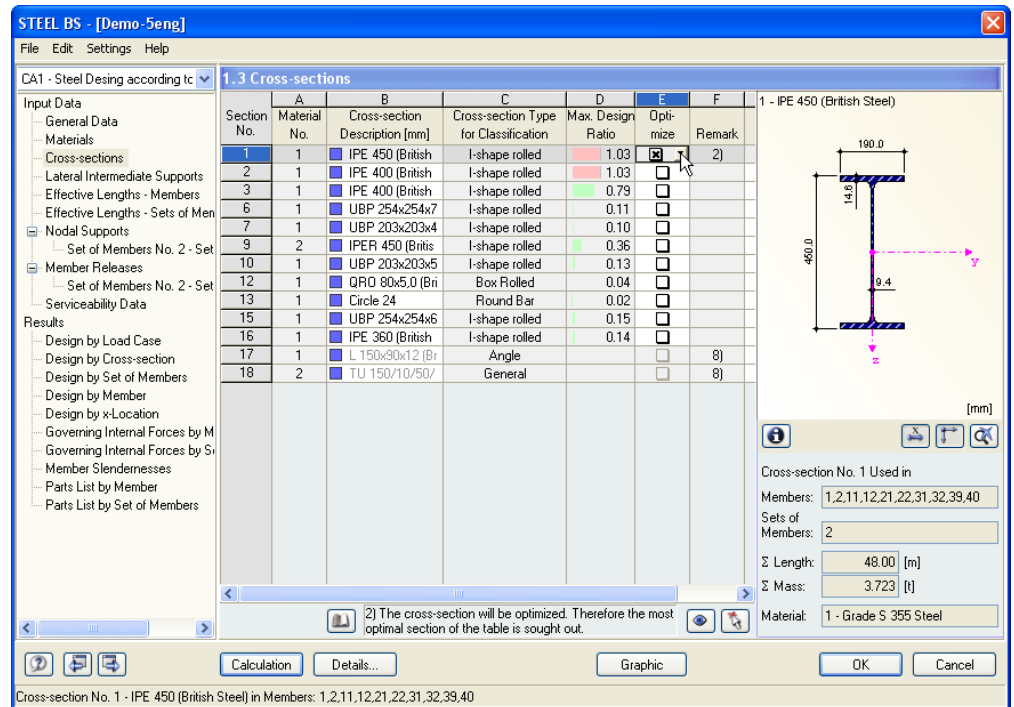

Figure 2.10: Table 1.3 Cross-Sections

Cross-Section Description

When you open this table, the sections that were defined in RSTAB are set by default, including the assigned material numbers.

The cross-sections can be changed any time for the design. The description of a modified cross-section is highlighted in blue color.



In order to edit a cross-section, enter the new description in the corresponding line or select the new section from the library. Open the database by clicking on the [Library] button. Alternatively, place the cursor in the corresponding line and click on the [...] button or press the [F7] key. The library opens which is already familiar from RSTAB (see figure 2.11).

Chapter 5.3 of the RSTAB manual describes in detail how cross-sections can be selected from the library.

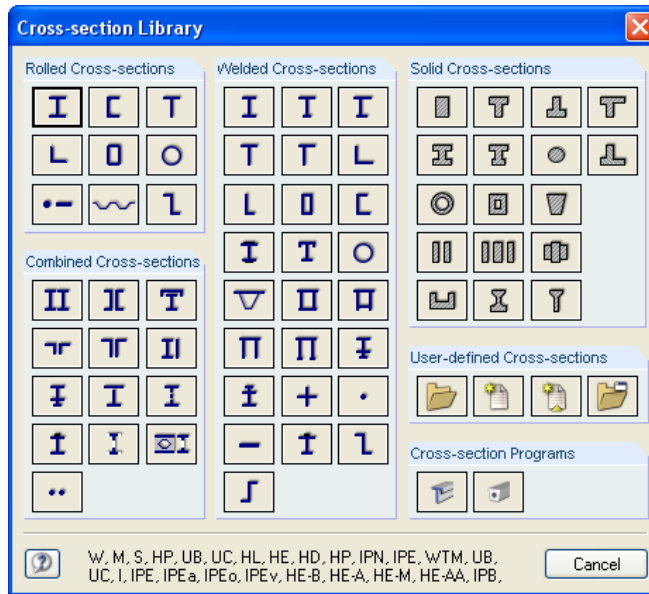
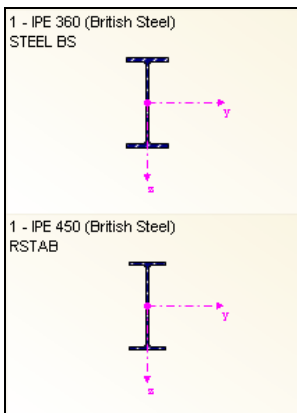

Figure 2.11: Cross-Section Library with Admissible Sections

If the cross-sections are different in STEEL BS and RSTAB, both cross-sections are shown in the graphic window next to the table. The internal forces from RSTAB are then used for the stress design of the cross-section that is set in STEEL BS.

Tapered Member

In case of a tapered member with different cross-sections at the member start and member end, both cross-section numbers are stated in two lines, following the definition in RSTAB.

You can design tapered members in STEEL BS if the following condition is fulfilled: an equal number of stress points is required at both member ends: For example, the normal stresses are calculated from the moments of inertia and from the centroidal distances of the stress points. If the start and end cross-sections of the tapered member have different numbers of stress points, STEEL BS cannot interpolate the intermediate values. An error message appears before the calculation:

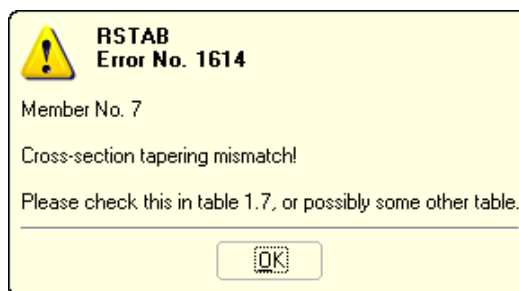

Figure 2.12: Warning in Case of Incompatible Cross-Sections



To check on the stress points of the cross-section, you can display them including their numbers: Select the cross-section in the table 1.3 and click on the [Info] button. The dialog box Info about cross-section appears (see figure 2.13).

Info about Cross-Section

There are different display options for stress points and c/t cross-section parts in this dialog box.

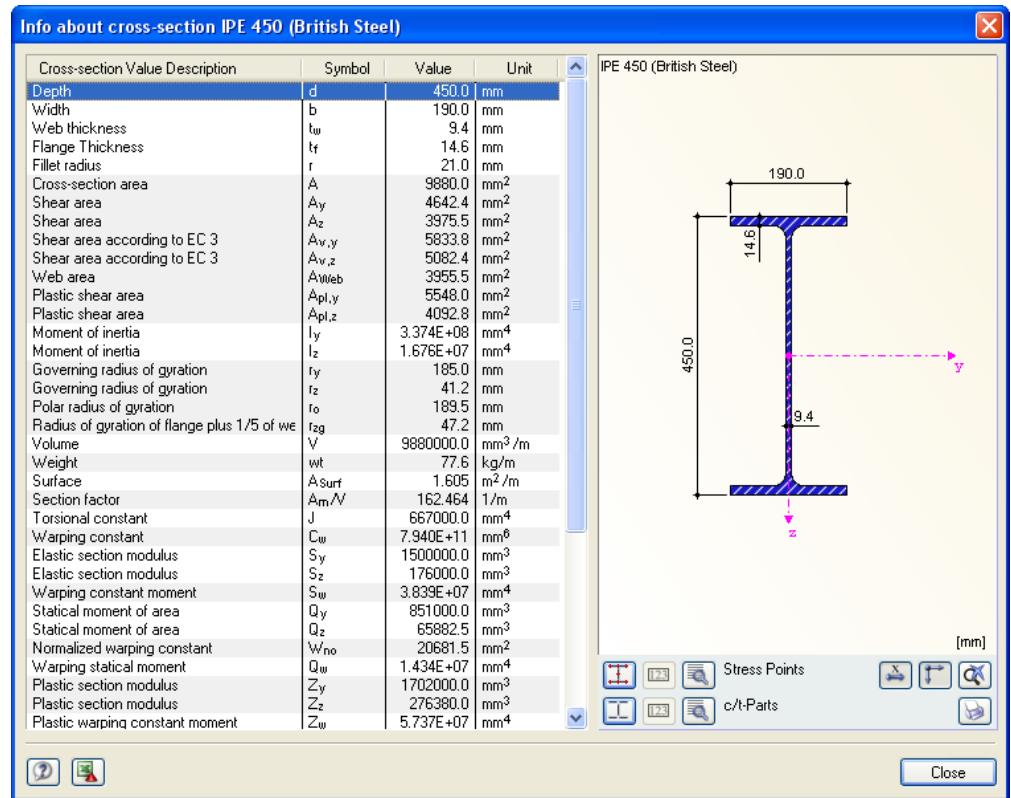

Figure 2.13: Info about Cross-Section Dialog Box

The currently selected cross-section is displayed in the right part of the dialog box. The various buttons below have the following functions:







Button	Function
	The stress points are switched on and off.
	The cross-section parts (c/t) are switched on and off.
	The numbering of stress points or cross-section parts (c/t) is switched on and off.
	The details of stress points or cross-section parts (c/t) are displayed.
	The dimensioning of the cross-section is switched on and off.
	The principal axes of the cross-section are switched on and off.

Table 2.1: Buttons for Cross-Section Graphics

Cross-Section Type for Classification

In this column, the various cross-section types are listed which are applied for the design (e.g. I-shape rolled or welded, box, round bar etc.)

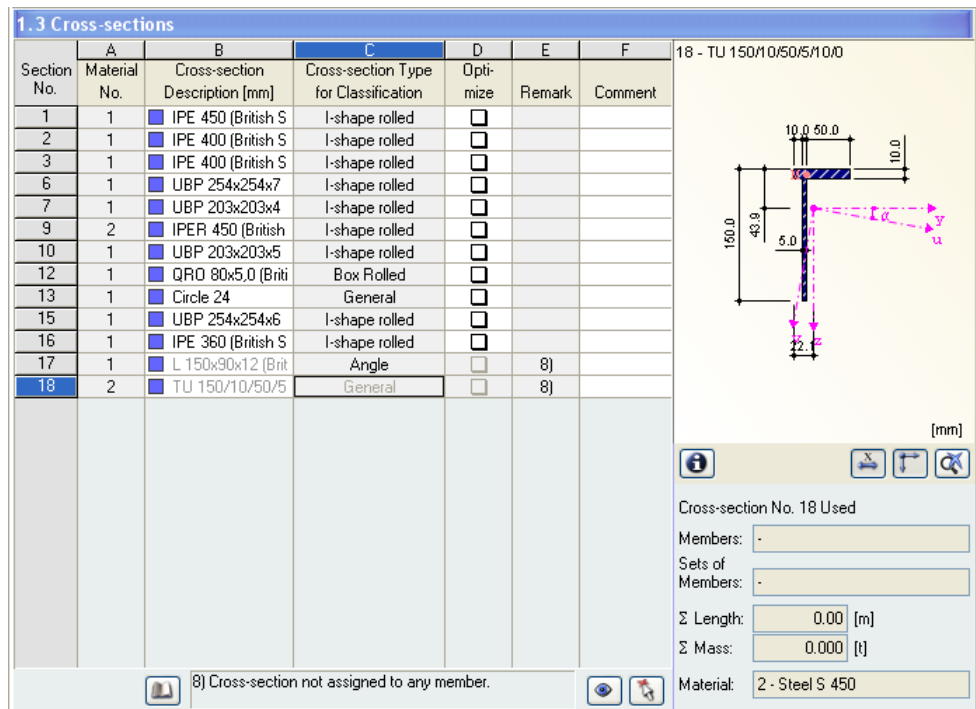

Figure 2.14: Cross-section Types for Classification

Max. Design Ratio

This column is only displayed after STEEL BS has designed the cross-sections. It is useful to decide whether to carry out an optimization. The values and the colored relation scales in this column indicate which cross-sections have a low design ratio and therefore are oversized, resp. which are overstrained and therefore are too weak.

Optimize

Every cross-section can be optimized. During the optimization process, the cross-section within the same group of cross-sections is determined on the basis of the internal forces from RSTAB which fulfills best the maximum design ratio. Figure 2.10 shows how the optimization of a particular cross-section is set by ticking the corresponding box in column D.

The maximum allowable design ratio for the optimization is controlled in the *Details* dialog box, see chapter 3.1. Further information on the optimization of cross-sections can be found in chapter 7.2 on page 53.

Remark

In this column, the references to footnotes (below the list of cross-sections) are shown.



If the message *Non-permissible Cross-Section No. XX* appears before the design, then this is due to a cross-section which is not contained in the cross-section library. It may be a user-defined cross-section or a cross-section that was not calculated in the module SHAPE-THIN. Via the [...] button in column B *Cross-section Description*, you can set a cross-section that is suitable for the design (see figure 2.11 with following remarks).

2.4 Lateral Intermediate Supports

In this table, lateral intermediate supports on members can be defined. The program always assumes these supports as perpendicular to the minor axis z (see figure 2.10) of the cross-section. Hence, it is possible to change the effective lengths of the member that are important for the design of column buckling and lateral torsional buckling.



Please note that lateral intermediate supports are considered as forked supports for the design.

The screenshot shows the '1.4 Lateral Intermediate Supports' table with the following data:

Member No.	Lateral Supports	Length L [m]	Number	x1	x2	x3	x4	x5	x6	x7	x8	x9
1	<input type="checkbox"/>	6.000										
2	<input checked="" type="checkbox"/>	6.000	1	0.500								
3	<input type="checkbox"/>	3.011										
4	<input checked="" type="checkbox"/>	3.262	2	0.333	0.667							
5	<input type="checkbox"/>	6.274										
6	<input checked="" type="checkbox"/>	6.274	3	0.250	0.500	0.750						
7	<input type="checkbox"/>	3.262										

Below the table, the 'Settings for Member No. 6' are displayed:

- Cross-section: 2 - IPE 400 (British Steel)
- Lateral Supports Existing:
- Member Length: L = 6.274 m
- Number of Lateral Intermediate Supports: n = 3
- Position of Lateral Support No. 1: x1 = 0.250
- Position of Lateral Support No. 2: x2 = 0.500
- Position of Lateral Support No. 3: x3 = 0.750

A 3D diagram on the right shows a beam with three intermediate supports. A checkbox 'Relatively (0 ... 1)' is checked. At the bottom, there are buttons for 'Calculation', 'Details...', 'Nat. Annex...', 'Graphic', 'OK', and 'Cancel'.

Figure 2.15: Table 1.4 Lateral Intermediate Supports

In the upper part of this table, up to nine lateral intermediate supports can be created per member. The lower part of the table displays the summary of the entered data for every single member.

Relatively (0 ... 1)



Lateral intermediate supports can be defined either by directly entering the distances from the member start or by specifying the support locations *Relatively*. For the latter, it is necessary to tick the associated check box below the list. The locations of the supports are then calculated from the member lengths and the defined intervals.

You have to be very careful if the model contains cantilever beams. Intermediate supports divide the member into several parts for the design. Therefore, intermediate supports are to be avoided for cantilever beams because they would imply statically underdetermined pieces with fork-type supports on only one side each.

2.5 Effective Lengths - Members

The table 1.5 consists of two parts so that a good overview of the data is provided. In the upper table, the effective length factors K_y and K_z , the effective lengths KL_y and KL_z , the equivalent uniform moment factor m_{LT} , lateral-torsional factor K_{LT} and the effective length for lateral-torsional buckling KL_{LT} are summarized for every member. In the lower part of this table, detailed information on the member that is selected in the upper table is displayed. The lower table contains all information about the relevant lengths of this member.

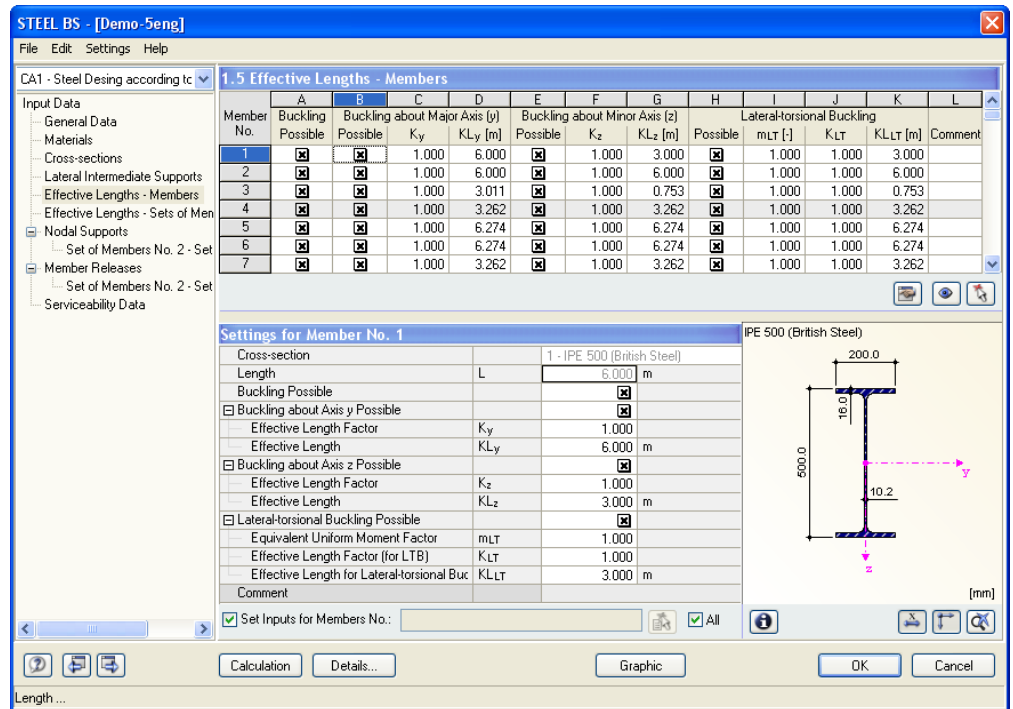

The screenshot shows the STEEL BS software interface. The main window displays a table titled '1.5 Effective Lengths - Members' with columns for Member No., Buckling Possible, Buckling about Major Axis (y), Buckling about Minor Axis (z), and Lateral-torsional Buckling. The table lists 7 members with their respective parameters. Below the table, the 'Settings for Member No. 1' dialog box is open, showing detailed parameters for member 1, including Cross-section (1 - IPE 500 [British Steel]), Length (6.000 m), and various buckling coefficients and lengths. A diagram of the IPE 500 cross-section is also visible on the right side of the dialog box.

Member No.	Buckling Possible	Buckling about Major Axis (y) Possible	K_y	KL_y [m]	Buckling about Minor Axis (z) Possible	K_z	KL_z [m]	Lateral-torsional Buckling Possible	m_{LT} [-]	K_{LT}	KL_{LT} [m]	Comment
1	<input checked="" type="checkbox"/>	<input checked="" type="checkbox"/>	1.000	6.000	<input checked="" type="checkbox"/>	1.000	3.000	<input checked="" type="checkbox"/>	1.000	1.000	3.000	
2	<input checked="" type="checkbox"/>	<input checked="" type="checkbox"/>	1.000	6.000	<input checked="" type="checkbox"/>	1.000	6.000	<input checked="" type="checkbox"/>	1.000	1.000	6.000	
3	<input checked="" type="checkbox"/>	<input checked="" type="checkbox"/>	1.000	3.011	<input checked="" type="checkbox"/>	1.000	0.753	<input checked="" type="checkbox"/>	1.000	1.000	0.753	
4	<input checked="" type="checkbox"/>	<input checked="" type="checkbox"/>	1.000	3.262	<input checked="" type="checkbox"/>	1.000	3.262	<input checked="" type="checkbox"/>	1.000	1.000	3.262	
5	<input checked="" type="checkbox"/>	<input checked="" type="checkbox"/>	1.000	6.274	<input checked="" type="checkbox"/>	1.000	6.274	<input checked="" type="checkbox"/>	1.000	1.000	6.274	
6	<input checked="" type="checkbox"/>	<input checked="" type="checkbox"/>	1.000	6.274	<input checked="" type="checkbox"/>	1.000	6.274	<input checked="" type="checkbox"/>	1.000	1.000	6.274	
7	<input checked="" type="checkbox"/>	<input checked="" type="checkbox"/>	1.000	3.262	<input checked="" type="checkbox"/>	1.000	3.262	<input checked="" type="checkbox"/>	1.000	1.000	3.262	

Figure 2.16: Table 1.5 Effective Lengths - Members

The effective lengths for the column buckling about the minor principal axis are automatically loaded from the previous table 1.4. If a member is divided into different lengths by lateral intermediate supports, then no values are displayed in the corresponding columns D and G of table 1.5.

It is possible to change the buckling length coefficients both in the summary table in the upper part and in the detailed settings in the lower part. The data of the corresponding part of this table is then updated automatically. The buckling length of a member can also be defined graphically by using the function [Pick].

The tree structure in the lower part of the *Settings for Member* table contains the following parameters:

- *Cross-section*
- *Length* (actual length of the member)
- *Buckling Possible* for member (cf column A)
- *Buckling/Lateral-torsional Buckling Possible* (cf columns B, E and H)
- *Buckling about Mayor Axis y Possible* (buckling lengths, cf columns C and D)
- *Buckling about Minor Axis z Possible* (buckling lengths, cf columns F and G)
- *Lateral-torsional Buckling Possible* (lateral-torsional length, cf columns H to K)

It is also possible to modify the *Buckling Length Coefficients* in the relevant directions and decide whether the buckling design is to be executed. If a buckling length coefficient is changed, the respective effective member length is modified automatically.



The effective length factors of the members can also be defined in a special dialog box which is called by the button [Select Effective Length Factor] below the upper table.

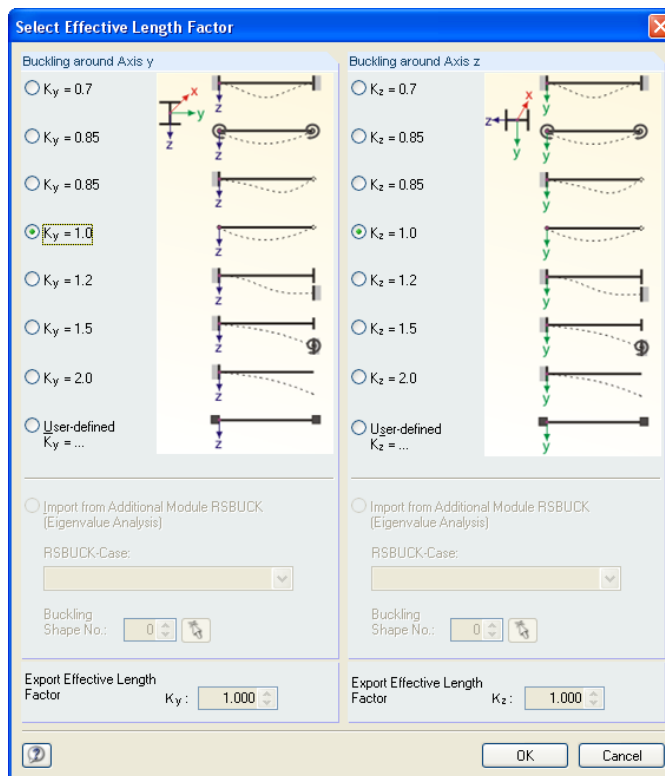

Figure 2.17: Dialog box: *Select Effective Length Factor*

The predefined values of the effective length factor **K** corresponds to the following definitions:

- $K = 0.7$ effectively held in position at both ends + effectively restrained in direction at both ends
- $K = 0.85$ effectively held in position at both ends + partially restrained in direction at both ends
- $K = 0.85$ effectively held in position at both ends + restrained in direction at one end
- $K = 1.0$ effectively held in position at both ends + not restrained in direction at either end
- $K = 1.2$ effectively held in position and restrained in direction at one end + not held in position and effectively restrained in direction at other end
- $K = 1.5$ effectively held in position and restrained in direction at one end + not held in position and partially restrained in direction at other end
- $K = 2.0$ effectively held in position and restrained in direction at one end + not held in position and not restrained in direction at other end

The effective lengths for buckling can also be imported from the add-on module RSBUCK.

Buckling Possible

For the stability design of the buckling and lateral-torsional buckling, it is necessary for the member to transfer compression forces. Members that cannot transfer compression forces due to their definition (e.g. tension members, elastic foundations, rigid couplings) are a priori excluded from the stability design in STEEL BS. In such a case, a corresponding comment is displayed in the column *Comment* for this member.

The column *Buckling Possible* makes it possible to classify specific members as compression members or, alternatively, to exclude them from the design. Hence, the check boxes in column A and also in table *Settings for Member No.* control whether the input options for the buckling length parameters are accessible for a member.

Buckling about Axis y resp. Axis z

The columns *Buckling Possible* control members are prone to buckling about their axes y and/or axes z. The axis y represents the "major" principal member axis, the axis z the "minor" principal member axis. The buckling length factors K_y and K_z can be freely chosen for the buckling about the major and minor axes.

The orientation of the member axes can be checked in the cross-section graphics of table 1.3 *Cross-Sections* (see figure 2.10). In the RSTAB work window which is accessible any time via the [Graphic] button, you can display the local member axes from the *Display* navigator.

Graphic

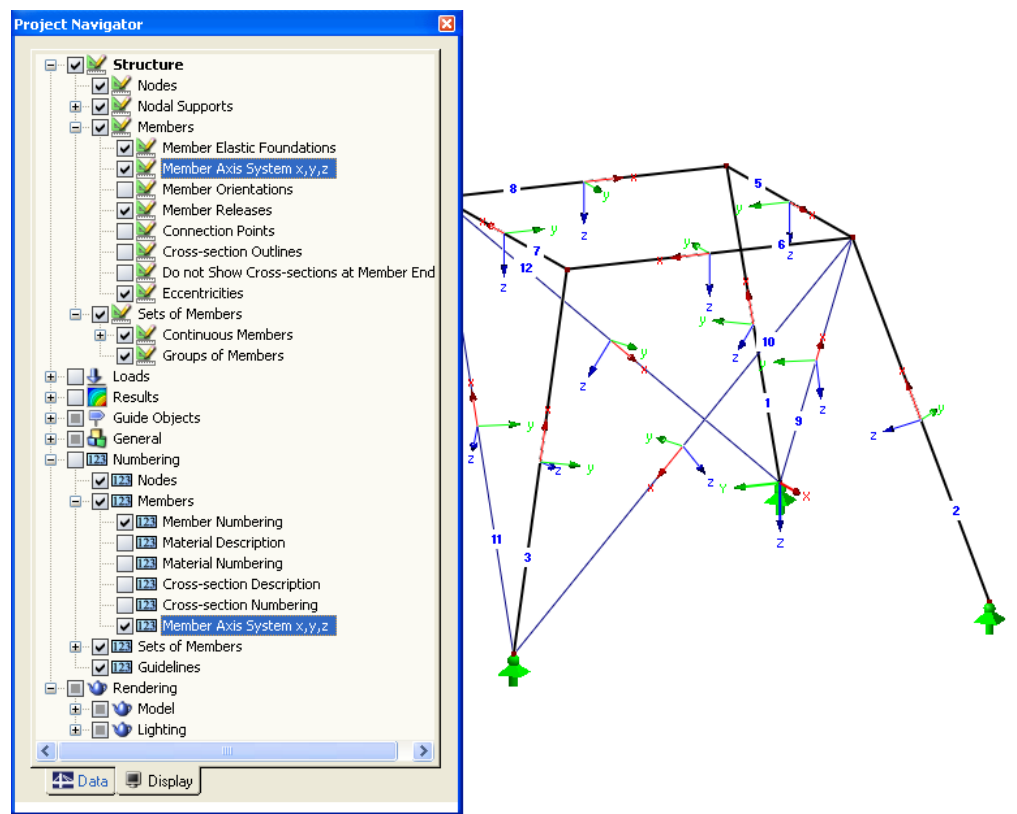

Figure 2.18: Displaying the Local Member Axes in the *Display* Navigator of RSTAB

If buckling is possible about one or both member axes, the precise values can be entered in columns C and D resp. F and G or in table *Settings for Member No.* below.

If you define the buckling length coefficient K , the buckling length KL is determined by multiplying the member length L with this buckling length coefficient.

Via the [...] button at the end of the KL input fields, you can select two nodes in the RSTAB work window graphically. Their distance then defines the buckling length.



Lateral-Torsional Buckling

Column H controls whether a lateral torsional buckling design is to be carried out.

In column I, three options are available for defining the equivalent uniform moment factor m_{LT} . The default value is 1.0. The factor can also be determined by the program according to table 18 [1] or entered manually.

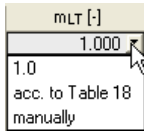

Column J enables you to modify the lateral-torsional buckling coefficient K_{LT} which has an influence on the calculation of the lateral-torsional buckling length. The value of K_{LT} is pre-set to 1.0.

If the lateral-torsional buckling coefficient is changed, the respective lateral-torsional buckling length KL_{LT} is modified automatically. The values in column K depend on the settings in table 1.4 *Lateral Intermediate Supports*. It is also possible to enter values of KL_{LT} manually.

Comment

In the last column the user can write down his own remarks at every member, e.g. to explain more closely the specific lengths of a member.



The check box *Set Inputs for Members No.* is located beneath the tree-structure lower table. If you tick this box, the data entered consequently will become valid for specific resp. *All* members. You can select the members graphically by using the function [Pick] or enter their numbers manually. This option is useful when you want to assign the same boundary conditions to several members. Please notice that this function must be activated prior to data entering. If you define the data and choose this option later, the data is not re-assigned.

2.6 Effective Lengths - Sets of Members

The input table 1.6 controls the effective lengths for sets of members. It is only available if one or more sets of members have been selected in table 1.1 *General Data*.

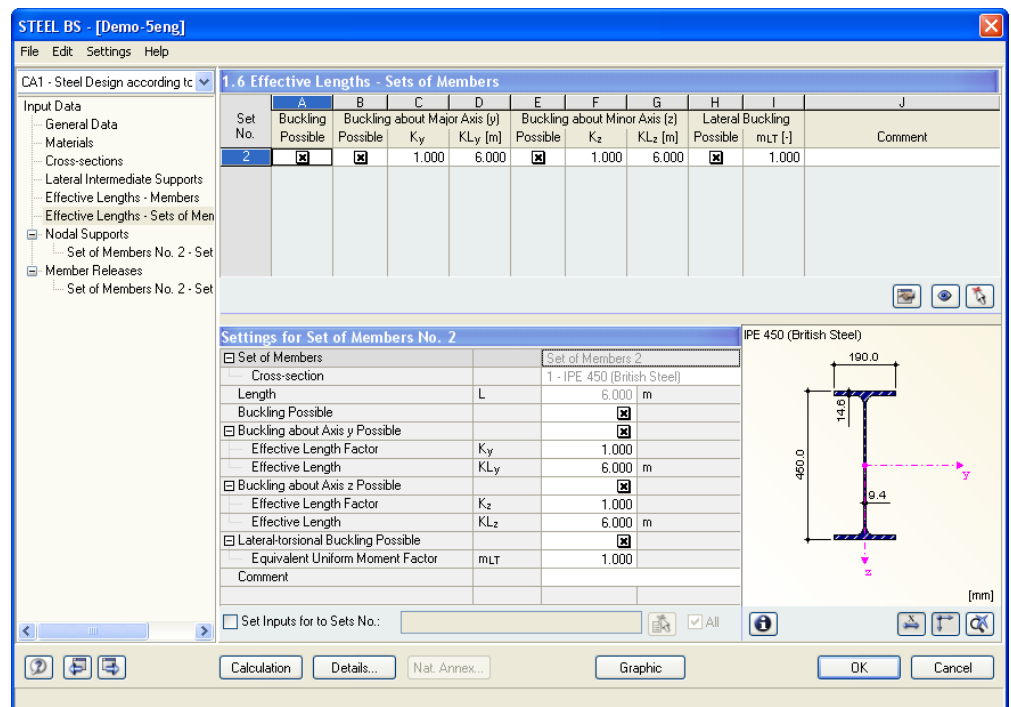

Figure 2.19: Table 1.6 *Effective Lengths - Set of Members*

This table is very similar to the previous table 1.5. With regard to the effective lengths for buckling about the major and minor axes of the cross-sections, it is identical to table 1.5.

There are differences, however, as far as the parameters for torsional and lateral-torsional buckling are concerned. These are defined by means of specific boundary conditions in table 1.8 (see chapter 2.8).

2.7 Nodal Supports



The stability design of sets of members is based on the loads and the boundary conditions of the selected sets of members. The value of the multiplier α_{cr} has to be determined for the entire set of members in order to obtain the critical stress p_E which is necessary for the design. The calculation of α_{cr} , the bifurcation factor, also depends on the settings in the *Details* dialog box (see chapter 3.1, page 29).

To determine α_{cr} , a planar member structure with four degrees of freedom per node is created. The specific support conditions are defined in table 1.7. This table is only available if you have selected one or more sets of member in table 1.1 *General Data*.

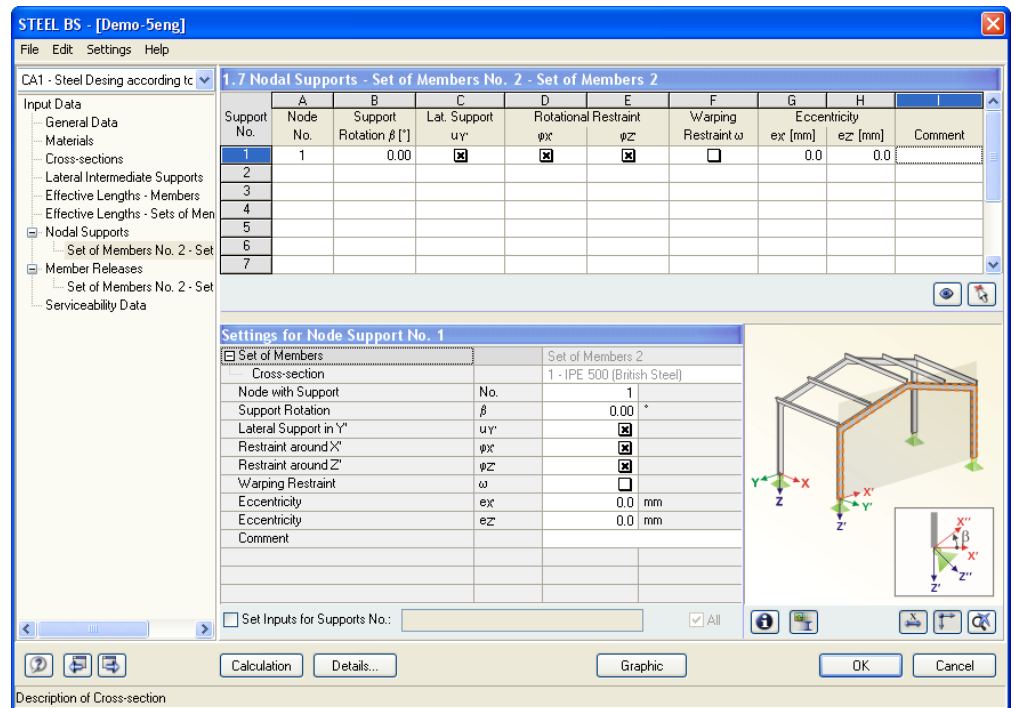

Figure 2.20: Table 1.7 Nodal Supports



To define the nodal supports, the orientation of the axes within a set of members is important. The program internally checks the location of the relevant nodes and then determines the axis systems of the nodal supports that are defined in table 1.7 (see figure 2.21 to figure 2.24).

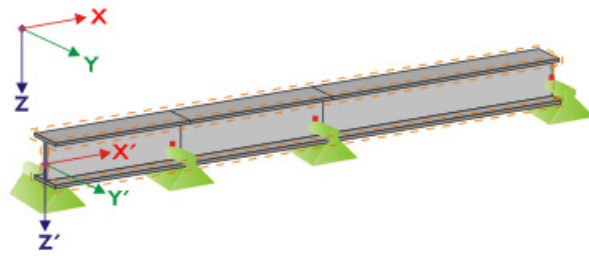

Figure 2.21: Auxiliary coordinate system for nodal supports – straight set of members

If all members within the set of members lie on a straight line, the local coordinate system of the first member within this set is applied for the entire set of members.

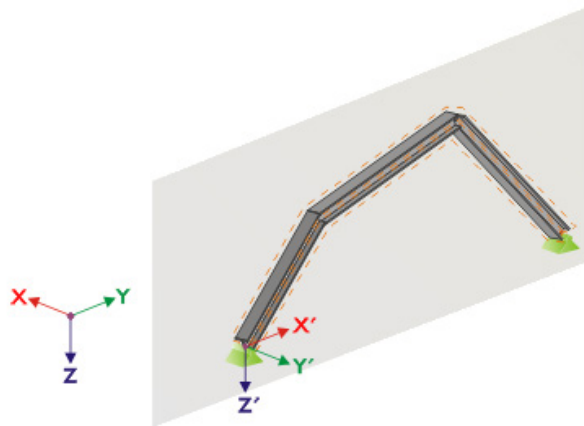

Figure 2.22: Auxiliary coordinate system for nodal supports – set of members in vertical plane

Even if the members within a set do not lie on a straight line, they still must lie in a plane. We can see a vertical plane in figure 2.22. In this case, the axis X' is horizontal and in the plane direction. The axis Y' is also horizontal, but perpendicular to the axis X' . The axis Z' points vertically downwards.

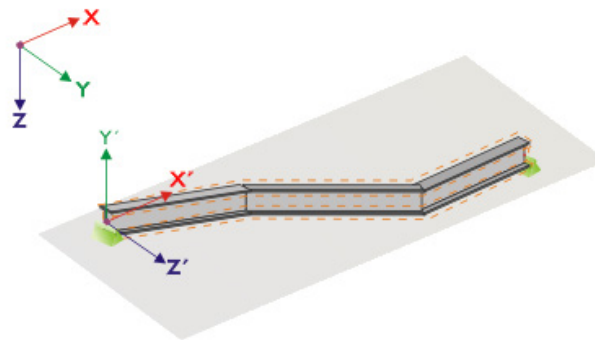

Figure 2.23: Auxiliary coordinate system for nodal supports – set of members in horizontal plane

If the members are located in a horizontal plane, the axis X' is parallel with the axis X of the global coordinate system. The axis Y' then points in the opposite direction of the global axis Z . The axis Z' is parallel with the axis Y of the global coordinate system.

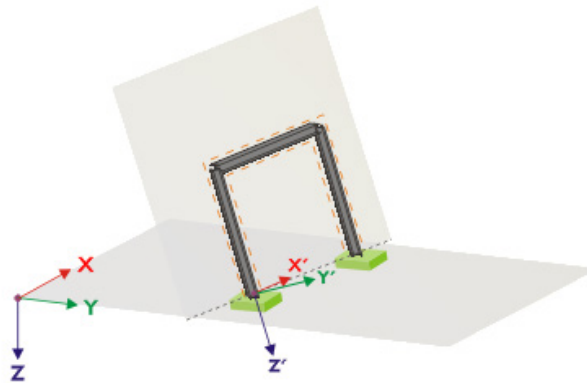

Figure 2.24: Auxiliary coordinate system for nodal supports – set of members in inclined plane

Figure 2.24 shows the most general case. The members within a set of members do not lie on a straight line but are located in one oblique plane. The orientation of the axis X' is then determined by the intersection between the oblique and the horizontal plane. The axis Y' is perpendicular to the axis X' and is also perpendicular to the oblique plane. The axis Z' is perpendicular to the axes X' and Y' .

2.8 Member Releases

This table is only available if one or more sets of members have been selected in table 1.1 *General Data*. If any member in a given set is not able to transfer internal forces corresponding to the degrees of freedom restricted in table 1.7, then nodal releases can be inserted to a set of members in table 1.8. There is also the possibility to exactly define on which side the release is to act or to place a release at both sides.

The screenshot shows the '1.8 Member Releases' table with the following data:

Release No.	Member No.	Member Side	Shear Release V_y	Moment Release M_T	Moment Release M_z	Warp Release M_ω	Comment
1	3	Start	<input checked="" type="checkbox"/>	<input checked="" type="checkbox"/>	<input checked="" type="checkbox"/>	<input type="checkbox"/>	
2							
3							
4							
5							
6							
7							

Below the table, the 'Settings for Member No. 3' are shown:

Set of Members	Set of Members 2
Cross-section	1 - IPE 500 (British Steel)
Member with Release at the End	No. 3
Member Side	Side Start
Shear Release in y-Direction	<input checked="" type="checkbox"/>
Torsional Release	<input checked="" type="checkbox"/>
Moment Release around z-Axis	<input checked="" type="checkbox"/>
Warping Release	<input type="checkbox"/>
Comment	

On the right, a 3D diagram of a beam cross-section shows the coordinate system with axes x , y , and z , and internal forces M_T , M_ω , and M_z .

Figure 2.25: Table 1.8 *Member Releases*

2.9 Serviceability Data

The final input table includes different possibilities for the serviceability design. It is only displayed if the serviceability limit state design has been enabled in table 1.1 *General Data* (see figure 2.3, page 10).

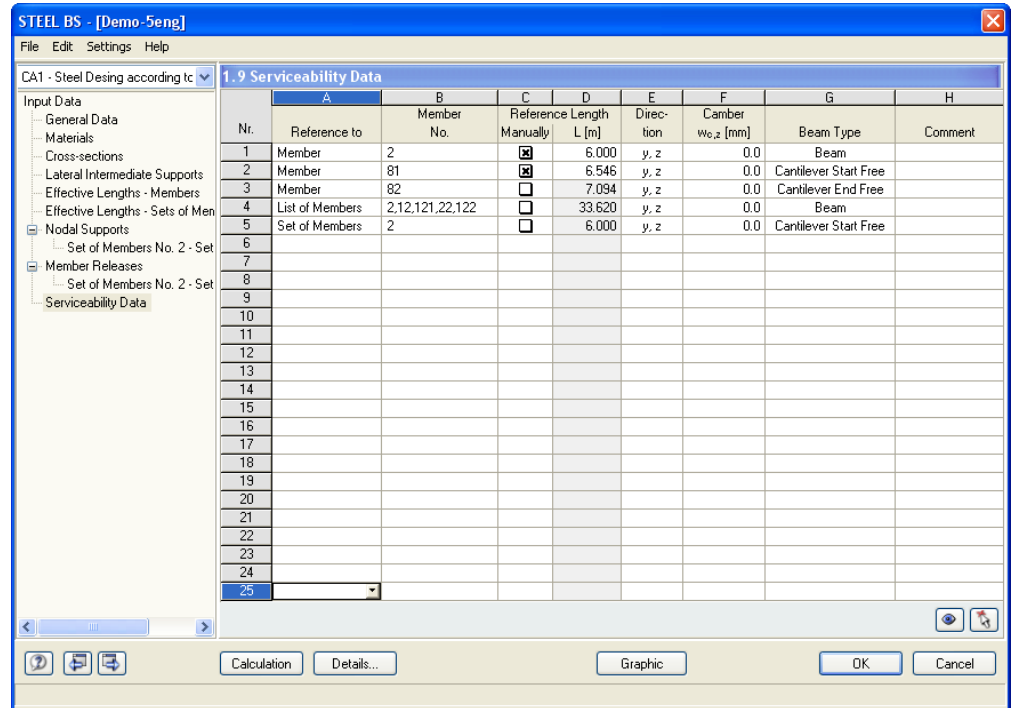

Nr.	Reference to	Member No.	Reference Length L [m]	Manually	Direction	Camber $w_{0,z}$ [mm]	Beam Type	Comment
1	Member	2	6.000	<input checked="" type="checkbox"/>	y, z	0.0	Beam	
2	Member	81	6.546	<input checked="" type="checkbox"/>	y, z	0.0	Cantilever Start Free	
3	Member	82	7.094	<input type="checkbox"/>	y, z	0.0	Cantilever End Free	
4	List of Members	2,12,121,22,122	33.620	<input type="checkbox"/>	y, z	0.0	Beam	
5	Set of Members	2	6.000	<input type="checkbox"/>	y, z	0.0	Cantilever Start Free	
6								
7								
8								
9								
10								
11								
12								
13								
14								
15								
16								
17								
18								
19								
20								
21								
22								
23								
24								
25								

Figure 2.26: Table 1.9 *Serviceability Data*

In column A, you decide whether you want to apply the deformation to single members, lists of members or sets of members.

In table column B, you enter the numbers of the members or sets of members that you want to design. You can also use the [Pick] function to select them graphically in the RSTAB work window. The respective *Reference Length L* will be entered automatically in column D. In this column, the lengths of the member, sets of members or member lists are preset. If required, you can adjust those values after ticking the *Manually* check box in column C.

Table column E defines the governing *Direction* for the deformation analysis. If necessary, a *Camber* Δ_{camb} can be taken into account in column F.

The *Beam Type* (beam or cantilever) is very important to correctly apply the limit deformations. It can be entered in column G.

The settings shown in the *Serviceability* tab of the *Details* dialog box determine whether the deformations are related to the undeformed initial structure or to the shifted ends of members or sets of members (see chapter 3.1, page 29).

Details...

3. Calculation

3.1 Details

Calculation

Details...

A particular design is carried out with the internal forces calculated in the RSTAB program. Before the [Calculation], you should check the detailed setting for the design. Open the appropriate dialog box from every input or output table by clicking the [Details] button.

The *Details* dialog box consists of four tabs: *Ultimate Limit State*, *Stability*, *Serviceability* and *Other*.

Ultimate Limit State

Options

STEEL BS carries out a plastic design for cross-sections of classes 1 or 2. If needed, the *Elastic design* can be activated for those cross-section classes in the *Ultimate Limit State* tab.

Stability

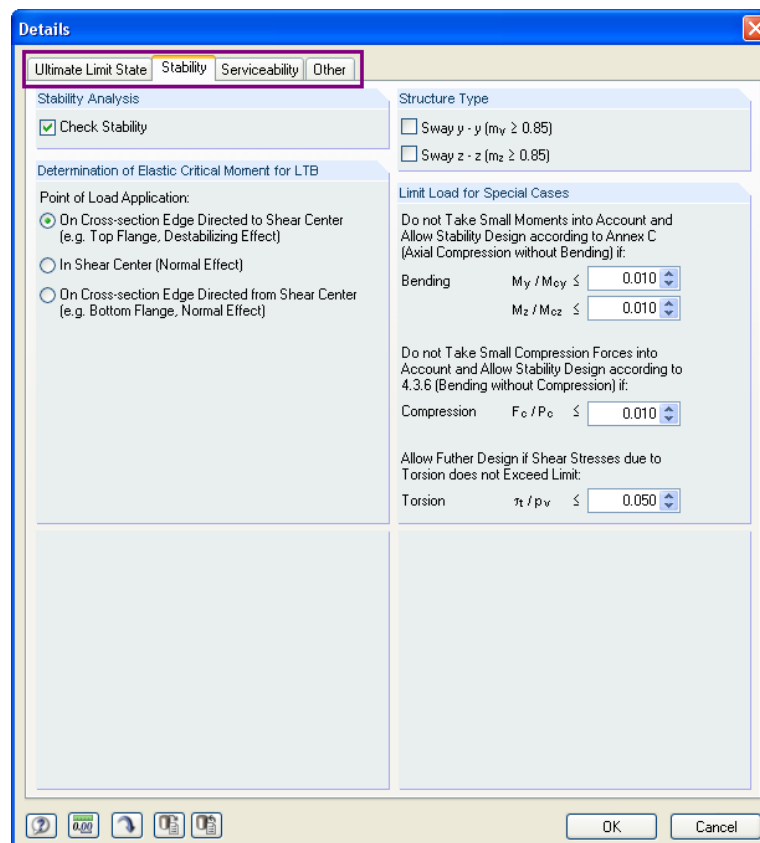

Figure 3.1: *Details* dialog box, tab *Stability*

Stability Analysis

In this section you can decide whether the stability analysis is to be carried out in general. If the check is disabled here, the input tables 1.4 to 1.8 will not be active.

Determination of Elastic Critical Moment for LTB

Usually, loads act on members. Then their application point has to be specified because this can have stabilizing or destabilizing effects, subject to the eccentricity. The *Point of Applied Load* can be set globally for all loads.

The elastic critical stress p_E is calculated automatically for sets of members.

Structure Type

The structure type can be either *Non-sway* or *Sway*, which affects the calculation of m_y and m_z . For a sway-type structure, the values of m_y and m_z are assumed as 0.85.

Limit Load for Special Cases

It is possible to neglect small stresses due to bending compressive forces and torsion and, thus, allow a simplified design which eliminates negligible internal forces. In this dialog section, the limits of these internal forces or stresses can be entered. Those are defined as the ratios between existing internal forces or stresses and the corresponding resistances of each cross-section.

If one of those limits is exceeded, a comment will be given in the results table. There will be no stability design. Nevertheless, the design of the cross-section itself is carried out. Please note that those limit values are not part of the *British Standard*. If you change the limits, it will be in your own area of responsibility.

Serviceability

Serviceability (Deflections)

In this section, it is possible to check or change the allowable deflections for the serviceability limit state design. The default values are $L/360$ for beams and $L/180$ for cantilevers.

The two selection fields below control whether the *Deformation* is to be related to the undeformed model or to an imaginary connecting line between the shifted start and end nodes of the member resp. set of members within the deformed structure.

Other

Cross-section Optimization

Cross-sections can be optimized if the *Optimize* option is chosen in table 1.3 *Cross-Sections*. (see figure 2.10, page 16). The dialog box *Details* enables you to set the maximum allowable design ratio as a limit for the optimization process.

Check of Member Slendernesses

It is possible to set user-defined slenderness ratios KL/r for members with tension resp. compression or flexure. These maximum values are compared with the actual member slendernesses in table 3.3 which is available after the calculation (see chapter 4.8).

Display Results Tables

In this section, the results tables can be specified which are to be displayed, inclusive of a parts list. The results tables are described individually in chapter 4.



3.2 Start Calculation

Calculation

In all input tables of STEEL BS, you can start the design via the [Calculation] button.

At first, STEEL BS searches for the results of the selected load cases, load groups and combinations. If they are not found, the calculation of the governing internal forces in RSTAB is started. The calculation parameters of RSTAB are used for this analysis.

If cross-sections are to be optimized (see chapter 7.2, page 53), the required sections are calculated and relevant types of design are carried out.

The STEEL BS design can be also started from the RSTAB interface. All design cases of the add-on modules are displayed in the *To Calculate* dialog box, similarly to load cases or load groups. Open this dialog box in RSTAB via the main menu

Calculate → To Calculate...

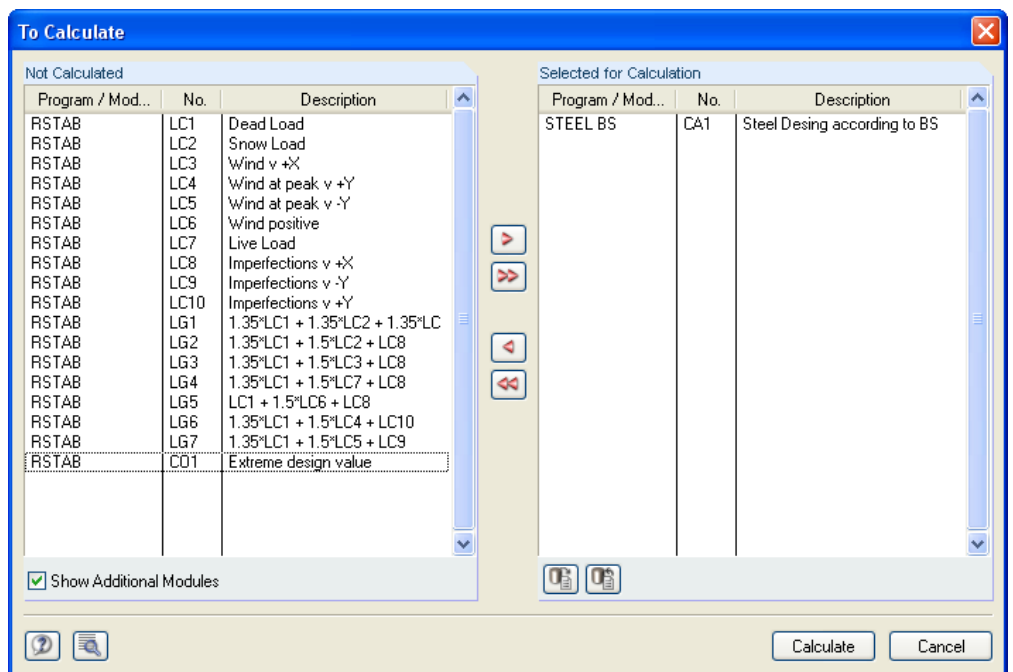

Figure 3.2: To Calculate dialog box

If the design cases of STEEL BS are missing in the list *Not Calculated*, it is necessary to tick the check box *Show Additional Modules*.

The [▶] button transfers selected design cases to the list on the right. You can then start the calculation by the [Calculate] button.

The calculation of a specific STEEL BS design case can also be directly started from the toolbar. Set the required design case in the list and then click on the [Results on/off] button.

▶
Calculate
Results on/off



Figure 3.3: Direct calculation of STEEL BS design case in RSTAB

A dialog box appears in which you can watch the progress of the design.

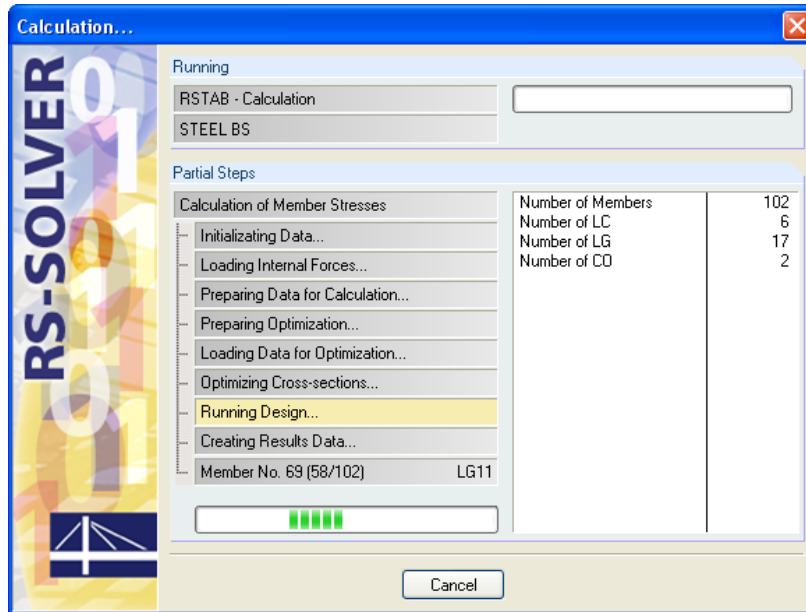

Figure 3.4: Calculation in STEEL BS

4. Results

Immediately after the design, table 2.1 *Design by Load Case* is displayed. The upper part of this table gives a summary of all designs for every load case, load group and combination. The lower part includes all details of the material properties, design internal forces and design data of the load case which is selected in the upper part of the table.

The results tables 2.1 to 2.5 contain the detailed design summaries according to different selection criteria. Tables 3.1 and 3.2 include the governing internal forces. In table 3.3, the member slendernesses are compared with the maximum values as set in the *Details* dialog box. The parts lists are displayed in the last two tables 4.1 and 4.2.

The results tables are accessible from the navigator in STEEL BS. You can also switch among the tables via the buttons as seen to the left or the functional keys [F2] and [F3].

The [OK] button saves the results. The add-on module is STEEL BS 'closed', and you return to the work window of RSTAB.

In this chapter, all results tables are described in the given order. The following chapter 5 *Evaluation of Results* is devoted to the evaluation and checking of results.

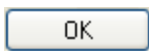

4.1 Design by Load Case

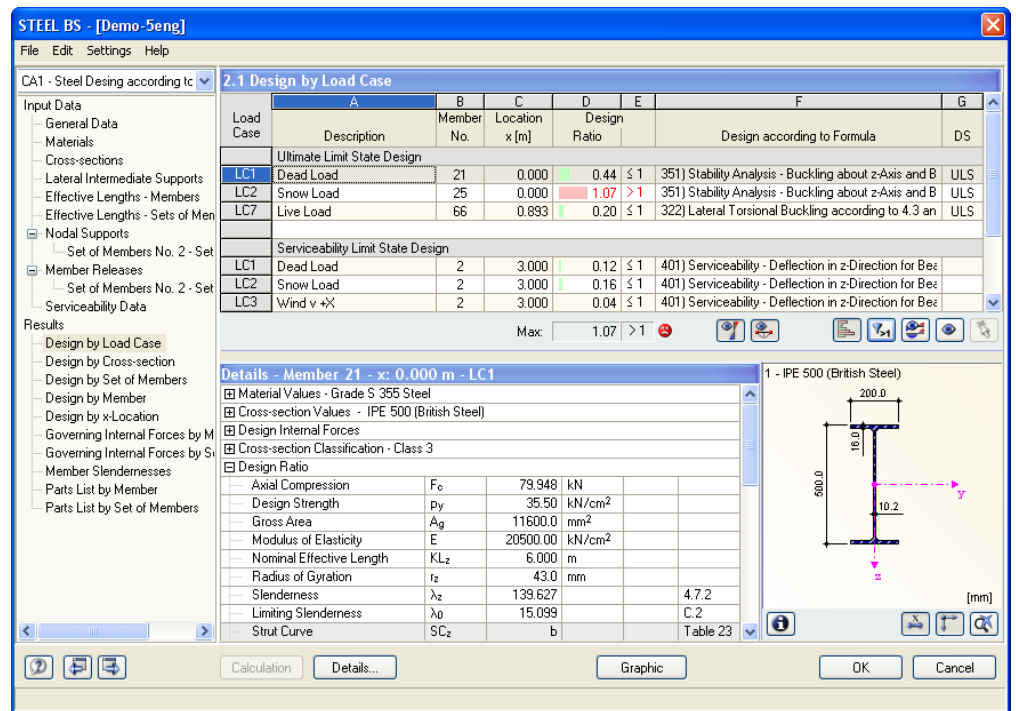

The screenshot shows the STEEL BS software interface. The main window displays the '2.1 Design by Load Case' table. The table has columns for Load Case, Description, Member No., Location x [m], Design Ratio, and Design according to Formula. The table lists several load cases, including Ultimate Limit State Design and Serviceability Limit State Design. The design ratio for LC2 (Snow Load) is highlighted in red as 1.07 > 1. Below the table, the 'Details - Member 21 - x: 0.000 m - LC1' dialog is open, showing material properties for Grade S 355 Steel and IPE 500 (British Steel), including axial compression force, design strength, gross area, modulus of elasticity, and slenderness. A cross-section diagram of the IPE 500 steel beam is also shown.

Load Case	Description	Member No.	Location x [m]	Design Ratio	Design according to Formula	DS
Ultimate Limit State Design						
LC1	Dead Load	21	0.000	0.44 ≤ 1	351) Stability Analysis - Buckling about z-Axis and B	ULS
LC2	Snow Load	25	0.000	1.07 > 1	351) Stability Analysis - Buckling about z-Axis and B	ULS
LC7	Live Load	66	0.893	0.20 ≤ 1	322) Lateral Torsional Buckling according to 4.3 an	ULS
Serviceability Limit State Design						
LC1	Dead Load	2	3.000	0.12 ≤ 1	401) Serviceability - Deflection in z-Direction for Bez	
LC2	Snow Load	2	3.000	0.16 ≤ 1	401) Serviceability - Deflection in z-Direction for Bez	
LC3	Wind v +X	2	3.000	0.04 ≤ 1	401) Serviceability - Deflection in z-Direction for Bez	

Figure 4.1: Table 2.1 *Design by Load Case*

Description

In this column, the descriptions of the load cases, load groups and combinations are displayed that are decisive for every relevant type of design.

Member No.

The number of the member with the highest design ratio is stated for every designed load case, load group or combination.

Location x

The location x on the member where the maximum stress ratio occurs is displayed in this column. The following locations x on the member are taken into account:

- Start and end nodes
- Internal nodes according to potential user-defined member division
- Member division according to specification for member results (*Options* tab of RSTAB dialog box *Calculation Parameters*)
- Extreme values of internal forces

Design Ratio

For every design type and for every load case, load group or combination, the design quotients according to the standard are displayed in this column.

The colored scales represent the design ratios due to the individual load cases.

Design according to Formula

In this column, the equations that were followed in the design are listed.

DS

The final column contains information about the respective design-relevant *Design Situation*: ULS (ultimate limit state) or one of the three design situations for serviceability (*CH*, *FR*, *QP*) according to the specification in table 1.1 *General Data* (see figure 2.3, page 10).

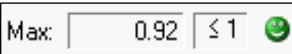

4.2 Design by Cross-Section

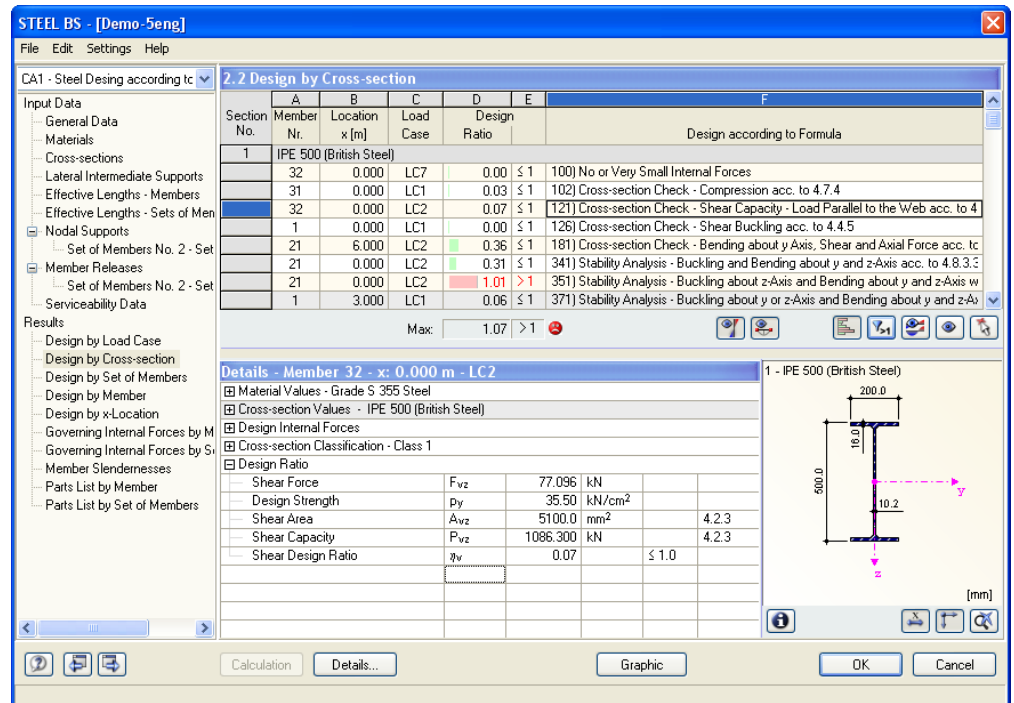

Figure 4.2: Table 2.2 *Design by Cross-Section*

In this table, the maximum design ratios are shown for all designed members and load cases. The results are sorted according to cross-sections.

For tapered members, both cross-section descriptions are shown in the line next to the cross-section number.

4.3 Design by Set of Members

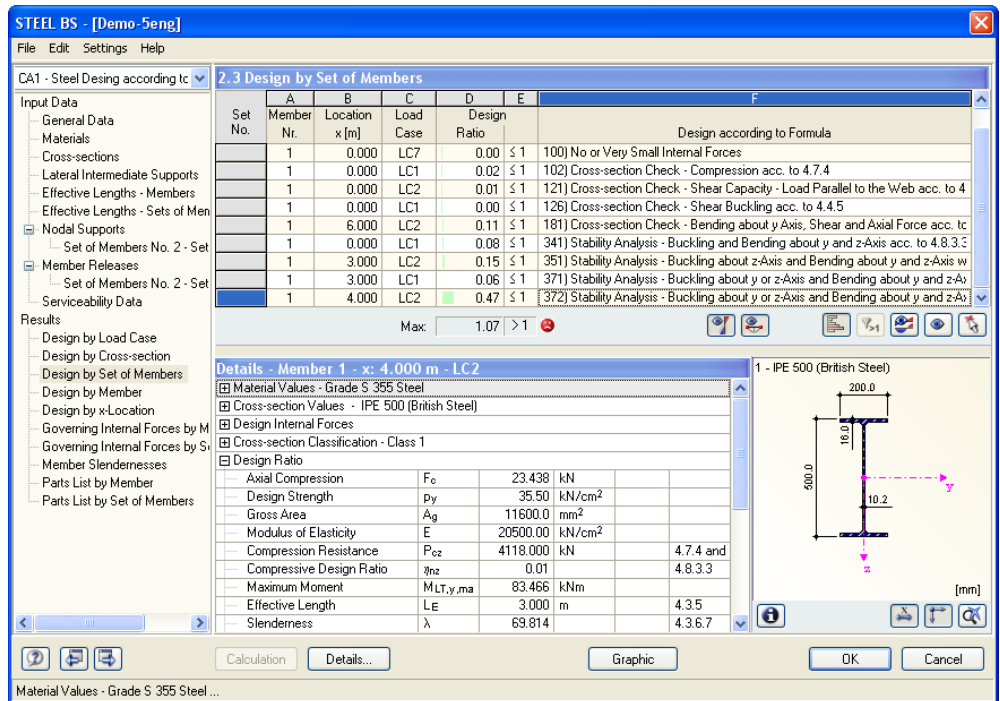

Figure 4.3: Table 2.3 Design by Set of Members

This table is displayed if at least one set of members was selected for design. The maximum design ratios are listed according to sets of members. The number of the member with the highest design ratio within each set of members is shown in the Member Nr. column.

4.4 Design by Member

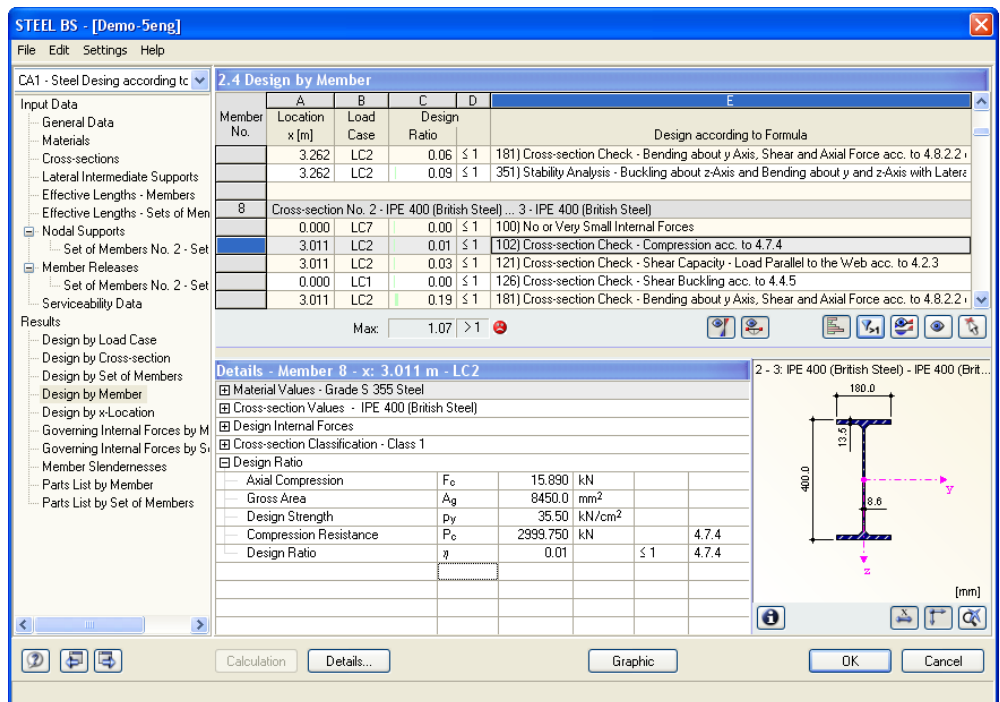

Figure 4.4: Table 2.4 Design by Member

In this table, the maximum design ratios are arranged according to member numbers. The description of the individual columns can be found in chapter 4.1 on page 33.

4.5 Design by x-Location

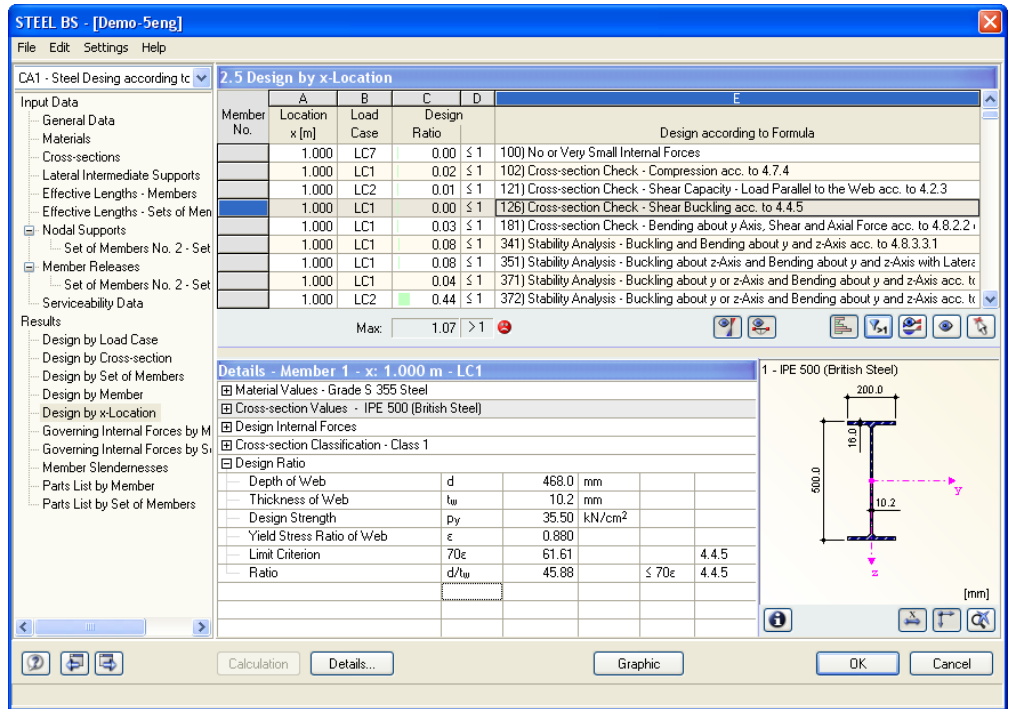

Figure 4.5: Table 2.5 Design by x-Location

This results table lists the maximum values of every member at the following locations x according to the division points of RSTAB:

- Start and end nodes
- Internal nodes according to potential user-defined member division
- Member division according to specification for member results (*Options* tab of RSTAB dialog box *Calculation Parameters*)
- Extreme values of internal forces

4.6 Governing Internal Forces by Member

In this table, the governing internal forces are shown, i.e. those internal forces that lead to the maximum design ratios.

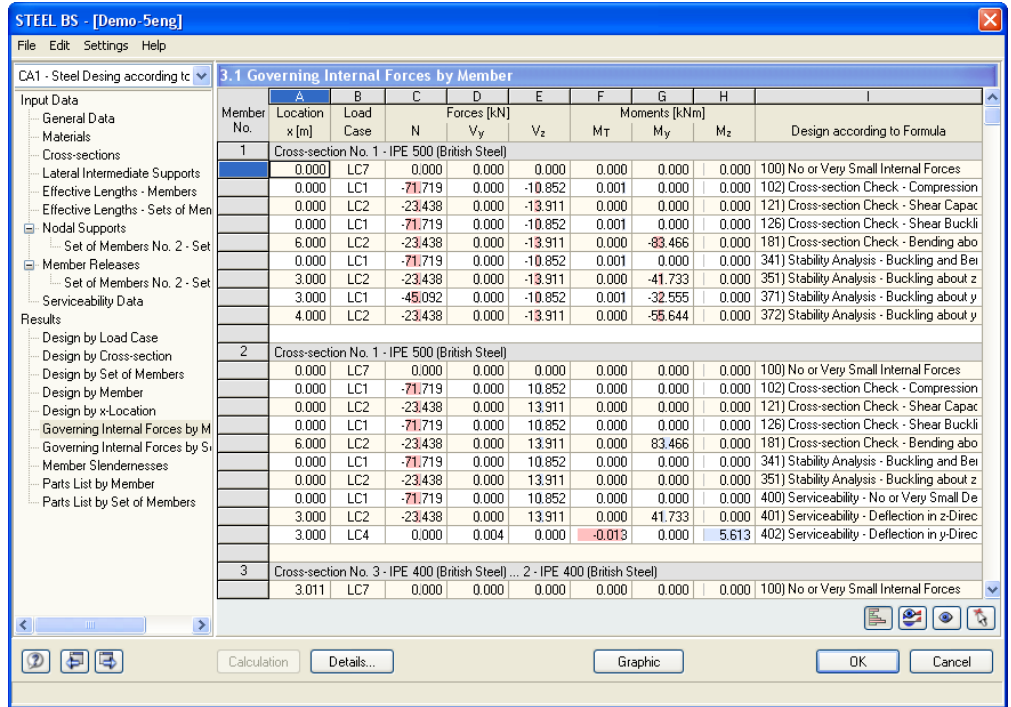

Member No.	Location x [m]	Load Case	Forces [kN]			Moments [kNm]			Design according to Formula
			N	V _y	V _z	M _T	M _y	M _z	
3.1 Governing Internal Forces by Member									
1 Cross-section No. 1 - IPE 500 (British Steel)									
0.000	LC7	0.000	0.000	0.000	0.000	0.000	0.000	0.000	100) No or Very Small Internal Forces
0.000	LC1	-71.719	0.000	-10.852	0.001	0.000	0.000	0.000	102) Cross-section Check - Compression
0.000	LC2	-23.438	0.000	-13.911	0.000	0.000	0.000	0.000	121) Cross-section Check - Shear Capac
0.000	LC1	-71.719	0.000	-10.852	0.001	0.000	0.000	0.000	126) Cross-section Check - Shear Buckli
6.000	LC2	-23.438	0.000	-13.911	0.000	-83.466	0.000	0.000	181) Cross-section Check - Bending abo
0.000	LC1	-71.719	0.000	-10.852	0.001	0.000	0.000	0.000	341) Stability Analysis - Buckling and Bei
3.000	LC2	-23.438	0.000	-13.911	0.000	-41.733	0.000	0.000	351) Stability Analysis - Buckling about z
3.000	LC1	-45.092	0.000	-10.852	0.001	-32.595	0.000	0.000	371) Stability Analysis - Buckling about y
4.000	LC2	-23.438	0.000	-13.911	0.000	-56.644	0.000	0.000	372) Stability Analysis - Buckling about y
2 Cross-section No. 1 - IPE 500 (British Steel)									
0.000	LC7	0.000	0.000	0.000	0.000	0.000	0.000	0.000	100) No or Very Small Internal Forces
0.000	LC1	-71.719	0.000	10.852	0.000	0.000	0.000	0.000	102) Cross-section Check - Compression
0.000	LC2	-23.438	0.000	13.911	0.000	0.000	0.000	0.000	121) Cross-section Check - Shear Capac
0.000	LC1	-71.719	0.000	10.852	0.000	0.000	0.000	0.000	126) Cross-section Check - Shear Buckli
6.000	LC2	-23.438	0.000	13.911	0.000	83.466	0.000	0.000	181) Cross-section Check - Bending abo
0.000	LC1	-71.719	0.000	10.852	0.000	0.000	0.000	0.000	341) Stability Analysis - Buckling and Bei
0.000	LC2	-23.438	0.000	13.911	0.000	0.000	0.000	0.000	351) Stability Analysis - Buckling about z
0.000	LC1	-71.719	0.000	10.852	0.000	0.000	0.000	0.000	400) Serviceability - No or Very Small De
3.000	LC2	-23.438	0.000	13.911	0.000	41.733	0.000	0.000	401) Serviceability - Deflection in z-Direc
3.000	LC4	0.000	0.004	0.000	-0.013	0.000	5.613	0.000	402) Serviceability - Deflection in y-Direc
3 Cross-section No. 3 - IPE 400 (British Steel) ... 2 - IPE 400 (British Steel)									
3.011	LC7	0.000	0.000	0.000	0.000	0.000	0.000	0.000	100) No or Very Small Internal Forces

Figure 4.6: Table 3.1 Governing Internal Forces by Member

Location x

For every member, the location x on the member with the maximum design ratio is shown.

Load Case

In this column, the numbers of the load cases, load groups or combination whose internal forces have the most unfavorable effects are displayed.

Forces / Moments

The decisive axial and shear forces as well as the torsional and bending moments are listed for every member.

Design according to Formula

The last column includes the relevant types of design and equations that were followed in the design.

4.7 Governing Internal Forces by Set of Members

Set No.	Location x [m]	Load Case	Forces [kN]			Moments [kNm]			Design according to Formula
			N	V _y	V _z	M _T	M _y	M _z	
2	0.000	LC7	0.000	0.000	0.000	0.000	0.000	0.000	100) No or Very Small Internal Forces
	0.000	LC1	-71.719	0.000	-10.852	0.001	0.000	0.000	102) Cross-section Check - Compression ac
	0.000	LC2	-23.438	0.000	-13.911	0.000	0.000	0.000	121) Cross-section Check - Shear Capacity
	0.000	LC1	-71.719	0.000	-10.852	0.001	0.000	0.000	126) Cross-section Check - Shear Buckling
	6.000	LC2	-23.438	0.000	-13.911	0.000	-83.466	0.000	181) Cross-section Check - Bending about y
	0.000	LC1	-71.719	0.000	-10.852	0.001	0.000	0.000	341) Stability Analysis - Buckling and Bendr
	3.000	LC2	-23.438	0.000	-13.911	0.000	-41.733	0.000	351) Stability Analysis - Buckling about z:Ax
	3.000	LC1	-45.092	0.000	-10.852	0.001	-32.555	0.000	371) Stability Analysis - Buckling about y or z
	4.000	LC2	-23.438	0.000	-13.911	0.000	-55.644	0.000	372) Stability Analysis - Buckling about y or z

Figure 4.7: Table 3.2 Governing Internal Forces by Set of Members

In this results table, the governing internal forces that lead to the maximum design ratios of every set of members are shown.

4.8 Member Slendernesses

Member No.	Under Stress	Length L [m]	K _y	Major Axis y		K _z	Minor Axis z	
				r _y [mm]	K _{L_y / r_y}		r _z [mm]	K _{L_z / r_z}
1	Compression/Flexure	6.000	1.000	203.8	29.435	0.500	43.0	69.814
2	Compression/Flexure	6.000	1.000	203.8	29.435	1.000	43.0	139.627
3	Compression/Flexure	3.011	1.000	165.0	18.253	0.250	39.5	19.065
4	Compression/Flexure	3.262	1.000	165.4	19.719	1.000	39.5	82.607
5	Compression/Flexure	6.274	1.000	165.4	37.921	1.000	39.5	158.860
6	Compression/Flexure	6.274	1.000	165.4	37.921	1.000	39.5	158.860
7	Compression/Flexure	3.262	1.000	165.4	19.719	1.000	39.5	82.607
8	Compression/Flexure	3.011	1.000	165.0	18.253	1.000	39.5	76.258
11	Compression/Flexure	6.000	1.000	203.8	29.435	1.000	43.0	139.627
12	Compression/Flexure	6.000	1.000	203.8	29.435	1.000	43.0	139.627
13	Compression/Flexure	3.011	1.000	165.0	18.253	1.000	39.5	76.258
14	Compression/Flexure	3.262	1.000	165.4	19.719	1.000	39.5	82.607
15	Compression/Flexure	6.274	1.000	165.4	37.921	1.000	39.5	158.860
16	Compression/Flexure	6.274	1.000	165.4	37.921	1.000	39.5	158.860
17	Compression/Flexure	3.262	1.000	165.4	19.719	1.000	39.5	82.607
18	Compression/Flexure	3.011	1.000	165.0	18.253	1.000	39.5	76.258
21	Compression/Flexure	6.000	1.000	203.8	29.435	1.000	43.0	139.627
22	Compression/Flexure	6.000	1.000	203.8	29.435	1.000	43.0	139.627
23	Compression/Flexure	3.011	1.000	165.0	18.253	1.000	39.5	76.258
24	Compression/Flexure	3.262	1.000	165.4	19.719	1.000	39.5	82.607
25	Compression/Flexure	6.274	1.000	165.4	37.921	1.000	39.5	158.860
26	Compression/Flexure	6.274	1.000	165.4	37.921	1.000	39.5	158.860

Figure 4.8: Table 3.3 Member Slendernesses

In table 3.3, the effective slenderness ratios of all designed members are compared with the maximum values that were set in the *Details* dialog box (see chapter 3.1). These ratios are listed with respect to the major and minor principal axes. This table provides information on the maximum effective slenderness ratios only, it does not give any design results.

Members of the types "Tension" or "Cable" are excluded from this table.

4.9 Parts List by Member

Finally, the parts list of all cross-sections that are considered in the design case is displayed.

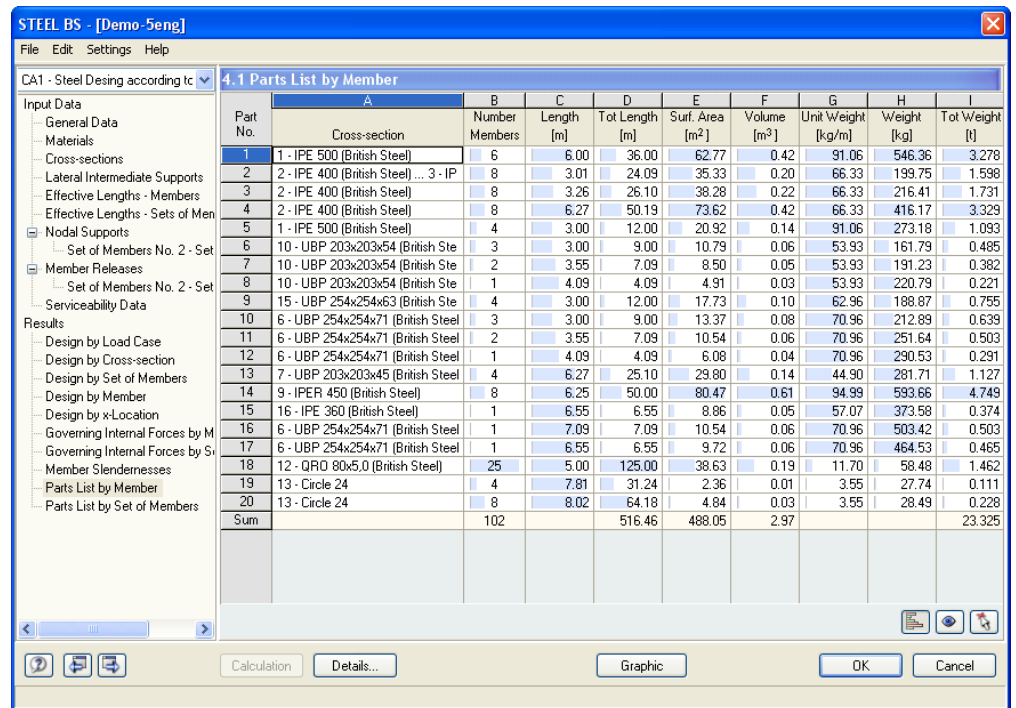

Part No.	A Cross-section	B Number Members	C Length [m]	D Tot Length [m]	E Surf. Area [m ²]	F Volume [m ³]	G Unit Weight [kg/m]	H Weight [kg]	I Tot Weight [t]
1	1 - IPE 500 (British Steel)	6	6.00	36.00	62.77	0.42	91.06	546.36	3.278
2	2 - IPE 400 (British Steel) ... 3 - IP	8	3.01	24.09	35.33	0.20	66.33	199.75	1.598
3	2 - IPE 400 (British Steel)	8	3.26	26.10	38.28	0.22	66.33	216.41	1.731
4	2 - IPE 400 (British Steel)	8	6.27	50.19	73.62	0.42	66.33	416.17	3.329
5	1 - IPE 500 (British Steel)	4	3.00	12.00	20.92	0.14	91.06	273.18	1.093
6	10 - UBP 203x203x54 (British Ste	3	3.00	9.00	10.79	0.06	53.93	161.79	0.485
7	10 - UBP 203x203x54 (British Ste	2	3.55	7.09	8.50	0.05	53.93	191.23	0.382
8	10 - UBP 203x203x54 (British Ste	1	4.09	4.09	4.91	0.03	53.93	220.79	0.221
9	15 - UBP 254x254x63 (British Ste	4	3.00	12.00	17.73	0.10	62.96	188.87	0.755
10	6 - UBP 254x254x71 (British Steel	3	3.00	9.00	13.37	0.08	70.96	212.89	0.639
11	6 - UBP 254x254x71 (British Steel	2	3.55	7.09	10.54	0.06	70.96	251.64	0.503
12	6 - UBP 254x254x71 (British Steel	1	4.09	4.09	6.08	0.04	70.96	290.53	0.291
13	7 - UBP 203x203x45 (British Steel	4	6.27	25.10	29.80	0.14	44.90	281.71	1.127
14	9 - IPE 450 (British Steel)	8	6.25	50.00	80.47	0.61	94.99	593.66	4.749
15	16 - IPE 360 (British Steel)	1	6.55	6.55	8.86	0.05	57.07	373.58	0.374
16	6 - UBP 254x254x71 (British Steel	1	7.09	7.09	10.54	0.06	70.96	503.42	0.503
17	6 - UBP 254x254x71 (British Steel	1	6.55	6.55	9.72	0.06	70.96	464.53	0.465
18	12 - QRD 80x5.0 (British Steel)	25	5.00	125.00	38.63	0.19	11.70	58.48	1.462
19	13 - Circle 24	4	7.81	31.24	2.36	0.01	3.55	27.74	0.111
20	13 - Circle 24	8	8.02	64.18	4.84	0.03	3.55	28.49	0.228
Sum		102		516.46	488.05	2.97			23.325

Figure 4.9: Table 4.1 *Parts List by Member*

[Details...](#)

This list contains only designed members by default. If all members of the structure are to be included, you can change the settings in the *Other* tab of the *Details* dialog box (see chapter 3.1). This dialog box is accessible via the [Details] button.

Part No.

The same part number is automatically assigned to identical members.

Cross-section

In this column, the cross-section description is displayed.

Number of Members

The number of identical members is given for each part.

Length

This column displays the unit lengths of every single member.

Total Length

This column represents the product of the values given in the two previous columns.



Surface Area

The surface area which is related to the total length of the relevant part is calculated on the basis of the value A_{Surf} of each cross-section. You can check on this value by clicking on the [Info about Current Cross-Section] button in tables 1.3 or 2.1 to 2.5.

Volume

The volume of every part is calculated from the surface area and the total length.

Unit Weight

The *Unit Weight* of the cross-section represents the weight per length of 1 m. For tapered cross-sections, the unit weight is calculated as the mean value of both cross-sections.

Weight

The value in this column is calculated as the product of values in the columns C and G.

Total Weight

The total weight of each part is displayed in the last column.

Sum

The sums of the values listed in columns B, D, E, F and I are given in the final row of the list. The cell *Total Weight* shows the total required mass of steel.

4.10 Parts List by Set of Members

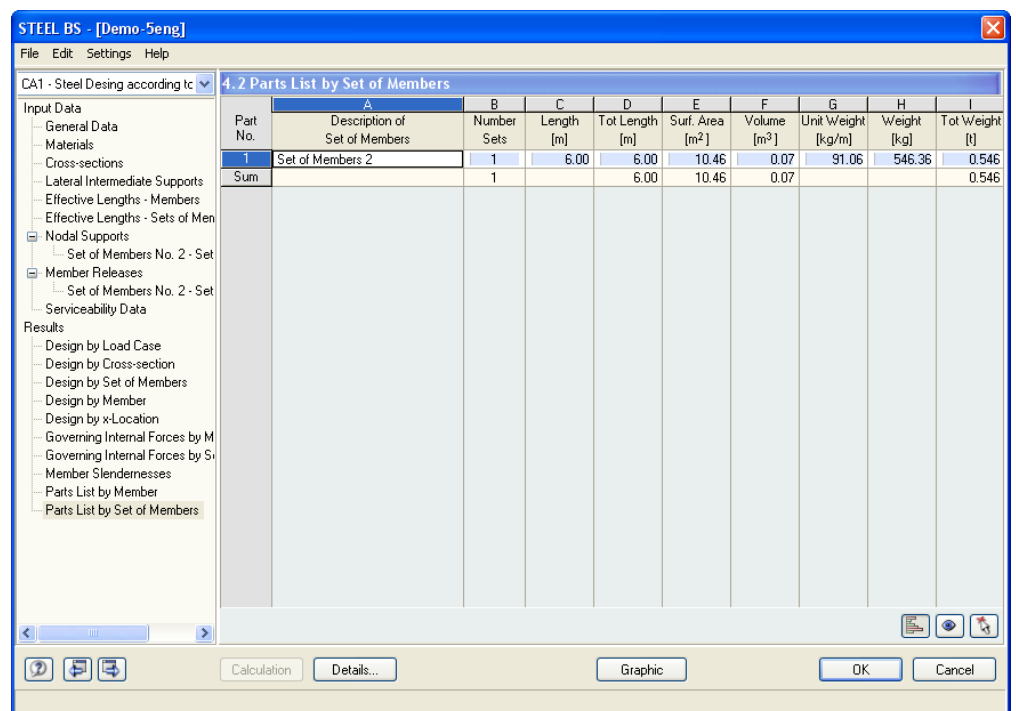

Part No.	Description of Set of Members	Number Sets	Length [m]	Tot Length [m]	Surf. Area [m ²]	Volume [m ³]	Unit Weight [kg/m]	Weight [kg]	Tot Weight [t]
1	Set of Members 2	1	6.00	6.00	10.46	0.07	91.06	546.36	0.546
Sum		1		6.00	10.46	0.07			0.546

Figure 4.10: Table 4.2 *Parts List by Set of Members*

The last table in STEEL BS is presented when at least one set of members was selected for the design. The advantage of this table is that a parts list is given for the various groups of elements (e.g. for a beam).

The table columns are described in chapter 4.9. If there are different cross-sections within the set of members, the mean values of surface area, volume and unit weight are listed.

5. Evaluation of Results

The design results can be evaluated in different ways. For this, the buttons in the results tables are very useful which are located below the upper tables.

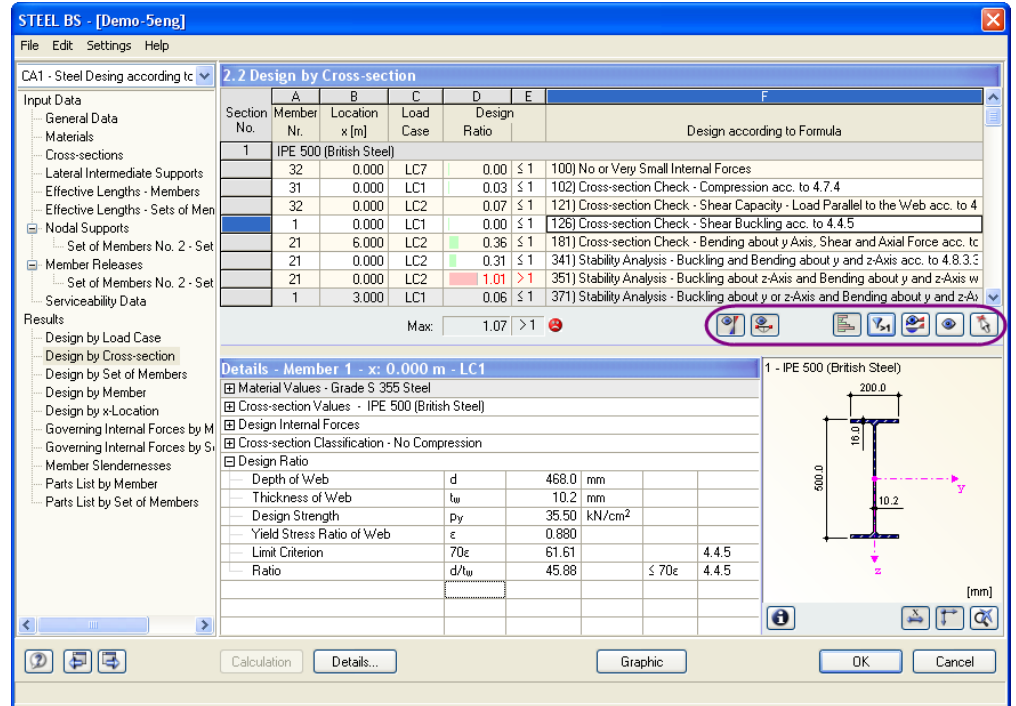

Figure 5.1: Buttons for evaluation of results

These buttons have the following functions:







Button	Name	Function
	Design of Ultimate Limit State	Switch on/off the design results of the ultimate limit state
	Design of Serviceability Limit State	Switch on/off the design results of the serviceability limit state
	Show Color Bars in Table	Switch on/off the color background in the results tables according to the reference scale
	Show Rows with Ratio > 1	Show only rows with stress ratios greater than 1 and, accordingly, failed design
	Show Result Diagrams of Current Member	Open the diagram <i>Result Diagram on Member</i> → chapter 5.2, page 46
	Jump to Graphics to Change View	Go to the RSTAB work window in order to change the display settings
	Pick Member in Graphics and Go to This Member in Table	Click on a specific member in the RSTAB window whose result values are to be displayed in the table

Table 5.1: Buttons in results tables 2.1 to 2.5

5.1 Results on RSTAB Model

You can use the RSTAB work window to evaluate the design results.

RSTAB background graphic and view mode

The RSTAB graphics in the background can be useful if you want to check the location of a particular member in the model. The member that is selected in the STEEL BS results table is also highlighted in the selection color in the RSTAB background graphic. Additionally, an arrow marks the member location x which is stated in the active table row.

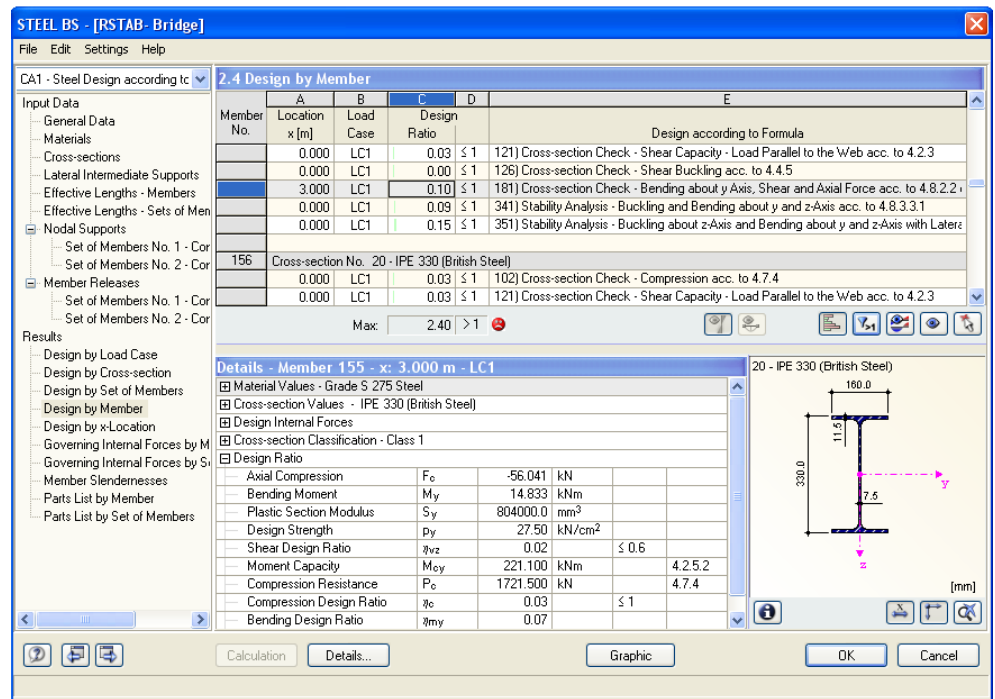
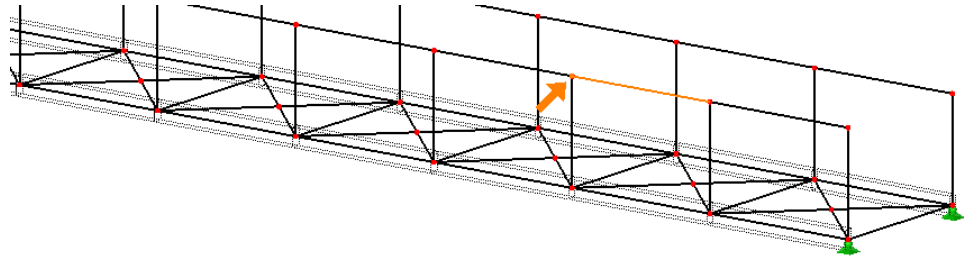

Figure 5.2: Selection of member and current Location x in RSTAB model

If you move the STEEL BS window to another place in the display and still cannot see the graphic clearly, use the so-called *View Mode* by clicking on the [Change View] button. The STEEL BS window will be hidden so that you can adjust the view in the RSTAB interface appropriately. The view mode provides the functions of the *View* menu, for example zooming, moving or rotating the display.

Click [Back] to return to the add-on module STEEL BS.

RSTAB work window

It is also possible to visualize the design ratios directly in the structural model: Click the [Graphic] button to quit the add-on module STEEL BS. The ratios are displayed in the RSTAB work window like internal forces of a load case.



Information

You are in the view mode.

Back



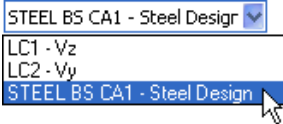

To turn the display of design results on or off, use the button [Results on/off] shown on the left. To display the result values in the graphic, use the toolbar button [Show Result Values] to the right.

As the RSTAB tables are of no relevance for the evaluation of STEEL BS results, you may deactivate them.

The design cases can be set as usual by means of the list in the RSTAB menu bar.

The graphical display of results can be set in the *Display* navigator by opening the *Results* folder and selecting the *Members* entry. By default, the ratios are shown *Two-Colored*.

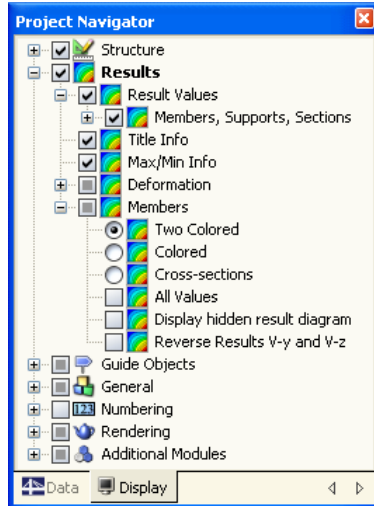

Figure 5.3: *Display* navigator: Results → Members → **Two Colored**



If you select the *Colored* results display, the panel colors becomes available with various options for the multicolor display. Those are described in chapter 4.4.6 of the RSTAB manual.

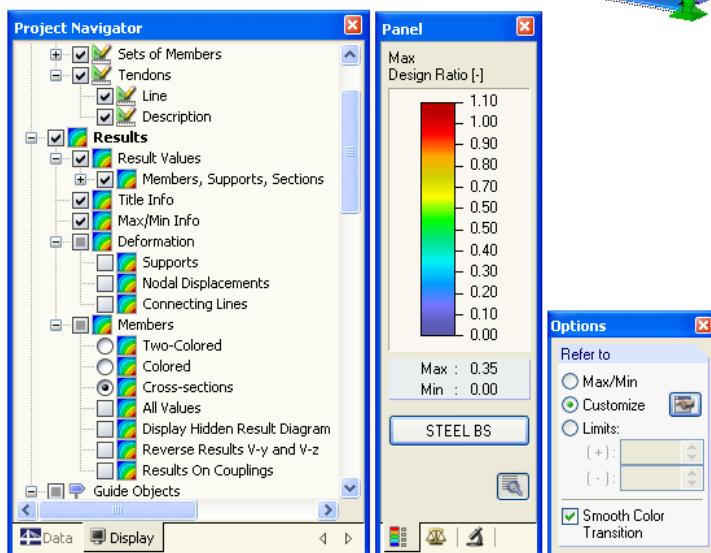
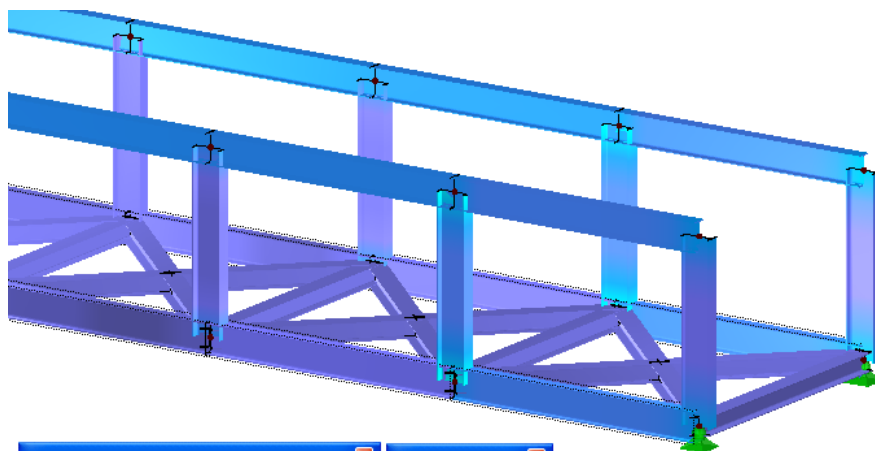

Figure 5.4: Design ratios with option *Cross-sections* in *Display* navigator

In the *Factors* tab, you can scale the design results, as you know it from the member internal forces. If you enter the factor *0* in the input field *Member Diagrams*, the results will be represented without scaling but with an increased line thickness.

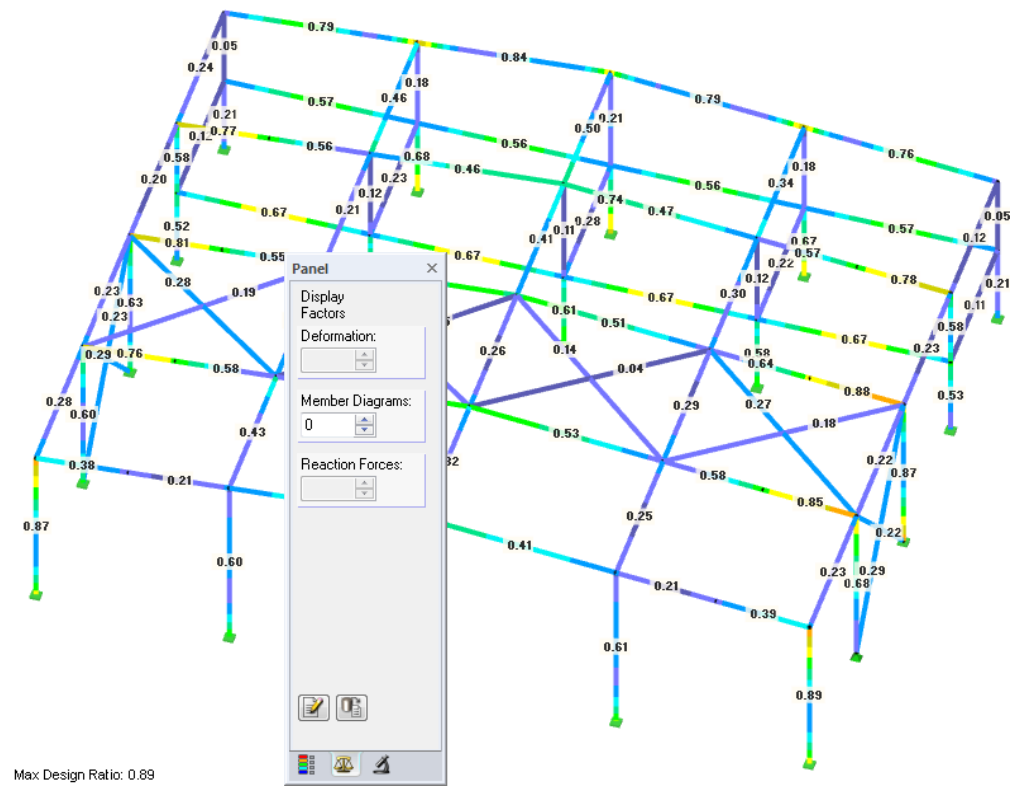

Figure 5.5: Panel tab *Factors*

The graphics can be transferred like RSTAB graphics to the printout report (see chapter 6.2 on page 49).

STEEL BS

To return to the add-on module STEEL BS, use the [STEEL BS] button in the panel.

5.2 Result Diagrams



In order to view the detailed distribution of results of a specific member, the graph of results can be used. Select the relevant member or set of members in the results table of STEEL BS and then activate the diagram by the button as seen to the left. This button is located below the upper tables of results.

The result diagrams are available in the RSTAB window via the main menu

Results → Member Results

or by using the corresponding button in the toolbar.



A new window is opened in which the result diagrams of the selected member or set of members are shown.

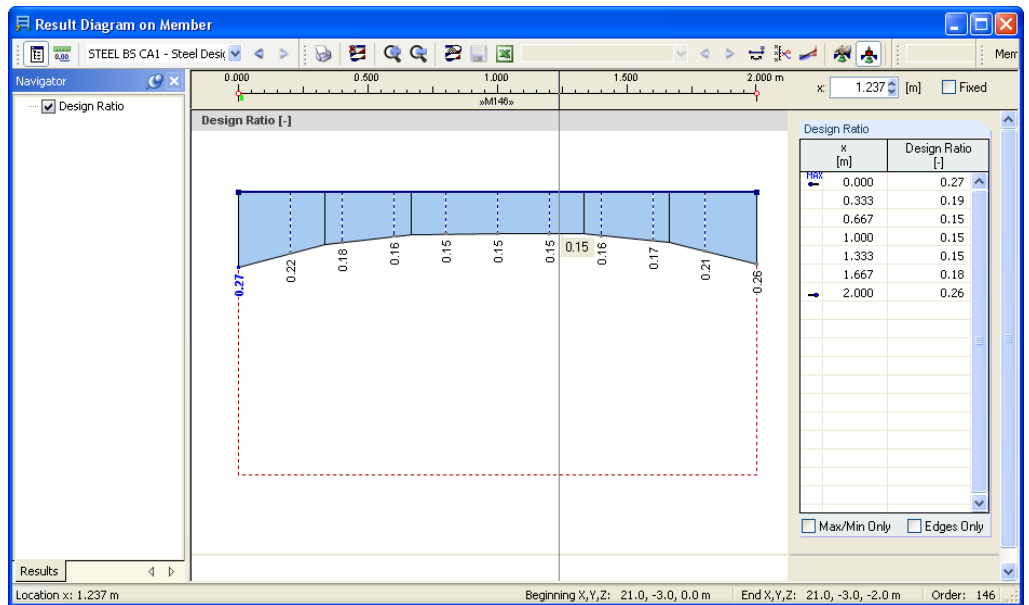
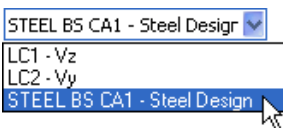

Figure 5.6: Result Diagram on Member dialog box



A particular design case can be selected from the list in the toolbar.

The *Result Diagram on Member* dialog box is described in detail in chapter 9.8.4 of the RSTAB manual.

5.3 Filter Results

The structure of the STEEL BS tables makes it already possible to select the results according to certain criteria. Additionally, you can use the filter functions as described in the RSTAB manual to graphically evaluate the STEEL BS results.

Firstly, you can use already defined partial views (cf RSTAB manual, chapter 9.8.6) that group certain objects in a favorable way.

Secondly, you can set the stress ratios as criteria for filtering the results in the RSTAB work window. For this, the so-called control panel is to be displayed. If it is not visible, you can switch it on in the main menu

View → Control panel

or by clicking on the corresponding button in the *Results* toolbar.

This panel is described in chapter 4.4.6 of the RSTAB manual. The settings to filter the results are defined in the *Color Spectrum* tab of the panel. As this register is not available in case of the two colored stress display, it can be switched on by selecting one of the display options *Colored* or *Cross-Sections* in the *Display* navigator.

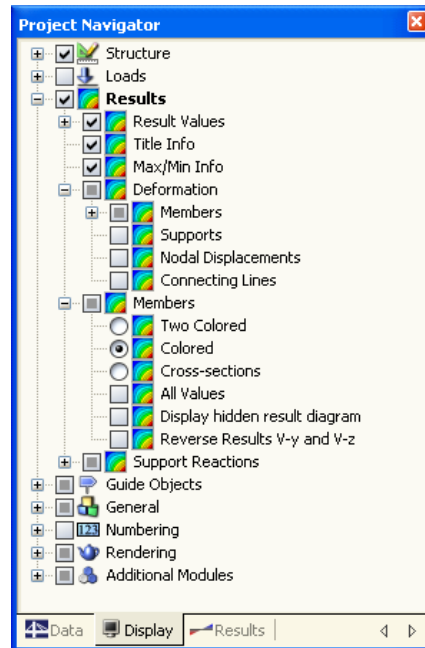

Figure 5.7: *Display* navigator: Results → Members → Colored

For a colored view of the results, you can set in the panel that e.g. only design ratios greater than 0.1 are to be displayed. Furthermore, you can adjust the color spectrum in a way that one single color range exactly covers the design ratio 0.1 (see figure 5.8).

By the option *Display hidden result diagram* (*Display* navigator, entry Results → Members), you can also display design results that do not satisfy the given conditions. Those design diagrams will then be drawn as dashed lines.

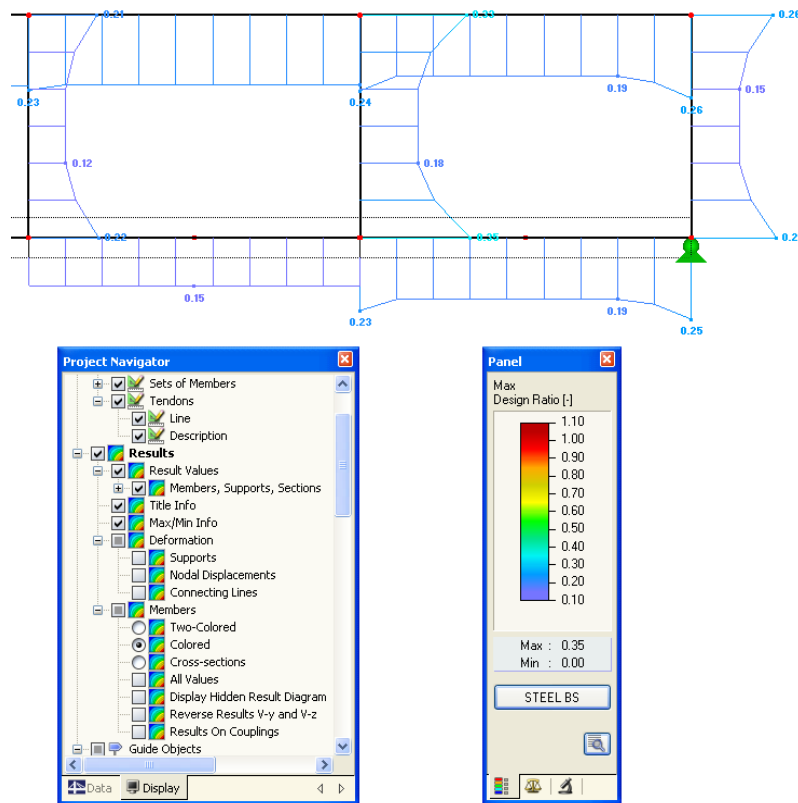

Figure 5.8: Filtering of stress ratios with adjusted color spectrum

Filtering Members



In the *Filter* tab of the control panel, you can enter the numbers of the members whose design ratios are to be shown in the graphics. This function is described in chapter 9.8.6 of the RSTAB manual.

Contrary to the partial view function, the entire structure is displayed here. The following figure shows the design ratios in the compressed flange of a footbridge. The other members of this structure are also shown in the model but they are without any design ratios.

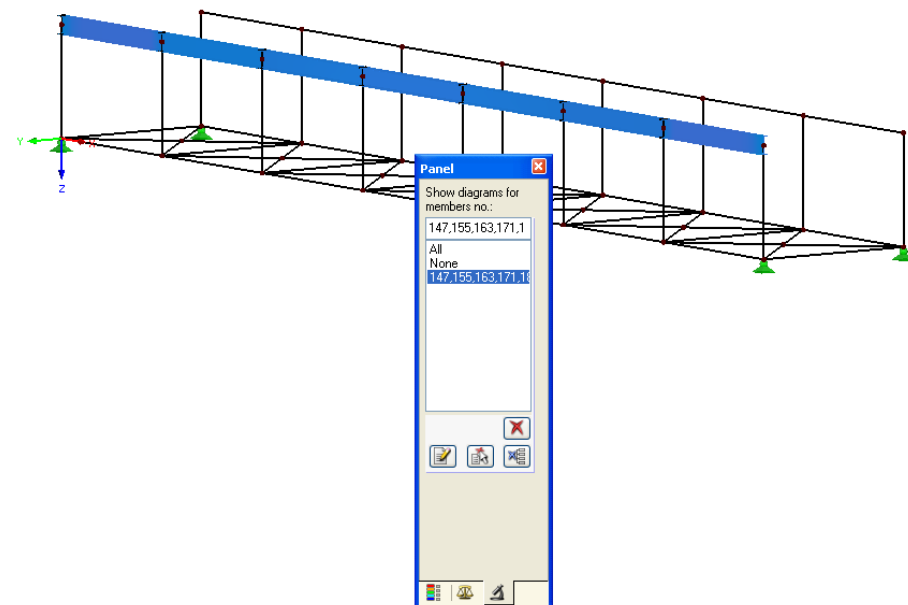

Figure 5.9: Filtering members: design ratios of footbridge flange

6. Printout

6.1 Printout Report

For the design results of STEEL BS, a printout report can be created to which you can add graphics and comments. In this printout report, it is also possible to select the results tables of STEEL BS that are to be printed.

The printout report is described in detail in the manual of the RSTAB program. In particular, chapter 10.1.3.4 *Selecting Data of Add-on Modules* on page 227 is important. It deals with the selection of input and output data in all add-on modules.

For complex structures with a high number of design cases, it is recommended to split the data into several small printout reports which allows for a clearly-arranged printout and a faster work.

6.2 Print STEEL BS Graphics

Every picture that is displayed in the graphic window of the main program RSTAB can be included in the printout report. This means that the design ratios displayed in the RSTAB model can be prepared for the printout, too. The graphics can be integrated in the global printout report or sent directly to the printer. Printing graphics is described in detail in the RSTAB manual, chapter 10.2.

Design results in RSTAB model



To print the STEEL BS graphic that is currently displayed in the RSTAB work window, select **Print** on the **File** menu or use the toolbar button shown on the left.

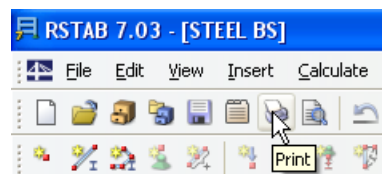

Figure 6.1: *Print* button in toolbar of main window

Result diagrams



You can also print the result diagrams of members by clicking on the [Print] button in the *Result Diagram on Member* window.

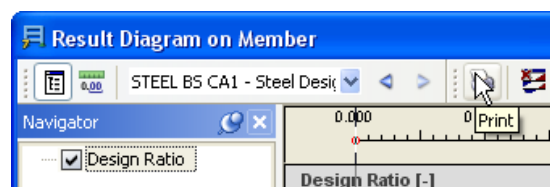

Figure 6.2: *Print* button in toolbar of *Result Diagram* window

The following dialog box opens.

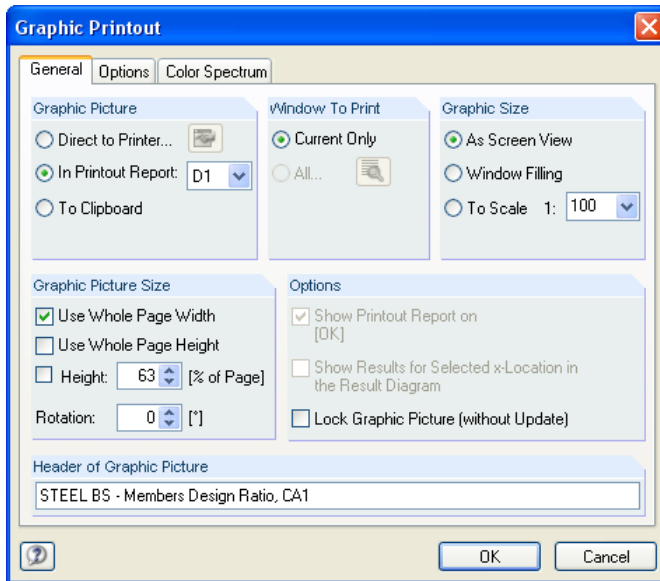

Figure 6.3: *Graphic Printout* dialog box, *General* tab

This dialog box is described in detail in chapter 10.2 on page 243 in the RSTAB manual. The remaining two tabs *Options* and *Color Spectrum* are also explained there.

A STEEL BS graphic that has been integrated in the printout report can be moved anywhere within the report by using the drag-and-drop function. In addition, it is possible to adjust imported graphics subsequently: Right-click the relevant entry in the navigator of the printout report and select *Properties* in the context menu. The dialog box *Graphic Printout* appears again, offering various options for adjustment.

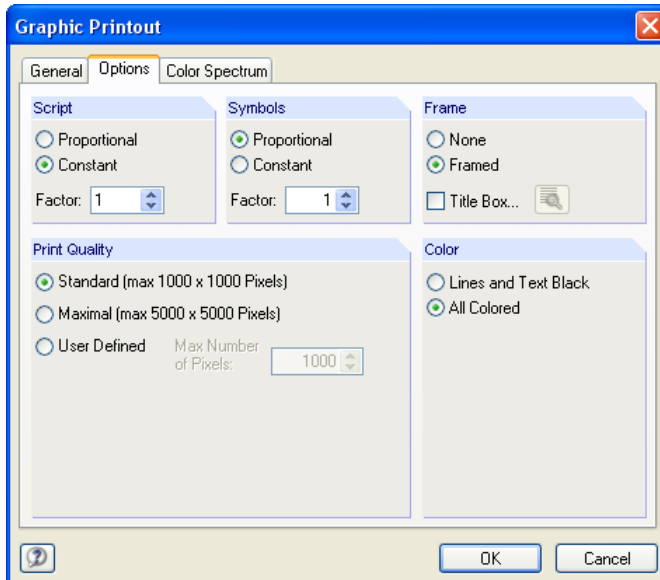
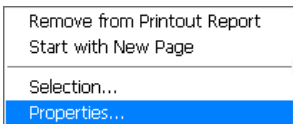

Figure 6.4: *Graphic Printout* dialog box, *Options* tab

7. General Functions

This chapter describes some menu functions and export options of the design results.

7.1 STEEL BS Design Cases

Members can be arranged in groups for different design cases. In this way, you can combine groups of structural components or analyze members with particular design specifications (for example changed materials, partial safety factors, optimization).

It is no problem to analyze the same member or set of members in different design cases.

The STEEL BS design cases are available in the RSTAB work window and can be displayed like a load case or load group by means of the toolbar list.

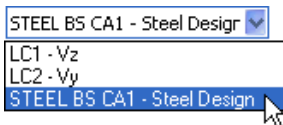

Create a new STEEL BS case

To create a new design case,

select **New Case** on the **File** menu in the STEEL BS add-on module.

The following dialog box appears.

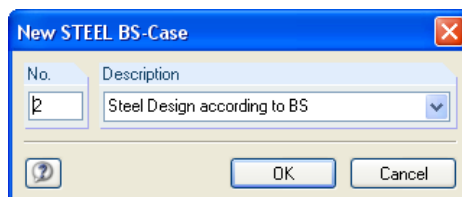

Figure 7.1: *New STEEL BS-Case* dialog box

In this dialog box, enter a *No.* (which is not yet assigned) and a *Description* for the new design case. When you click [OK], table 1.1 *General Data* opens where you can enter the new design data.

Rename a STEEL BS case

To change the description of a design case subsequently,

select **Rename Case** on the **File** menu in the STEEL BS add-on module.

The dialog box *Rename STEEL BS-Case* appears.

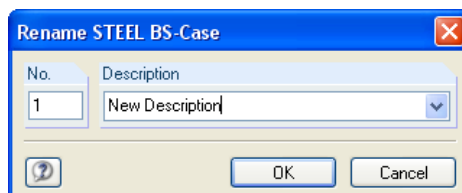

Figure 7.2: *Rename STEEL BS-Case* dialog box

Copy a STEEL BS case

To copy the input data of the current design case,

select **Copy Case** on the **File** menu in the STEEL BS add-on module.

The dialog box *Copy STEEL BS-Case* appears where you can specify the number and description of the new case.

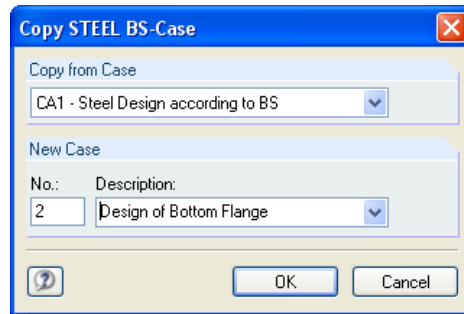

Figure 7.3: *Copy STEEL BS-Case* dialog box

Delete STEEL BS Case

To delete design cases,

select **Delete Case** on the **File** menu in the STEEL BS add-on module.

In the dialog box *Delete Cases*, you can select the relevant design case in the *Available Cases* list to delete it by clicking [OK].

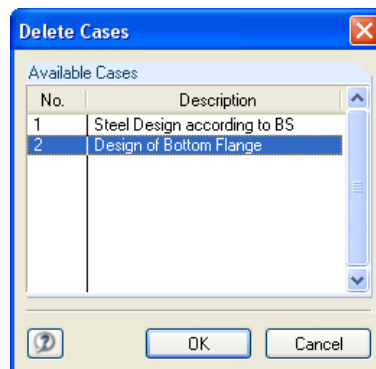
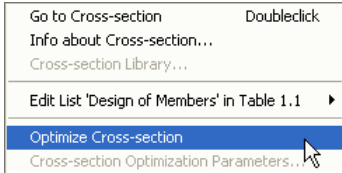

Figure 7.4: *Delete Cases* dialog box

7.2 Cross-Section Optimization

As mentioned in chapter 2.3, STEEL BS offers you the possibility to optimize cross-sections. Select the relevant cross-section by ticking its check box in column D or E in table 1.3 *Cross-sections* (see figure 2.10, page 16).

You can also start the cross-section optimization via the context menu in the results tables.



During the optimization, STEEL BS determines the cross-section within the same cross-sections table that fulfills the analysis requirements in the "optimal" way, i.e. comes as close as possible to the maximum possible ratio specified in the *Details* dialog box, tab *Other* (see chapter 3.1). The required cross-section properties will be determined with the internal forces of RSTAB. If another cross-section proves to be more favorable, it will be used for the design. In this case, two cross-sections will be displayed on the right of table 1.3 as shown in figure 7.6 – the original cross-section from RSTAB and the optimized one.

For parameterized cross-sections of the cross-section library, a dialog box with detailed specifications appears when you tick the check box for optimization.

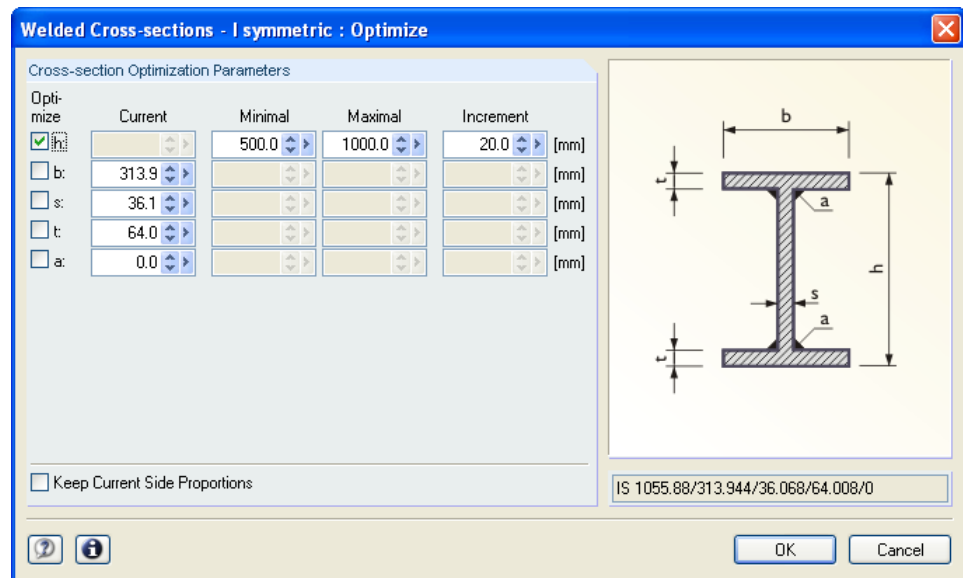

Figure 7.5: *Welded Cross-Sections - I-Symmetric: Optimize* dialog box

By ticking the check boxes in the *Optimize* column, you decide which parameter(s) you want to modify. The ticked check box enables the *Minimal* and *Maximal* columns where you specify the upper and lower limits of the parameter. The *Increment* column determines the interval in which the size of this parameter varies during the optimization process.

If you want to *Keep Current Side Proportions*, tick the corresponding check box. In addition, you have to select at least two parameters for the optimization.

Cross-sections composed of rolled cross-sections cannot be optimized.



Please note for the optimization process that the internal forces won't be recalculated automatically with the changed cross-sections. It is up to you to decide which cross-sections should be transferred to RSTAB for a recalculation. As a result of optimized cross-sections, internal forces may vary considerably because of the changed stiffnesses in the structural system. It is recommended to recalculate the internal forces after the first optimization and then to optimize the cross-sections again.

You do not need to transfer the modified cross-sections to RSTAB manually: Set table 1.3 *Cross-sections*, and then

select **Export All Cross-sections to RSTAB** on the **Edit** menu.

The context menu in table 1.3 also provides options to export optimized cross-sections to RSTAB.

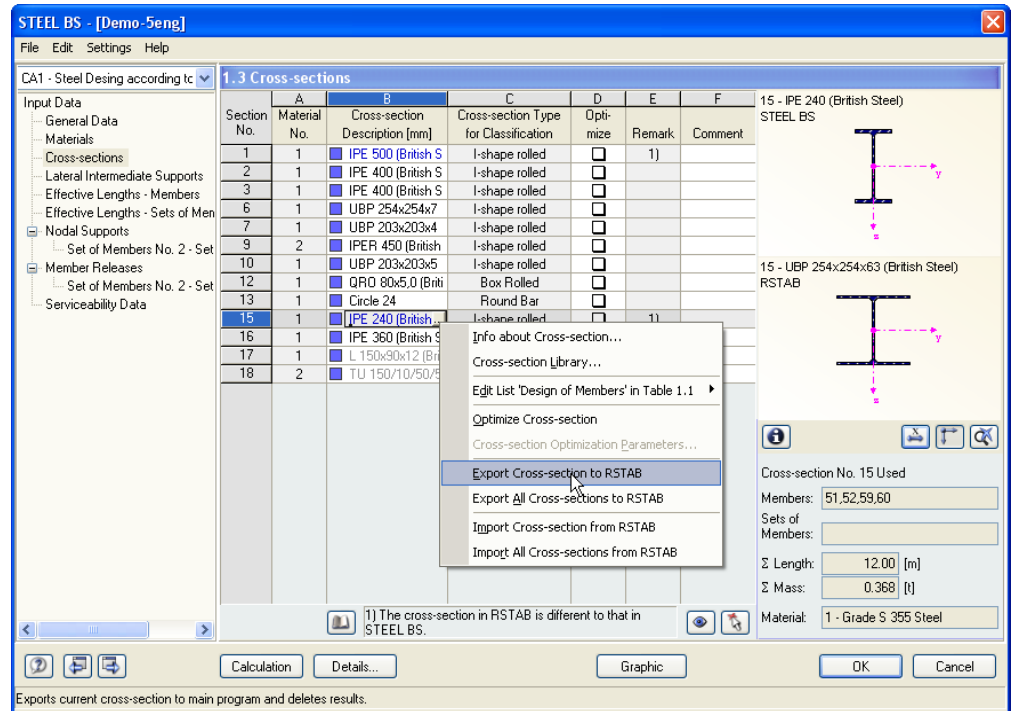

Figure 7.6: Context menu in table 1.3 *Cross-Sections*

Calculation

Before the changed cross-sections are transferred to RSTAB, a question appears because exporting also implies deleting the results. When you confirm the query and then start the [Calculation] in STEEL BS, the internal forces of RSTAB and the design ratios of STEEL BS are calculated in one calculation run.

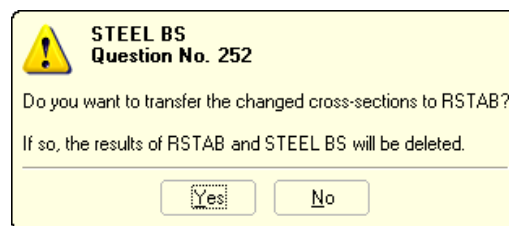

Figure 7.7: Question before transferring modified cross-sections to RSTAB

By using the menu functions described above, you can also import the original RSTAB cross-sections to STEEL BS. Please note that this option is only available in table 1.3 *Cross-sections*.



If you optimize a tapered member, the program modifies the member's start and end and interpolates the second moments of area for the intermediate locations linearly. As these moments are considered with the fourth power, the designs may be inaccurate if the depths of the start and end cross-section differ considerably. In this case, it is recommended to divide the taper into several single members whose start and end cross-sections have minor cross-section differences.

7.3 Import / Export of Materials

If you change a material in table 1.2 of STEEL BS, you can export it to RSTAB like cross-sections or also reload the original material from RSTAB to the module. The materials that have been modified in the module are marked in blue color.

You do not need to transfer the modified materials to RSTAB manually. Set table 1.2 *Materials*, and then

select **Export All Materials to RSTAB** on the **Edit** menu.

The context menu of table 1.2 also provides options to transfer modified materials to RSTAB.

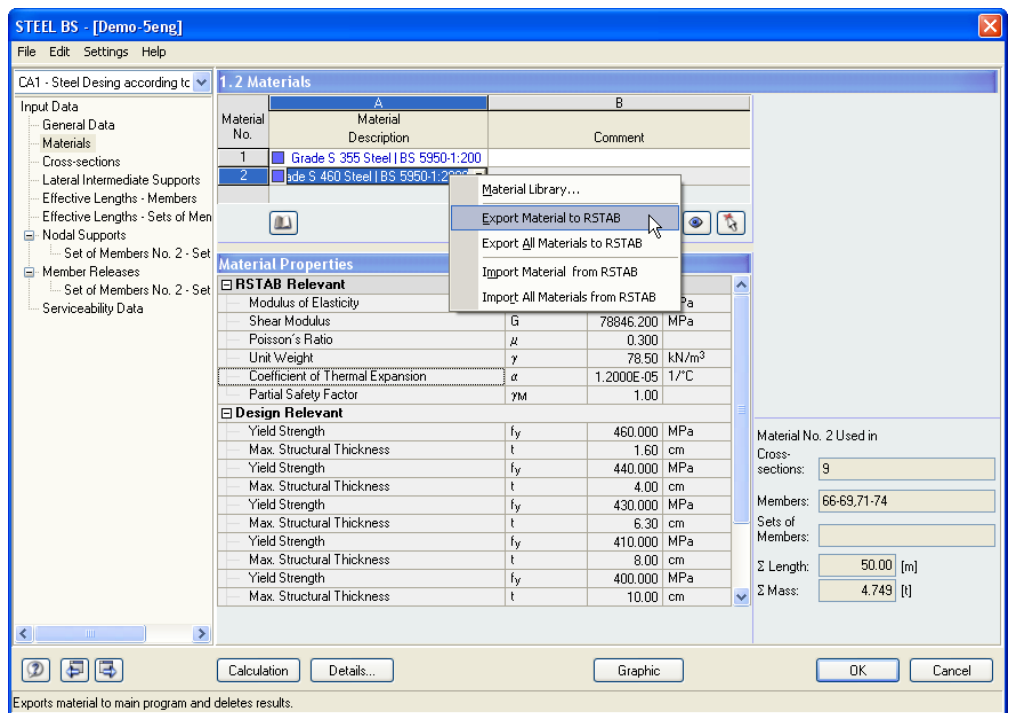

Figure 7.8: Context menu in table 1.2 *Materials*

Calculation

Before the changed materials are transferred to RSTAB, a question appears because exporting also implies deleting the results. When you confirm the query and then start the [Calculation] in STEEL BS, the internal forces of RSTAB and the design ratios of STEEL BS are calculated in one calculation run.

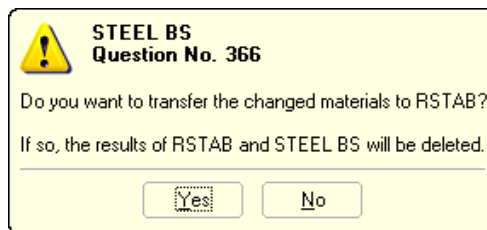

Figure 7.9: Question before transferring modified materials to RSTAB

7.4 Units and Decimal Places

The units and decimal places for RSTAB and all add-on modules are managed in one global dialog box. In the add-on module STEEL BS, you can use the menu to define the units. To open the corresponding dialog box,

select **Units and Decimal Places** on the **Settings** menu.

The program opens the following dialog box that you already know from RSTAB. The add-on module STEEL BS is preset.

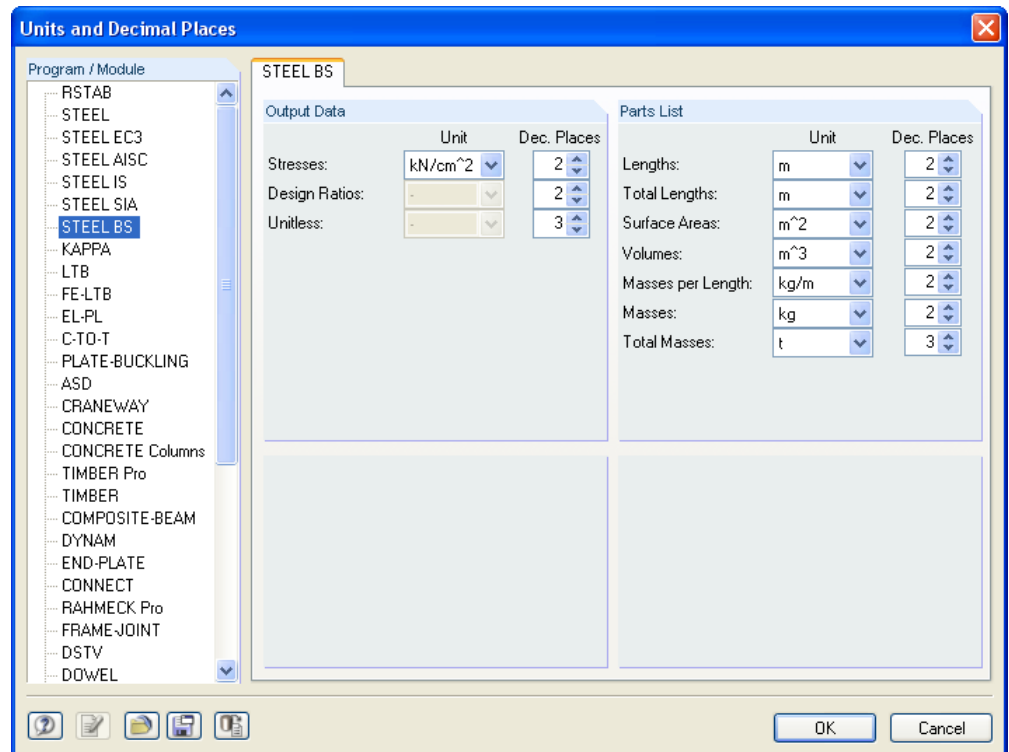

Figure 7.10: Units and Decimal Places dialog box



The settings can be saved as a user profile to reuse them in other structures. The corresponding functions are described in chapter 11.6.2 of the RSTAB manual.

7.5 Export Results

The design results can be transferred to other programs in various ways.

Clipboard

Select the relevant cells in the results table of STEEL BS and copy them to the clipboard via [Ctrl]+[C]. The contents can then be inserted via [Ctrl]+[V] to e.g. some word processing program. The headers of the table columns are not exported.

Printout Report

The STEEL BS data can be printed to the global printout report (see chapter 6.1, page 49) and then be exported via the printout report menu

File → **Export to RTF File or BauText**.

This function is described in chapter 10.1.11 of the RSTAB manual on page 239.

Excel / OpenOffice

STEEL BS enables you to directly export data to MS Excel or OpenOffice.org Calc. To open the corresponding dialog box,

select **Export Tables** on the **File** menu in the STEEL BS add-on module.

The following export dialog box appears.

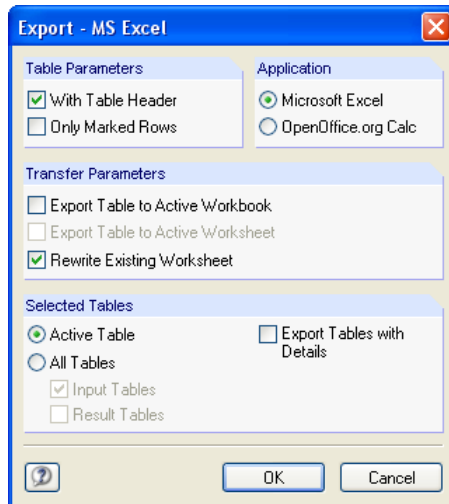

Figure 7.11: Export - MS Excel dialog box

When you have selected the relevant parameters, start the export by clicking [OK]. Excel or OpenOffice will be started automatically. It is not necessary to run the programs in the background.

	A	B	C	D	E	F
1	Member	Location	Load	Design		
2	No.	x [m]	Case	Ratio		Design according to Formula
3	1	Cross-section No. 1 - IPE 500 (British Steel)				
4		6,000	LC5	0,00 ≤ 1	100) No or Very Small Internal Forces	
5		0,000	LC6	0,00 ≤ 1	101) Cross-section Check - Tension acc. to 4.6	
6		0,000	LC1	0,02 ≤ 1	102) Cross-section Check - Compression acc. to 4.7.4	
7		5,400	LC3	0,02 ≤ 1	111) Cross-section Check - Bending about y-Axis for Low Shear acc. to 4.2.5.2 - Clas	
8		3,000	LC4	0,05 ≤ 1	116) Cross-section Check - Bending about z-Axis for Low Shear acc. to 4.2.5.2 - Clas	
9		0,000	LC2	0,01 ≤ 1	121) Cross-section Check - Shear Capacity - Load Parallel to the Web acc. to 4.2.3	
10		6,000	LC4	0,00 ≤ 1	123) Cross-section Check - Shear Capacity - Load Parallel to the Flange acc. to 4.2.3	
11		0,000	LC1	0,00 ≤ 1	126) Cross-section Check - Shear Buckling acc. to 4.4.5	
12		6,000	LC2	0,11 ≤ 1	181) Cross-section Check - Bending about y Axis, Shear and Axial Force acc. to 4.8.2	
13		3,000	LC6	0,06 ≤ 1	322) Lateral Torsional Buckling according to 4.3 and B.2 (I, H and Channel Cross-Section)	
14		0,000	LC1	0,08 ≤ 1	341) Stability Analysis - Buckling and Bending about y and z-Axis acc. to 4.8.3.3.1	
15		3,000	LC2	0,15 ≤ 1	351) Stability Analysis - Buckling about z-Axis and Bending about y and z-Axis with L	
16						
17	2	Cross-section No. 1 - IPE 500 (British Steel)				
18		6,000	LC5	0,00 ≤ 1	100) No or Very Small Internal Forces	
19		0,000	LC6	0,00 ≤ 1	101) Cross-section Check - Tension acc. to 4.6	
20		0,000	LC1	0,02 ≤ 1	102) Cross-section Check - Compression acc. to 4.7.4	
21		6,000	LC3	0,02 ≤ 1	111) Cross-section Check - Bending about y-Axis for Low Shear acc. to 4.2.5.2 - Clas	
22		3,000	LC4	0,05 ≤ 1	116) Cross-section Check - Bending about z-Axis for Low Shear acc. to 4.2.5.2 - Clas	
23		0,000	LC2	0,01 ≤ 1	121) Cross-section Check - Shear Capacity - Load Parallel to the Web acc. to 4.2.3	
24		6,000	LC4	0,00 ≤ 1	123) Cross-section Check - Shear Capacity - Load Parallel to the Flange acc. to 4.2.3	
25		0,000	LC1	0,00 ≤ 1	126) Cross-section Check - Shear Buckling acc. to 4.4.5	
26		6,000	LC2	0,11 ≤ 1	181) Cross-section Check - Bending about y Axis, Shear and Axial Force acc. to 4.8.2	

Figure 7.12: Results in Excel

8. Example

Column with Biaxial Bending

In the following example, we perform the governing stability designs of flexural buckling and lateral-torsional buckling for a column with biaxial bending. The calculation described below follows the *Load and Resistance Factor Design* provisions.

Design values

Structure and loads

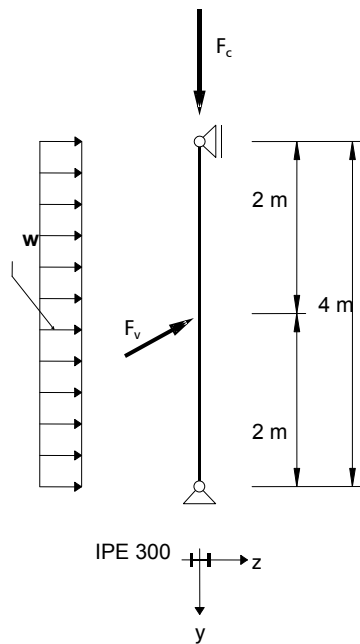

Design values of static loads:

$$F_c = 300 \text{ kN}$$

$$w = 5.0 \text{ kN/m}$$

$$F_v = 7.5 \text{ kN}$$

Cross-section: IPE 300

Material: Steel Grade S 275

Figure 8.1: Structure and design loads (γ -fold)

Internal forces according to linear static analysis

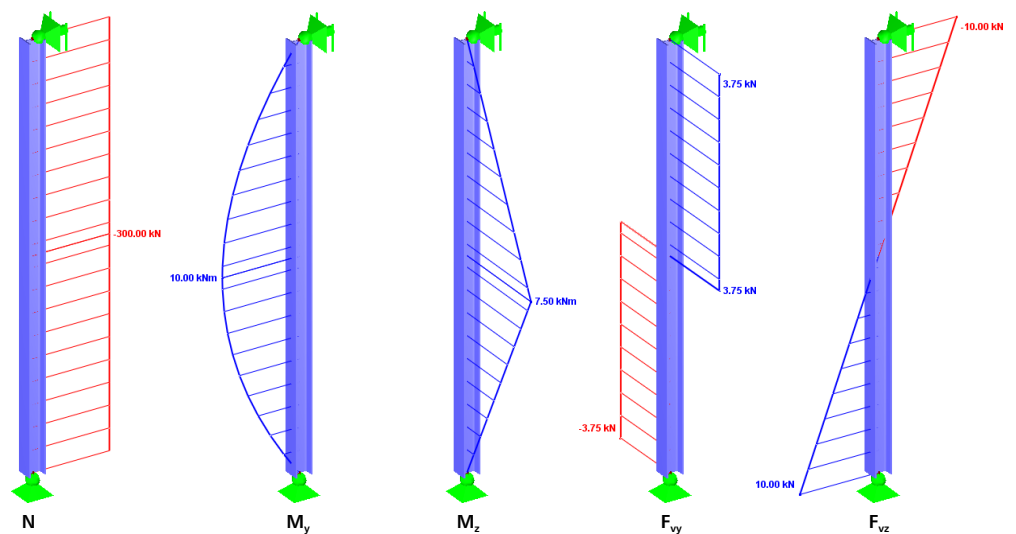

Figure 8.2: Internal Forces

Design location (decisive location x)

The design is performed by x-location, i.e. on defined locations x of the equivalent member. The decisive location is $x = 2.00$ m with the following internal forces of RSTAB:

$$F_c = -300.00 \text{ kN} \quad M_y = 10.00 \text{ kNm} \quad M_z = 7.50 \text{ kNm} \quad F_{vy} = 3.75 \text{ kN} \quad F_{vz} = 0.00 \text{ kN}$$

Cross-section properties - IPE 300

Cross-Section Properties	Symbol	Value	Unit
Gross area	A_g	53.80	cm ²
Moment of inertia about major axis	I_y	8356.00	cm ⁴
Moment of inertia about minor axis	I_z	604.00	cm ⁴
Radius of gyration about major axis	r_y	12.5	cm
Radius of gyration about minor axis	r_z	3.35	cm
Cross-section weight	w_t	42.2	kg/m
Torsion constant	J	19.90	cm ⁴
Warping constant	C_w	126000.00	cm ⁶
Elastic section modulus about major axis	Z_y	557.00	cm ³
Elastic section modulus about minor axis	Z_z	80.50	cm ³
Plastic section modulus about major axis	S_y	628.00	cm ³
Plastic section modulus about minor axis	S_z	125.22	cm ³
Strut curve for buckling about major axis	SC_y	a	
Strut curve for buckling about minor axis	SC_z	b	

Material properties – steel grade S275

Material Properties	Symbol	Value	Unit
Modulus of elasticity	E	205000	N/mm ²
Modulus of rigidity	G	78865	N/mm ²
Yield strength	p_y	275	N/mm ²

Classification of cross-section

$$\varepsilon = \sqrt{275 / p_y} = \sqrt{275 / 275} = 1.0$$

Classification of flange

$$b = 75 \text{ mm}$$

$$T = 10.7 \text{ mm}$$

$$\lambda_{f,1} = 8 \varepsilon = 8 \cdot 1.0 = 8$$

$$\lambda_{f,2} = 9 \varepsilon = 9 \cdot 1.0 = 9$$

$$\lambda_{f,3} = 13 \varepsilon = 13 \cdot 1.0 = 13$$

$$\frac{b}{T} = \frac{75}{10.7} = 7 \leq 8 = \lambda_{f,1}$$

Class of the flange is 1.

Classification of web

$$\sigma_{w,A} = -40.9 \text{ N/mm}^2$$

$$\sigma_{w,B} = -70.6 \text{ N/mm}^2$$

$$d = 278.6 \text{ mm}$$

$$t = 7.1 \text{ mm}$$

$$r_1 = \frac{F}{d \cdot t \cdot p_{yw}} = \frac{300 \cdot 10^3}{278.6 \cdot 7.1 \cdot 275} = 0.552$$

$$r_2 = \frac{F}{A} / (\rho_y) = \frac{300 \cdot 10^3}{54.9 \cdot 10^2} / (250 / 1.1) = 0.240$$

$$\lambda_{w,1} = \frac{84 \varepsilon}{1+r_1} = \frac{84 \cdot 1.0}{1+0.939} = 43.329$$

$$\lambda_{w,2} = \frac{105 \varepsilon}{1+1.5r_1} = \frac{105 \cdot 1.0}{1+1.5 \cdot 0.939} = 43.604$$

$$\lambda_{w,3} = \frac{126 \varepsilon}{1+2r_2} = \frac{126 \cdot 1.0}{1+2 \cdot 0.240} = 85.085$$

$$\frac{d}{t_{fw}} = \frac{206.8}{6.8} = 30.412 \leq 43.329 = \lambda_{w,1}$$

Class of the web is 1.

Class of the cross-section is 1.

Classification in STEEL BS

Cross-section Classification - Class 1					
Flange					
- Width	b	75.0	mm		Table 11
- Thickness	T	10.7	mm		Table 11
- Constant	ε_f	1.000			Table 11
- Maximal Ratio for Class 1	$\lambda_{f,1}$	9.000			Table 11
- Maximal Ratio for Class 2	$\lambda_{f,2}$	10.000			Table 11
- Maximal Ratio for Class 3	$\lambda_{f,3}$	15.000			Table 11
- Ratio	b/T	7.009		$\leq \lambda_{f,1}$	
- Class of Flange		1			Table 11
Web					
- Stress at Web Start	$\sigma_{w,A}$	-40.9	N/mm ²		
- Stress at Web End	$\sigma_{w,B}$	-70.6	N/mm ²		
- Depth	d	278.6	mm		Table 11
- Thickness	t	7.1	mm		Table 11
- Gross Area	A_g	5380	mm ²		
- Design Strength of the Web	p_{yw}	275.0	N/mm ²		
- Axial Compressive Force	Fc	-300.00	kN		
- Constant	ε_w	1.000			Table 11
- Stress Ratio	r_1	0.552			3.5.5
- Stress Ratio	r_2	0.203			3.5.5
- Maximal Ratio for Class 1	$\lambda_{w,1}$	51.563			Table 11
- Maximal Ratio for Class 2	$\lambda_{w,2}$	54.727			Table 11
- Maximal Ratio for Class 3	$\lambda_{w,3}$	85.376			Table 11
- Ratio	d/t	39.239		$\leq \lambda_{w,1}$	
- Class of Web		1			Table 11
- Class of Cross-Section		1			Table 11

Buckling about y-axis (major axis)

$$KL_y = 4.0 \text{ m}$$

$$t = 10.7 \text{ mm} < 40 \text{ mm} \Rightarrow \text{strut curve a}$$

Slenderness

$$\lambda_y = \frac{KL_y}{r_y} = \frac{4000}{125} = 32.1$$

Limit slenderness

$$\lambda_0 = 0.2 \sqrt{\left(\frac{\pi^2 E}{p_y}\right)} = 0.2 \sqrt{\left(\frac{3.1415^2 \cdot 205000}{275}\right)} = 17.155$$

Robertson constant for strut curve a: $a_y = 2.0$

Perry factor

$$\eta_y = \alpha(\lambda_y - \lambda_0) / 1000 = \frac{2.0(32.1 - 17.155)}{1000} = 0.03$$

Euler buckling stress

$$p_{Ey} = \frac{\pi^2 E}{\lambda_y^2} = \frac{3.1415^2 \cdot 205000}{32.1^2} = 1964.04 \text{ MPa}$$

Buckling factor

$$\phi_y = \frac{p_y + (\eta_y + 1)p_{Ey}}{2} = \frac{275 + (0.03 + 1) \cdot 1964.04}{2} = 1148.86 \text{ MPa}$$

Compressive strength

$$p_{cy} = \frac{p_y \cdot p_{Ey}}{\phi_y \cdot \sqrt{(\phi_y^2 - p_{Ey} \cdot p_y)}} = \frac{275 \cdot 1964.04}{1148.86 \cdot \sqrt{(1148.86^2 - 275 \cdot 1964.04)}} = 265.84 \text{ MPa}$$

Compression resistance

$$P_{cy} = p_{cy} \cdot A_g = 265.84 \cdot 5380 = 1430.08 \text{ kN}$$

Design Ratio

$$\eta = F_c / P_{cy} = 300.0 / 1430.08 = 0.21$$

- O.K.

Design in STEEL BS

Axial Compression	F_c	300.00	kN		
Design Strength	p_y	275.000	N/mm ²		
Modulus of Elasticity	E	205000.000	N/mm ²		
Nominal Effective Length	KL_y	4000.000	mm		
Radius of Gyration	r_y	124.626	mm		
Slenderness	λ_y	32.096			4.7.2
Limiting Slenderness	λ_0	17.155			C.2
Strut Curve	SC_y	a			Table 23
Robertson Constant	a_y	2.000			C.2
Perry Factor	η_y	0.030			C.2
Factor	ϕ_y	1148.860	N/mm ²		C.1
Euler Buckling Stress	p_{Ey}	1964.040	N/mm ²		C.1
Compressive Strength	p_{cy}	265.814	N/mm ²		C.1
Gross Area	A_g	5380.000	mm ²		
Compression Resistance	P_{cy}	1430.08	kN		4.7.4 / 4.7.5
Design Ratio	η	0.21		< 1.0	4.7.4

Buckling about z-axis (minor axis)

$$KL_z = 4.0 \text{ m}$$

$$t = 10.7 \text{ mm} < 40 \text{ mm} \Rightarrow \text{strut curve } b$$

Slenderness

$$\lambda_z = \frac{KL_z}{r_z} = \frac{4000}{33.5} = 119.4$$

Limit slenderness

$$\lambda_0 = 0.2 \sqrt{\left(\frac{\pi^2 E}{p_y} \right)} = 0.2 \sqrt{\left(\frac{3.1415^2 \cdot 205000}{275} \right)} = 17.155$$

Robertson constant for strut curve b: $a_z = 3.5$

Perry factor

$$\eta_z = \alpha(\lambda_z - \lambda_0) / 1000 = \frac{3.5 \cdot (119.4 - 17.155)}{1000} = 0.358$$

Euler buckling stress

$$p_{Ez} = \frac{\pi^2 E}{\lambda_z^2} = \frac{3.1415^2 \cdot 205000}{119.4^2} = 141.97 \text{ MPa}$$

Buckling factor

$$\phi_z = \frac{p_y + (\eta_z + 1)p_{Ez}}{2} = \frac{275 + (0.358 + 1) \cdot 141.97}{2} = 233.88 \text{ MPa}$$

Compressive strength

$$p_{cz} = \frac{p_y \cdot p_{Ez}}{\phi_z \cdot \sqrt{(\phi_z^2 - p_{Ez} \cdot p_y)}} = \frac{275 \cdot 141.97}{233.88 \cdot \sqrt{(233.88^2 - 275 \cdot 141.97)}} = 108.74 \text{ MPa}$$

Compression resistance

$$P_{cz} = p_{cz} \cdot A_g = 108.74 \cdot 5380 = 585.04 \text{ kN}$$

Design Ratio

$$\eta = F_c / P_{cz} = 300.0 / 585.04 = 0.51$$

- O.K., decisive

Design in STEEL BS

Axial Compression	F_c	300.00	kN		
Design Strength	p_y	275.000	N/mm ²		
Modulus of Elasticity	E	205000.000	N/mm ²		
Nominal Effective Length	KL_z	4000.000	mm		
Radius of Gyration	r_z	33.5	mm		
Slenderness	λ_z	119.4			4.7.2
Limiting Slenderness	λ_0	17.155			C.2
Strut Curve	SC_z	b			Table 23
Robertson Constant	a_z	3.500			C.2
Perry Factor	η_z	0.358			C.2
Factor	ϕ_z	233.88	N/mm ²		C.1
Euler Buckling Stress	p_{Ez}	141.97	N/mm ²		C.1
Compressive Strength	p_{cz}	108.74	N/mm ²		C.1
Gross Area	A_g	5380.000	mm ²		
Compression Resistance	P_{cz}	585.04	kN		4.7.4 / 4.7.5
Design Ratio	η	0.51		< 1.0	4.7.4

Lateral-torsional buckling

Effective length for lateral-torsional buckling

$$K_{L_{LT}} = 4.0 \text{ m}$$

Slenderness

$$\lambda = \frac{K_{L_{LT}}}{r_z} = \frac{4000}{33.5} = 119.38$$

Limit equivalent slenderness

$$\lambda_{L0} = 0.4 \sqrt{\left(\frac{\pi^2 E}{p_y}\right)} = 0.4 \sqrt{\left(\frac{3.1415^2 \cdot 205000}{275}\right)} = 34.31$$

Equivalent slenderness

$$\lambda_{LT} = u v \lambda \sqrt{\beta_w}$$

in which:

- distance between shear centers of the flanges $h_s' = 289.3 \text{ mm}$

$$x = 0.566 h_s' \sqrt{(A/J)} = 0.566 \cdot 289.3 \sqrt{(5380/19.9 \cdot 10^4)} = 26.92$$

$$v = \frac{1}{[1 + 0.05(\lambda/x)^2]^{0.25}} = \frac{1}{[1 + 0.05(119.38/26.92)^2]^{0.25}} = 0.84$$

$$\gamma = 1 - \frac{I_z}{I_y} = 1 - \frac{604 \cdot 10^4}{8356 \cdot 10^4} = 0.927$$

$$u = \left(\frac{4 S_y^2 \gamma}{A^2 h_s'^2}\right)^{0.25} = \left(\frac{4 \cdot 628 \cdot 10^3 \cdot 0.927}{5380^2 \cdot 289.3^2}\right)^{0.25} = 0.88$$

- for class 1: $\beta_w = 1$

finally

$$\lambda_{LT} = u v \lambda \sqrt{\beta_w} = 0.88 \cdot 0.84 \cdot 119.38 \cdot \sqrt{1} = 88.69$$

Check of slendernesses

$$\lambda_{LT} > \lambda_{L0} \rightarrow 88.69 > 34.31$$

- lateral-torsional buckling occurs

Robertson constant

- for LTB: $a_{LT} = 7.0$

Perry factor

$$\eta_{LT} = \alpha(\lambda_{LT} - \lambda_{L0})/1000 = \frac{8.0 \cdot (88.69 - 34.31)}{1000} = 0.381$$

Euler lateral-torsional buckling stress

$$p_{E,LT} = \frac{\pi^2 E}{\lambda_{LT}^2} = \frac{3.1415^2 \cdot 205000}{88.69^2} = 257.21 \text{ MPa}$$

Buckling factor

$$\phi_{LT} = \frac{p_y + (\eta_{LT} + 1)p_{E,LT}}{2} = \frac{275 + (0.381 + 1) \cdot 257.21}{2} = 315.06 \text{ MPa}$$

Bending strength

$$p_b = \frac{p_y \cdot p_{E,LT}}{\phi_{LT} \cdot \sqrt{(\phi_{LT}^2 - p_{E,LT} \cdot p_y)}} = \frac{275 \cdot 257.21}{315.06 \cdot \sqrt{(315.06^2 - 275 \cdot 257.21)}} = 146.15 \text{ MPa}$$

Buckling resistance moment

- for class 1 :

$$M_b = p_b \cdot S_y = 146.15 \cdot 628 \cdot 10^3 = 91.78 \text{ kNm}$$

Bending

About y-Axis (Major Axis)

Moment capacity

$$M_{by} = p_y \cdot Z_y = 275 \cdot 557 \cdot 10^3 = 153.175 \text{ kNm}$$

About z-Axis (Minor Axis)

Moment capacity

$$M_{bz} = p_z \cdot Z_z = 275 \cdot 80.5 \cdot 10^3 = 22.137 \text{ kNm}$$

Equivalent uniform moment factors and interaction factors

Bending about y-axis (major axis)

Equivalent uniform moment factor according to table 26

$$m_y = 0.2 + \frac{0.1M_2 + 0.6M_3 + 0.1M_4}{M_{\max}} = 0.2 + \frac{0.1 \cdot 7.5 + 0.6 \cdot 10 + 0.1 \cdot 7.5}{10} = 0.95$$

Bending about z-axis (minor axis)

Equivalent uniform moment factor according to table 26

$$m_z = 0.2 + \frac{0.1M_2 + 0.6M_3 + 0.1M_4}{M_{\max}} = 0.2 + \frac{0.1 \cdot 3.75 + 0.6 \cdot 7.5 + 0.1 \cdot 3.75}{7.5} = 0.9$$

Lateral-torsional buckling

Equivalent uniform moment factor according to table 18

$$m_{LT} = 0.2 + \frac{0.15M_2 + 0.5M_3 + 0.15M_4}{M_{\max}} = 0.2 + \frac{0.15 \cdot 7.5 + 0.5 \cdot 10 + 0.15 \cdot 7.5}{10} = 0.925$$

Member buckling resistance

The buckling resistance of a member may be verified by checking that the following relationships are both satisfied:

- Check according to 4.8.3.3.1a

P_c – is the smaller of P_{cy} and P_{cz} - for our case P_{cz} .

$$\frac{F_c}{P_c} + \frac{m_y M_y}{M_{by}} + \frac{m_z M_z}{M_{bz}} \leq 1$$

$$\frac{300}{585.04} + \frac{0.95 \cdot 10}{153.175} + \frac{0.9 \cdot 7.5}{22.137} \leq 1$$

$$0.51 + 0.07 + 0.34 \leq 1$$

$$0.88 \leq 1.0$$

- Satisfied

Design in STEEL BS – check no.341

Axial Compression	F_c	300.00	kN		
Design Strength	p_y	275.000	N/mm ²		
Gross Area	A_g	5380.000	mm ²		
Modulus of Elasticity	E	205000.000	N/mm ²		
Nominal Effective Length	KL_z	4000.000	mm		
Radius of Gyration	r_z	33.506	mm		
Slenderness	λ_z	119.380			4.7.2
Limiting Slenderness	λ_0	17.155			C.2
Strut Curve	SC_z	b			Table 23
Robertson Constant	a_z	3.500			C.2
Perry Factor	η_z	0.358			C.2
Factor	ϕ_z	233.881	N/mm ²		C.1
Euler Buckling Stress	p_{Ez}	141.967	N/mm ²		C.1
Compressive Strength	p_{cz}	108.744	N/mm ²		C.1
Compression Resistance	P_{cz}	585.04	kN		4.7.4 / 4.7.5
Compressive Design Ratio	η_{nz}	0.51			4.8.3.3
Maximum Moment	$M_{y,max}$	10.00	kNm		
Elastic Section Modulus	Z_y	557000.000	mm ³		
Moment Capacity	M_{cy}	153.18	kNm		4.2.5.2
Structure Type	Type	Non-sway			4.8.3.3.4
Equivalent Uniform Moment Factor	m_y	0.950			
Maximum Moment	$M_{z,max}$	7.50	kNm		
Elastic Section Modulus	Z_z	80500.000	mm ³		
Moment Capacity	M_{cz}	22.14	kNm		4.2.5.2
Structure Type	Type	Non-sway			4.8.3.3.4
Equivalent Uniform Moment Factor	m_z	0.900			
Bending Design Ratio	η_{mz}	0.07			4.8.3.3.1
Bending Design Ratio	η_{mz}	0.34			4.8.3.3.1
Design Ratio	η	0.88		< 1	4.8.3.3.1

- Check according to 4.8.3.3.1b

$$\frac{F_c}{P_{cz}} + \frac{m_{LT} M_{LT}}{M_b} + \frac{m_z M_z}{M_{bz}} \leq 1$$

$$\frac{300}{585.04} + \frac{0,925 \cdot 10}{91.78} + \frac{0,9 \cdot 7.5}{22.137} \leq 1$$

$$0.51 + 0.11 + 0.34 \leq 1$$

$$0.92 \leq 1.0$$

- Satisfied

Design in STEEL BS – check no.351

Axial Compression	F_c	300.00	kN		
Design Strength	p_y	275.000	N/mm ²		
Gross Area	A_g	5380.000	mm ²		
Modulus of Elasticity	E	205000.000	N/mm ²		
Nominal Effective Length	KL_z	4000.000	mm		
Radius of Gyration	r_z	33.506	mm		
Slenderness	λ_z	119.380			4.7.2
Limiting Slenderness	λ_0	17.155			C.2
Strut Curve	SC_z	b			Table 23
Robertson Constant	a_z	3.500			C.2
Perry Factor	η_z	0.358			C.2
Factor	ϕ_z	233.881	N/mm ²		C.1
Euler Buckling Stress	p_{Ez}	141.967	N/mm ²		C.1
Compressive Strength	p_{cz}	108.744	N/mm ²		C.1
Compression Resistance	P_{cz}	585.04	kN		4.7.4 / 4.7.5
Compressive Design Ratio	η	0.51			4.8.3.3
Maximum Moment	$M_{LT,y,max}$	10.00	kNm		
Effective Length	L_E	4000.000	mm		4.3.5
Slenderness	λ	119.380			4.3.6.7
Limiting Slenderness	λ_{L0}	34.310			B.2.2
Equivalent Slenderness	λ_{LT}	88.692		$> \lambda_{L0}$	
Robertson Constant	a_{LT}	7.000			B.2.1
Perry Factor	η_{LT}	0.381			B.2.1
Factor	ϕ_{LT}	315.062	N/mm ²		B.2.1
Euler Buckling Stress	$p_{E,LT}$	257.211	N/mm ²		B.2.1
Bending Strength	p_b	146.151	N/mm ²		4.3.6.5
Plastic Section Modulus	S_y	628000.000	mm ³		
Elastic Section Modulus	Z_y	557000.000	mm ³		
Buckling Resistance Moment	$M_{b,y}$	91.78	kNm		4.3.6.4
Moment Factor	m_{LT}	0.925			4.3.6.6
LTB Design Ratio	$\eta_{m,LT}$	0.11			4.8.3.3.1
Maximum Moment	$M_{z,max}$	7.50	kNm		
Elastic Section Modulus	Z_z	80500.000	mm ³		
Moment Capacity	M_{cz}	22.14	kNm		4.2.5.2
Structure Type	Type	Non-sway			4.8.3.3.4
Equivalent Uniform Moment Factor	m_z	0.900			
Bending Design Ratio	η_{mz}	0.34			4.8.3.3.1
Design Ratio	η	0.92		< 1	4.8.3.3.1

A Literature

- [1] Structural use of steelwork in buildings – Part1: Code of practice for design – Rolled and Welded sections, BS 5950-1:2000, BS 05-2001
- [2] Eurocode 3: Design of steel structures – Part 1-1: General rules and rules for buildings, 2005
- [3] Rules for Member Stability in EN 1993-1-1, ECCS Technical Committee 8 – Stability
- [4] Eurocode 3: Design of steel structures – Part 1-4: Supplementary rules for Stainless steels, 2006
- [5] Die neuen Stabilitätsnachweise im Stahlbau nach Eurocode 3, NAUMES J., STROHMANN I., UNGERMANN D., SEDLACEK G., Stahlbau 77 (2008) Heft 10, Ernst & Sohn

B Index

B	
Background graphics	42
Buckling about axis	23
Buckling length coefficient	22, 23
Buckling possible	23
Buttons	41
C	
Calculation	29
Camber	28
Cantilever beam	20, 28
Charakteristic	10
Classification	19
Close STEEL BS	8
Color bars	41
Color spectrum	47
Colored ratios	47
Column buckling	20, 21
Control panel	47
Coordinate system	16
Cross-section description	16
Cross-section library	16, 17
Cross-section optimization	53
Cross-section parts (c/t)	18
Cross-sections	16
D	
Decimal places	14, 56
Deflection	10
Deformation	30
Design	9
Design by cross-section	34
Design by load case	33
Design case	43, 51, 52
Design combination	10
Design ratio	34
Design situation	34
Details	29
Display hidden result diagram	47
Display navigator	43, 47
E	
Effective length	21, 22
Effective Slenderness	39
Elastic critical moment	30
Equivalent uniform moment factor	24
Evaluation of results	41
Excel	57
Export cross-section	54
Export material	55
Export materials	55
Export results	56
F	
Filter members	48
Filter results	47
Forked support	20
Frequent	10
G	
General data	8
Governing internal forces	37
Graph of results	46
Graphic	42
I	
Installation	5
Internal forces	53
L	
Lateral intermediate supports	20
Lateral-torsional buckling	11, 20, 24
Length	21, 39
Limit load	30
Limit values	10
List of members	28
Load application	30
Load case	9, 10
Load combination	10
Location x	34, 36, 37
M	
Material description	14
Material library	15
Material properties	14
Materials	14
Maximum design ratio	19
Member diagrams	45

Member release 27

Members 9

N

National annex 11

Naumes 11

Navigator 8

Nodal support 25

Non-sway 30

O

OpenOffice 57

Optimization 19, 30, 53

P

Panel 7, 44, 47

Parameterized cross-section 53

Part 39

Partial view 47

Parts list 39

Print 49

Print STEEL BS graphics 49

Printout report 49, 50, 56

Q

Quasi-permanent 10

R

Reference length 28

Relatively 20

Release 27

Remark 19

Rendering ratios 47

Result diagram 46, 49

Result values 43

Results representation 43

Results tables 33

RSBUCK 22

RSTAB graphic 49

RSTAB work window 42

S

Safety factors 11

Scaling 45

Serviceability design 28

Serviceability limit state 10, 30

Set of members 9, 24, 25, 27, 35, 38, 40

Shifted member ends 30

Slenderness 38

Stability analysis 11

Stainless steel 13

Start calculation 31

Start STEEL BS 6

STEEL BS design cases 51

Stress point 17, 18

Structure type 30

Sum 40

Support 25

Surface area 40

Sway 30

Switch tables 8

T

Tables 8

Taper 54

Tapered member 17, 34

U

Ultimate limit state 8

Undeformed system 30

Unit weight 40

Units 14, 56

User profile 56

V

View mode 41, 42

Visualization 42

Volume 40

W

Weight 40